

\$5.00

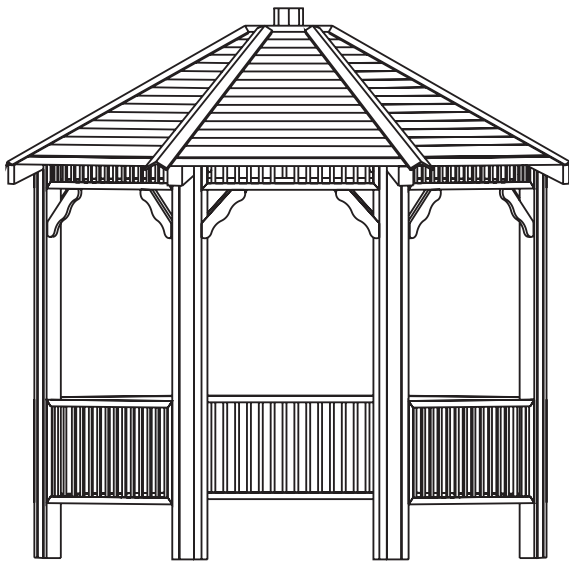

# 2004 Owner's Manual

## LATTICE GAZEBO



**Octagon**

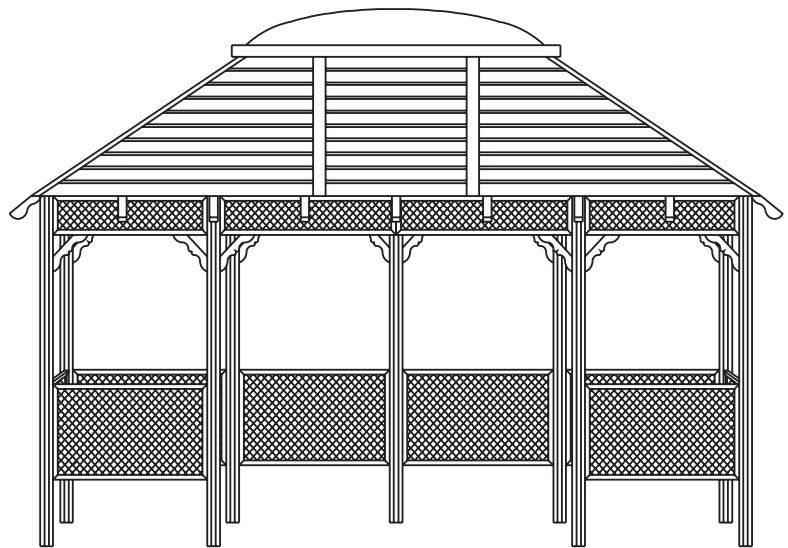

**Rectangle**

Duplication without written consent is strictly prohibited.

This Owner's Manual is for gazebos manufactured after January 1, 2004

Due to continuous improvement programs, all models, operation, and/or specifications are subject to change without prior notice.

LTR17000775

\$5.00



# 2004 Owner's Manual

## LATTICE GAZEBO

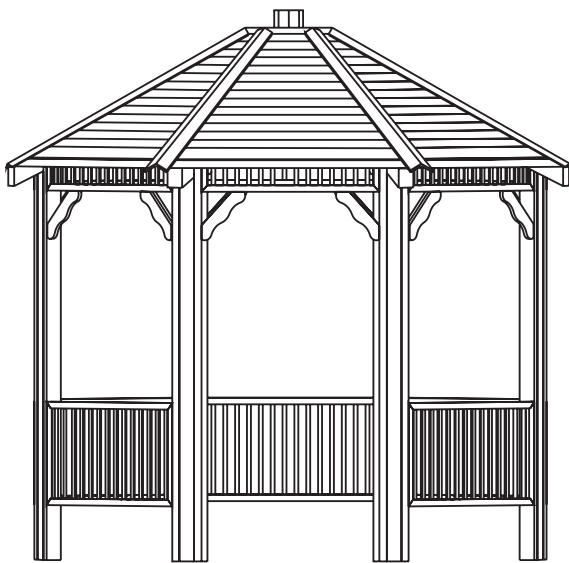

Octagon

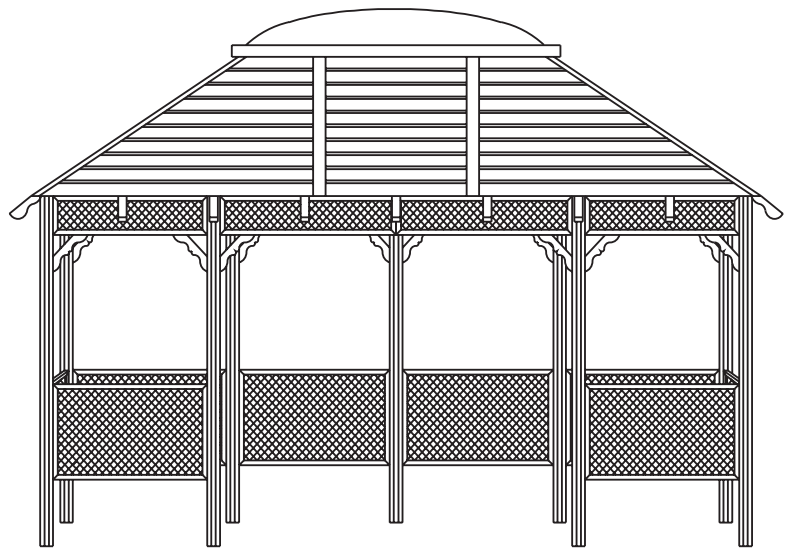

Rectangle

Duplication without written consent is strictly prohibited.  
This Owner's Manual is for gazebos manufactured after January 1, 2004  
Due to continuous improvement programs, all models, operation, and/or specifications are subject to change without prior notice.  
LTR17000775

# Table of Contents

Benefits of Owning a Gazebo .....	2
Safety Instructions .....	3
Contact Information.....	4
Warranty Information .....	4
Set-up and Delivery .....	5
Assembly .....	9
Cleaning, Maintenance and Troubleshooting .....	15
Appendix .....	16
Accessories .....	17
Parts List.....	18
Notes.....	34

### BENEFITS OF OWNING A GAZEBO

Owning a gazebo allows you to have a wonderful place to unwind after a long day of work. It offers a place for you to socialize with family and friends. It offers great cover in the event that you purchase a bar-b-que and/or spa. Owning a gazebo can add character to your patio and/or yard. You can use a gazebo for whatever best suits your needs.

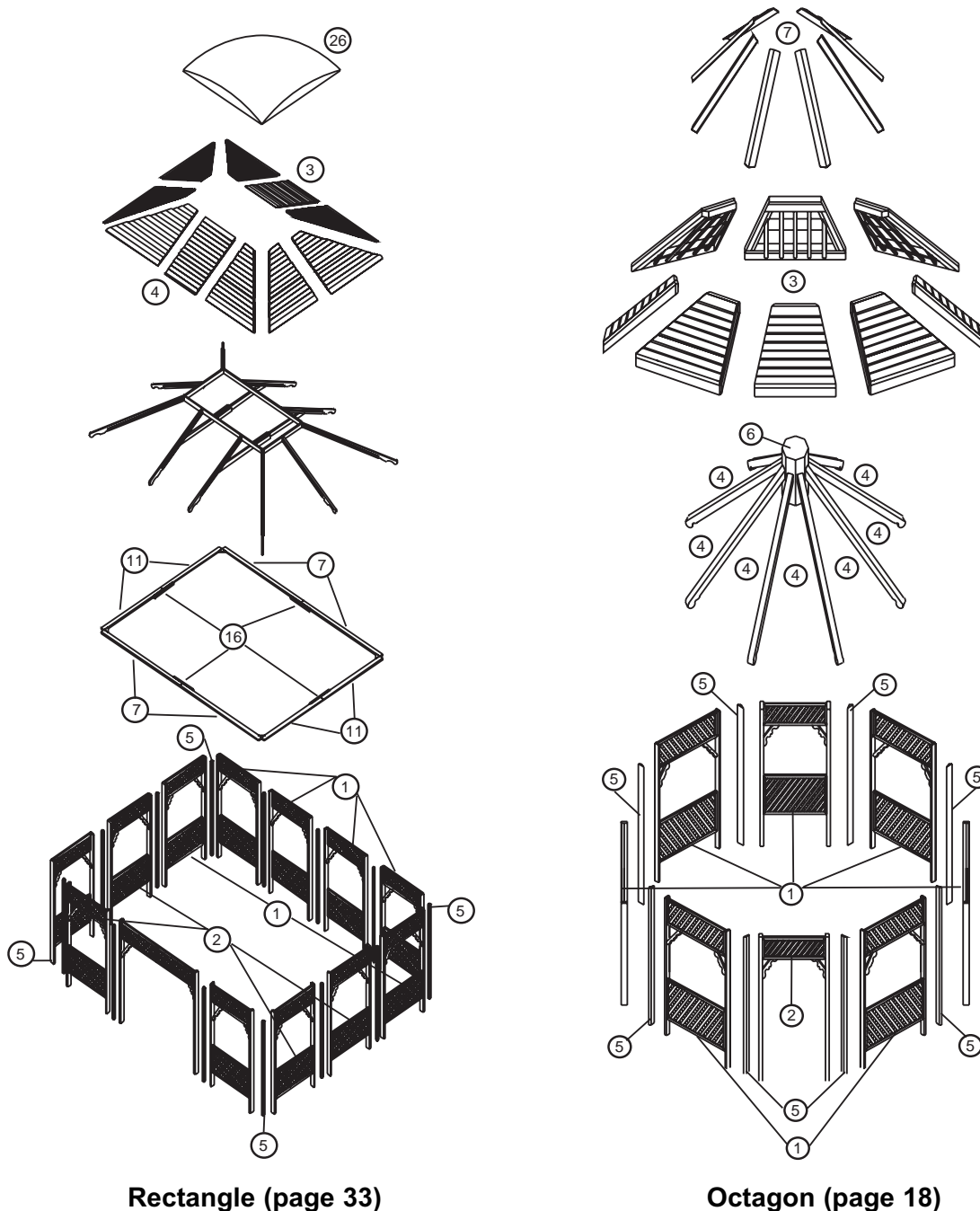

Rectangle (page 33)

Octagon (page 18)

Figure 1. Lattice Gazebo

**NOTE:** The numbers in Figure 1 are located in the back of this manual, in the “Parts List” section.

## **SAFETY INSTRUCTIONS**

### **Carefully read and follow all safety instructions.**

1. When installing and assembling your gazebo, it is recommended that 2 or more people be involved.
2. Do not use the unit during an electrical storm, as there is a remote chance of getting struck by lightning.
3. Do not climb on top of the gazebo. While the gazebo is made out of high-quality wood and is extremely durable, the gazebo is not meant to be used as a jungle gym. Thus, falling off of the gazebo while climbing on it can result in serious injury, possibly even death.
4. Do not attempt any repair without consulting the manufacturer first. Unauthorized repair attempts will void the manufacturer's warranty.

**Save this information.**

## CONTACT INFORMATION

For customer service, please contact your authorized dealer immediately. If you need additional information and/or assistance, please contact:

C.A.I. Customer Service Department  
1462 East Ninth Street  
Pomona, CA 91766  
Toll Free: 1-800-CAL-SPAS  
Fax: 1-909-629-3890

## WARRANTY INFORMATION

See your Cal Spas Creative Wood Designs dealer for a copy of the applicable warranty, details and any questions you may have regarding the warranty coverage on your gazebo.

### Warranty Limitations

The Limited Warranty is void if the gazebo has been subject to negligence, alteration, misuse, abuse, repairs by non- C.A.I. authorized representatives, acts of God and any other cases beyond the control of C.A.I. Examples of common acts invalidating this warranty include but are not limited to:

Use of the gazebo in a non-residential application.

Scratches caused by normal use.

Damage caused by extreme weather conditions. (hot, cold, etc.)

Damage caused by dirt, sand, and/or water damage.

Damage caused by continuous operation of the gazebo with either known or unknown problems.

Damage caused by direct sunlight.

Damage caused as a result of failure to follow the assembly instructions as defined in this Owner's Manual.

This Limited Warranty applies only to gazebos normally used for personal, family, or household purposes.

This Limited Warranty specifically excludes commercial gazebos.

### Warranty Exclusions

C.A.I. warrants the gazebo from defects in material and workmanship for a period of 90 days from the original date of purchase.

**REMINDER: PLEASE DO NOT FORGET TO REGISTER YOUR NEW PRODUCT AT WWW.CALSPAS.COM.**

## DELIVERY AND SET-UP

Please make a record of the following. It will be valuable if service is required.

Gazebo Model: \_\_\_\_\_

Gazebo Serial Number: \_\_\_\_\_

Date Purchased: \_\_\_\_\_

Date Installed: \_\_\_\_\_

Gazebo Dealer's Phone Number: \_\_\_\_\_

Gazebo Dealer's Address: \_\_\_\_\_

Most cities and counties require permits for exterior construction and electrical circuits. In addition, some communities have codes requiring residential barriers such as fencing and/or self-closing gates on property to prevent unsupervised access to the property by children under the age of 5. Your dealer can provide information on which permits may be required and how to obtain them prior to the delivery of your equipment.

## PLANNING THE BEST LOCATION FOR YOUR GAZEBO

Here are some of the things that you will need to consider when determining where to locate your new gazebo.

### How Will You Use Your Gazebo?

How you intend to use your gazebo will help you determine where you should position it. For example, will you use your gazebo for recreational purposes? If your gazebo is mainly used for family functions, be sure to leave plenty of room around it for activity. In any case dealing in how it is to be used, you'll probably want to create a specific mood around it.

### Consider Your Privacy

In a cold- weather climate, bare trees won't provide much privacy. Think of your gazebos surroundings during all seasons to determine your best privacy options. Consider the view of your neighbors as well, when you plan the location of your gazebo.

### Provide A View With Your Gazebo

Think about the direction you will be facing when sitting in your gazebo. Do you have a special landscaped area in your yard that you find enjoyable? Perhaps there is an area that catches a soothing breeze during the day and lovely sunset in the evening. Consider these things when you plan your location.

## PREPARING A GOOD FOUNDATION

Your gazebo needs a solid and level foundation. The area that it sits on must be able to support the weight of the gazebo and the occupants who use it. If the foundation is inadequate, it may shift or settle after the gazebo is in place, causing stress that could alter the structures figure and possibly split the wooden joints.

**NOTE:** Damage caused by inadequate or improper foundation support is not covered by the warranty. It is the responsibility of the gazebo owner to provide a proper foundation for the gazebo.

Place the gazebo on an elevated foundation (preferably a 3” concrete slab).

- \* If you are installing your gazebo on an elevated wood deck or other structure, it is highly recommended that you consult a structural engineer or contractor to ensure the structure will support the weight.
- \* It is strongly recommended that a qualified, licensed contractor prepare the foundation for your gazebo.

## Your Cal Spas Creative Wood Designs Retailer Can Help You With Foundations And More

Your retailer has a wealth of information and experience about how to get the most out of your gazebo. Your gazebo retailer also has a full line of accessories that are engineered to compliment your gazebo.

**NOTE:** It is strongly advised that you have a licensed professional install the foundation for your new gazebo. It is imperative that the foundation is level, as any damage that occurs due to an uneven foundation is not covered by the warranty.

## Size Specifications

<b><u>Model</u></b>	<b><u>Length</u></b>	<b><u>Width</u></b>
Frontier Gazebo	8'	8'
	10'	8'
	12'	8'
Cottage Gazebo	8'	8'
Cabana Gazebo	7'	7'
	7.5'	7.5'
	8'	8'
Northeast Gazebo	7.5'	7.5'
	8'	8'
Lattice Wall Gazebo	7'	7'
	7.5'	7.5'
	8'	8'
	12'	8'
	16'	8'
	10'	10'
	12'	10'
	16'	10'
	12'	12'



<u>Model</u>	<u>Length</u>	<u>Width</u>
<b>Lattice Wall Gazebo (cont.)</b>	12'	12'
	16'	12'
	10' (Octagon)	10'
	12' (Octagon)	12'
Plexi Wall Gazebo	7'	7'
	7.5'	7.5'
	8'	8'
	12'	8'
	16'	8'
	10'	10'
	12'	10'
	12'	12'
	16'	12'
	10' (Octagon)	10'
	12' (Octagon)	12'
	15' (Octagon)	15'
18' (Octagon)	18'	
Luxury Wall Gazebo	7'	7'
	7.5'	7.5'
	8'	8'
	12'	8'
	16'	8'
	10'	10'
	12'	10'
	16'	10'
	12'	12'
	16'	12'
Savannah Wall Gazebo	12'	8'
	10'	10'
	12'	10'
	16'	10'
	12'	12'
	16'	12'
	10' (Octagon)	10'
	12' (Octagon)	12'
15' (Octagon)	15'	
18' (Octagon)	18'	
Timberline Gazebo	12'	8'
	10'	10'
	12'	10'
	12'	12'
	16'	12'

<b><u>Model</u></b>	<b><u>Length</u></b>	<b><u>Width</u></b>
Lighthouse Gazebo	10'	10'
	12'	10'
	12'	12'
	16'	12'
Plantation Gazebo	10'	10'
	12'	10'
	12'	12'
	16'	12'
Chalet Gazebo	12'(Octagon)	12'
	14'(Octagon)	14'
	16'(Octagon)	16'
Victorian Gazebo	12'(Octagon)	12'
	14' (Octagon)	14'
	16' (Octagon)	16'

**NOTE:** The gazebo above that is listed in bold lettering is the gazebo that you purchased.

**NOTE:** For all gazebos, regardless of model, it is recommended that the foundation (concrete slab, railroad ties or pre-cast stepping stones) extend beyond the dimension of the gazebo. For example, if the gazebo you purchased is 12'x12', you will want your foundation to be 12.5'x12.5'. The reason for this is because it will be easier to maintain the area around the gazebo (mowing the lawn, edging, etc.) without damaging or scarring the gazebo. Also, in doing this, you will eliminate any potential problems, foundation-wise, in the future.

**NOTE:** This Owner's Manual applies to the various sizes that are included in the Lattice Gazebo line (7'x7', 7.5'x7.5', 8'x8', 12'x8', 16'x8', 10'x10', 12'x10', 16'x10', 12'x12', and 16'x12'; Octagon - 10'x10' and 12'x12'). While the sizes will vary from gazebo to gazebo, the assembly instructions will be the same, unless otherwise noted.

**Tools and Materials**

- |                           |                                      |
|---------------------------|--------------------------------------|
| Utility Knife             | 25' Tape Measure                     |
| Cordless Drill            | 100' Extension Cord                  |
| 1/8" Pilot Hole Drill Bit | 1/2" Ratchet and Impact Drill        |
| Electric Drill            | 9/16" Socket                         |
| Phillips-Head Drill Tips  | 1/2" Carbide Drill Bit (Masonry Bit) |
| Slotted-Head Drill Tips   | Sandpaper (Various Grades)           |
| Redwood Stain             | Wood Putty                           |
| Gray Wash Stain           | Rags                                 |

# Assembly Instructions

The following sections are broken in to two parts: Octagon and Rectangle. These sections will tell you how to assembly your gazebo. If you have any questions, problems with material and/or parts, please contact your local retailer.

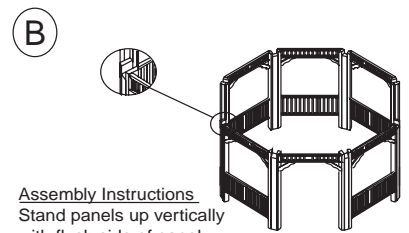
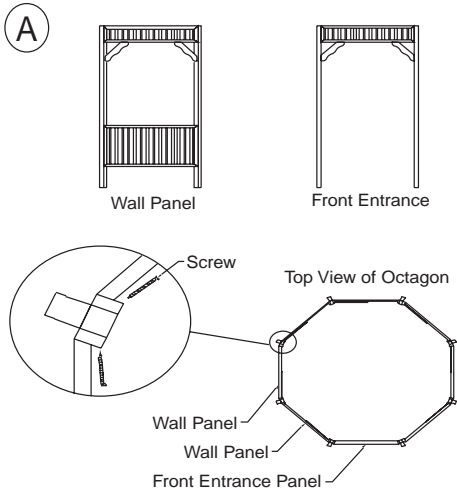

**Assembly Instructions**  
Stand panels up vertically with flush side of panel facing inward. Then fit panels together as shown.

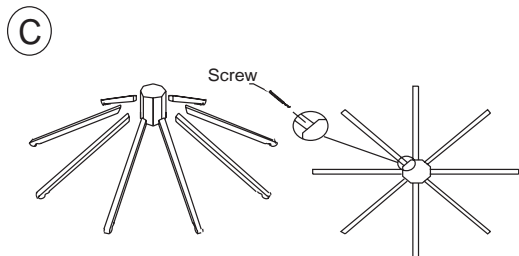
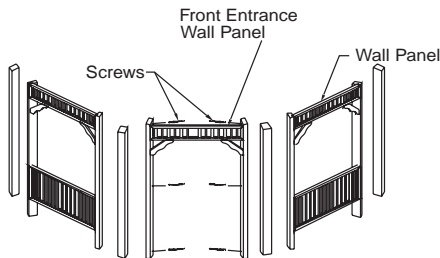

## Wall Panel Assembly - Octagon

**NOTE:** All wall panels are pre-assembled at the factory before being shipped.

**NOTE:** Please follow the written steps in conjunction with the figures that are shown.

**NOTE:** The smooth side of each wall panel should be facing the inside of the gazebo.

**NOTE:** Check the parts list that came with your gazebo and make sure that all the parts are present.

1. Stand panels up vertically with the flush side of the panel facing inward (fit panels together as shown in **Figure 2A**).
2. Drill holes in all 2"x4" boards. The holes have already been drilled for the wall panels. Line up the holes and mark the 2"x4" and drill accordingly.
3. Insert the provided 7"x5/16" threaded rod and washer into the pre-drilled holes and tighten with the nut (**Figure 2B**).
4. To build the roof frame assembly, attach each roof support (8 total) to the 8-sided roof center support using the provided drywall screws (**Figure 2C**).

**Figure 2. Wall Panel Assembly**

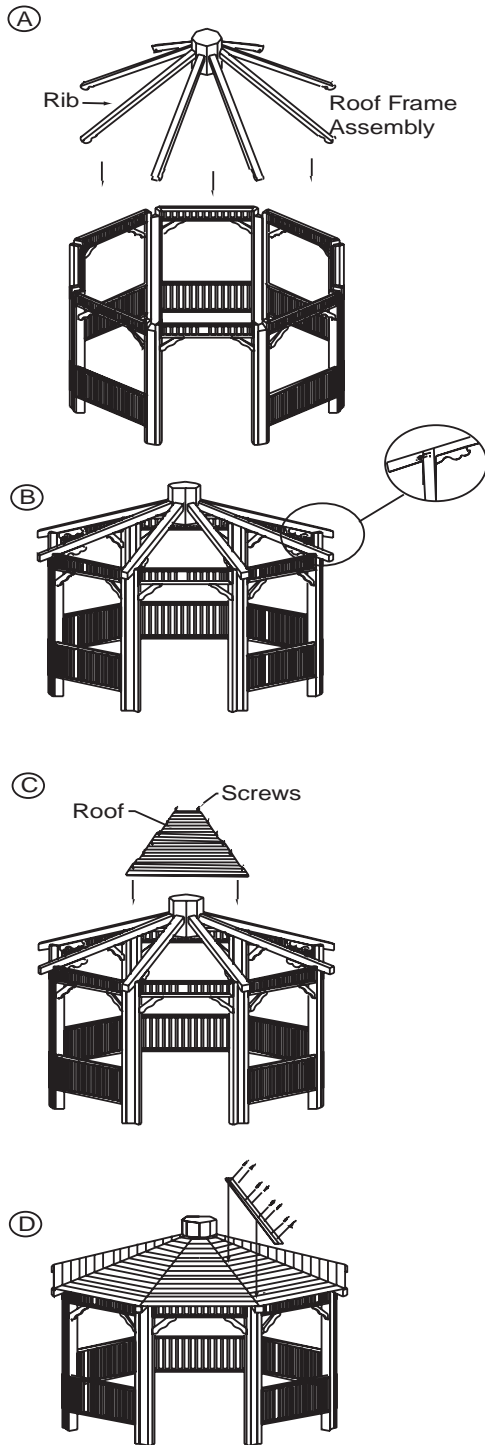

### COMPOSITION ROOF ASSEMBLY

**NOTE:** Check the parts list that came with your gazebo and make sure that all the parts are present. Also, please follow the written steps in conjunction with the figures that are shown.

1. Having already assembled the wall panels, and now the roof frame, pick up the roof assembly and place it on top of the wall panel assembly (**Figure 3A**).
2. The top of each wall panel support has a slot (8 total). Place each “rib” of the roof frame into each one of these slots (**Figure 3B**).
3. Using the provided hardware, insert a 5/16”x18”x3 1/2” bolt into the pre-drilled hole that is located on the slotted end of the wall panel support and the “rib” section of the roof frame.
4. Repeat this step until the roof frame is securely attached to the wall panel assembly.
5. Take one 4-sided section of shingled roof and attach it to the corresponding location on top of the roof frame (**Figure 3C**).
6. Take each ridge cap and attach using drywall screws (**Figure 3D**).

**Figure 3.** Composition Roof Assembly

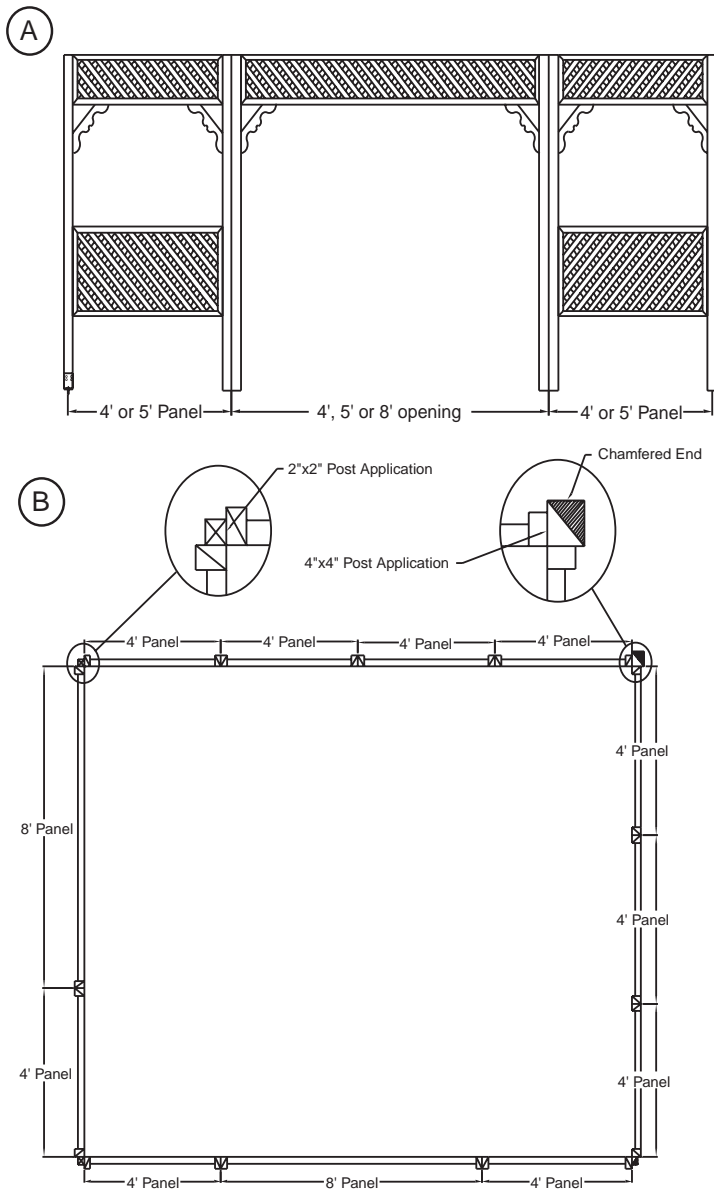

### Wall Panel Assembly - Rectangle

- NOTE:** All wall panels are pre-assembled at the factory before being shipped.
- NOTE:** Please follow the written steps in conjunction with the figures that are shown.
- NOTE:** The smooth side of each wall panel should be facing the inside of the gazebo.
- NOTE:** Check the parts list that came with your gazebo and make sure that all the parts are present.

1. Stand two panels up side by side. Attach the panels together using 5 drywall screws (**Figure 4A**).
2. Each corner should be secured following the sample in **Figure 4B (inset)**.
4. Repeat this step until all the panels are attached. **Figure 4B** will show you the wall panel layout.

**NOTE:** The rounded corners attach to the wall panels the same way, with 5 drywall screws. The owner must use care when securing the wall panel and rounded corner together, as any damage incurred during assembly is not covered by the warranty.

**NOTE:** Use care when attaching the sides and corners. Be sure that the windows do not come in contact with the mounting screws.

**Figure 4.** Composition Roof Assembly

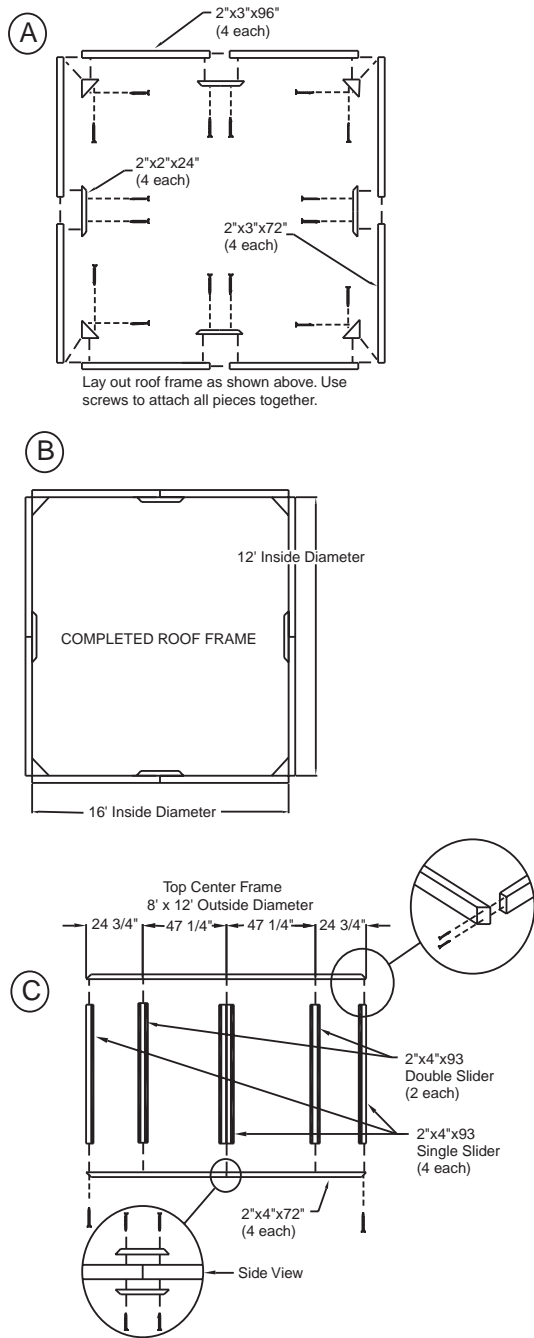

### Roof Frame Assembly

When assembling the roof frame, it is recommended that you lay everything out and assemble it on a flat surface. It is also recommended that there be another person available when installing the roof frame on to the gazebo walls.

**NOTE:** Check the parts list that came with your gazebo and make sure that all the parts are present. Also, please follow the written steps in conjunction with the figures that are shown.

1. Take four 2"x4"x96" pieces of wood and four 2"x4"x72" pieces of wood and lay them out on the ground (**Figure 5A**), in effect making a square.
2. Use the provided drywall screws to attach all the pieces together. When complete, the outside diameter should measure 12'x16' (**Figure 5B**).
3. Place corner stabilizer (4 each) and attach in each corner (**Figure 5A**) using drywall screws. Take four 2"x2"x24" pieces of wood and attach to each center point on the side of the roof frame.
4. Attach each corner together with the provided screws, making sure to keep the 45° corners pointing outward (**Figure 5C - inset**). This is the top center frame.
5. Take four single-slider rafters and two double-slider rafters attach them to the middle of each side of the top center frame assembly (**Figure 5C**). Use the toe-in method (see **inset**) and follow the specified measurements (**Figure 5C**).

**Figure 5.** Roof Frame Assembly

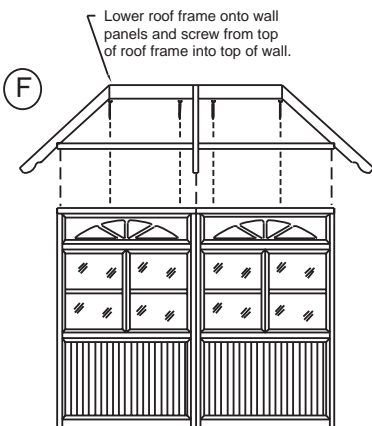
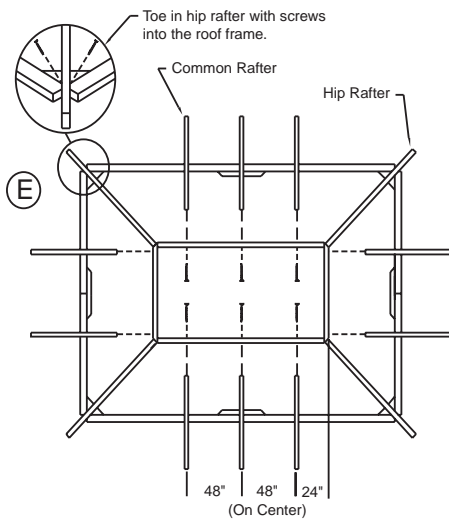
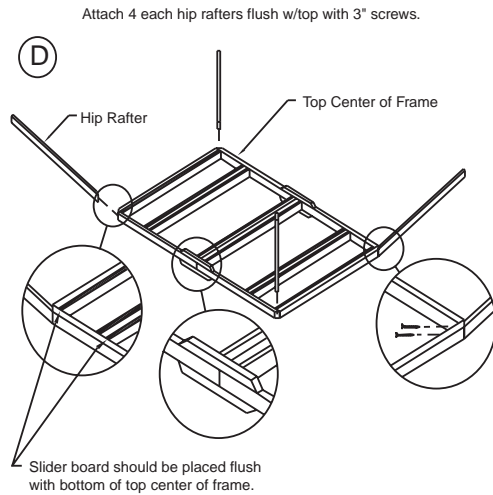

6. Take the hip rafters (4 each) and attach them to each corner of the top center frame. Make sure that the 45° corner matches the 45° end on the hip rafters (**Figure 5D**).
7. Take 4 common rafters and attach them to the middle of each side of the top center frame assembly (**Figure 5D**). Use the toe-in method (**see inset**).
8. With the common rafters now installed, attach the the remaining jack rafters using the toe-in method. Make sure that each jack rafter is spaced evenly apart. This will ensure sufficient anchoring points for the roof panels.
9. **Figure 5E** shows what the roof frame will look like when it is completed.

**NOTE:** It is recommended that you have an assistant for the following step.

10. Place the assembled roof section on top of the wall panel assembly. Anchor the roof section by using drywall screws (**Figure 5F**).

**Figure 5.** Composition Roof Assembly

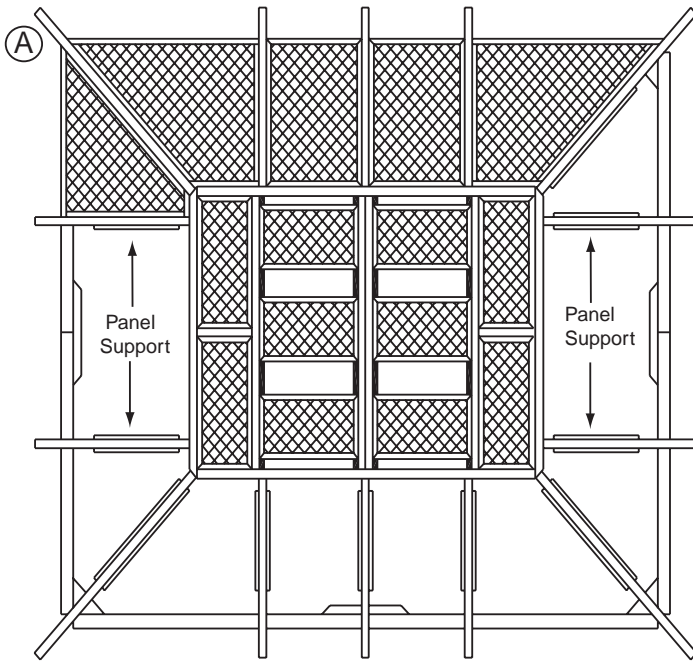

### Roof Panel Installation

**NOTE:** It is strongly recommended that you use a ladder for the final steps of the gazebo assembly.

1. Place each roof panel in place (with the edge resting on the panel supports) and mount using drywall screws (**Figure 6A**).

**NOTE:** If your model gazebo has a dome roof, please refer to Step 3.

2. Using the provided hardware, mount the dome bracket (**Figure 6B**).
3. Use 2 1/2" drywall screws to mount all ridge caps.
4. Set the roof assembly onto the wall panel assembly and attach using drywall screws.

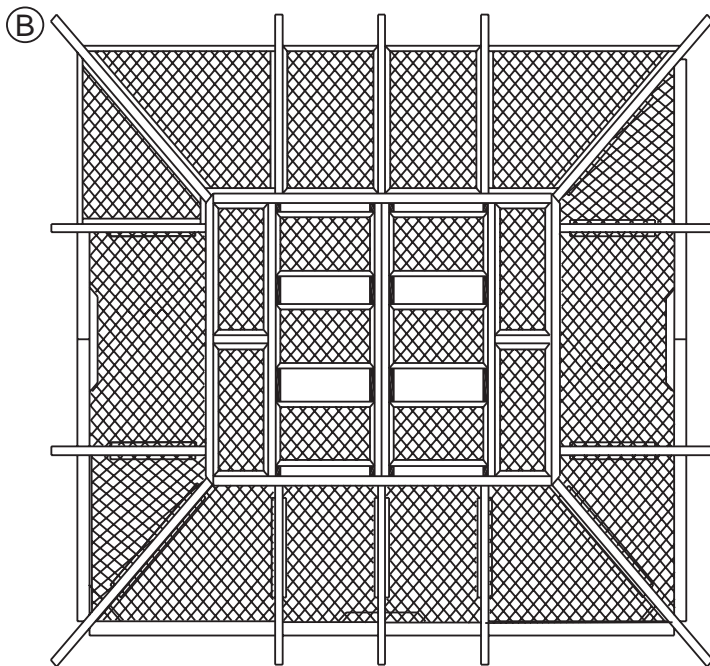

**Figure 6.** Roof Panel Assembly



# CLEANING, MAINTENANCE AND TROUBLESHOOTING

## Cleaning

Your gazebo was designed with low cleaning and maintenance in mind. We recommend that the gazebo be cleaned at least twice a month (or more, if needed). When cleaning your gazebo, cleaning solvents are not recommended. Using a sponge and water will be fine. For ground-in dirt and grime, please refer to the following section.

## Maintenance

Maintaining your gazebo will be an easy task. We recommend that every six months you should do an inspection of the wood on your gazebo. Take note of any deformities in the wood (i.e. cracking, peeling, dirt, grime, etc.). It is recommended that you spot sand these areas with 120-grit sandpaper. When complete, wipe these areas clean with a damp rag.

When dry, you must apply a coat of stain to the sanded area. Wipe the stained area clean and reapply until the sanded area matches the rest of the gazebo.

**NOTE:** An 8oz. can of stain will be supplied with each gazebo. To replace the can of stain, please contact your local Cal Enclosures dealer.

**NOTE:** On models that have plexi-glass windows, the use of a cheese cloth and warm water should be used. These windows are made of plexi-glass and do not hold up well under the abrasive conditions that many commercial cleaners generate.

## TROUBLESHOOTING PROCEDURES

**Q: Why will the windows on the gazebo not stay open/closed?**

**A:** This is most likely due to the fact that your foundation is not level. Foundations will most likely have a 1/4" pitch for drainage reasons. To rectify this problem, the gazebo must be shimmed on the low side. Using a standard level, shim the low side so that the gazebo is level.

**Q: Why won't the roof panels not sit correctly on the roof frame?**

**A:** Check the top plate on the top center frame and make sure it is level and installed correctly.

**Q: My roof and wall panels are lining up correctly and there are small gaps in the joint seams. Why is this?**

**A:** The main support post is not "plumb" (meaning vertically level). You must go back and make sure that the main support post is plumb. Also, you must make sure that each of your main support beams is "square" in relation to the main support post (meaning that there is a 90° angle when the main support post and the main support beam intersect).

## **APPENDIX**

The items that will be covered in this section will consist of the following:

Accessories

Part Numbers

Notes

In order for your retailer to expedite your order, for parts and accessories, it is recommended that you have the information that you attained in the Set-Up and Delivery section. Customer Service will want all this information for warranty purposes.

## ACCESSORIES

The following is a list of all the accessories that you can use with your Cal Spa Creative Wood Designs Gazebo. If you wish to order an accessory, feel free to contact your dealer with the desired part name and part number, or visit [www.calspas.com](http://www.calspas.com).

<b>Description</b>	<b>Size</b>	<b>Wood</b>	<b>Part Number</b>	
			<b>Cal Stone</b>	<b>Deluxe Stone</b>
Bar Top	11'	WOOD289	WOOD289CS	WOOD289DS
	80'	WOOD288	WOOD288CS	WOOD288DS
	75'	WOOD287	WOOD287CS	WOOD287DS
Round Corner		WOOD199	WOOD199CS	WOOD199DS
Storage Bench	11'	WOOD905	WOOD905CS	WOOD905DS
	80'	WOOD902	WOOD902CS	WOOD902DS
	75'	WOOD901	WOOD901CS	WOOD901DS
Crescent S/B		WOOD900	WOOD900CS	WOOD900DS
Bar Corbel		WOO270405060		
Bench Leg		WOO27405020		
Bar Stool		WOOD127	WOOD127CS	WOOD127DS
Surround Step	11'	WOOD296		
	80'	WOOD297		
	75'	WOOD298		
Crescent Step		WOOD214		
30' Step		WOOD107		
30" Storage Step w/Box		WOOD133		
5' Step		WOOD109		
5' Step Storage w/Box		WOOD134		
30" Step w/Handrail		WOOD107-2		
Round Planter		WOOD101		
Square Planter		WOOD100		
Crown Planter		WOOD189		
Octagon Planter		WOOD148		
Crescent Planter		WOOD168		
Bench	11'	WOOD923	WOOD923CS	WOOD923DS
	80'	WOOD922	WOOD922CS	WOOD922DS
	75'	WOOD921	WOOD921CS	WOOD921DS
Crescent Bench		WOOD920	WOOD920CS	WOOD920DS
Privacy Panel		WOOD183		
30" Step (3 tier)	30"	WOOD108		
30" Step (3 Tier with Handrail)	30"	WOOD108-2		
Towel/Wine Glass Rack	4'	WOOD113		
Towel/Wine Glass Rack	5'	WOOD113-5		
Wine Glass Hanger		WOOD114		
Towel Tree		WOOD169		
Kidzone Playhouse		KDZ100		

## PARTS LIST

### 10' - 10' Lattice Wall Solid Roof - Octagon

Description	Part Number	Quantity
4' Lattice Wall Panel (Lo)	WOO27107660	7
4' Lattice Door Panel	WOO27105820	1
2"x52"x10' Solid Octagon Roof Panel	WOO27206340	8
81" Rafter (10' Octagon)	WOO27208180	8
2"x2"x82 1/2" Corner Connector	WOO27106840	8
10' Octagon Top Center	WOO27211480	1
73" Crown Molding	WOO27211500	8
8x2 1/2" Screw SQ Drive Drywall	HAR13201150	80
8x3" SQ Drive Drywall	HAR13201140	15

### 12' - 12' Lattice Wall Solid Roof - Octagon

Item Number	Description	Part Number	Quantity
1	5' Lattice Wall Panel (Low)	WOO27105860	7
2	5' Lattice Door Panel	WOO27105840	1
3	2"x64"x12' Solid Octagon Roof Panel	WOO27206980	8
4	98" Rafter (12' Octagon)	WOO27208160	8
5	2"x2"x82 1/2" Corner Connector	WOO27106840	8
6	10' Octagon Top Center	WOO27211480	1
7	2"x4"x90" Crown Molding	WOO27208200	8
8	8x2 1/2" Screw SQ Drive Drywall	HAR13201150	80
9	8x3" SQ Drive Drywall	HAR13201140	15

### 7' - 7' Lattice Wall Solid Roof

Description	Part Number	Quantity
2"x2"x84" Corner Connector	WOO27106120	4
2"x3"x84" Legs for Wall Panel	WOO27102680	8
2"x4"x6 1/2" M2 Corner Stabilizer	WOO27200600	4
2"x4"x79" Top of Wall Panel	WOO27106960	4
2"x3"x82" Header Boards	WOO27107760	4
2"x4"x16" Corbel Mitered 2	WOO27200060	8
22 1/2"x79" Lattice Panel	WOO27106560	3
8x3" Screw SQ Drive Dry wall	HAR13201140	20
8x2 1/2" Screw SQ Drive Dry wall	HAR13201150	100
40"x40" Dome w/Frame	WOO27211620	1
Dome Bracket	HAR13800020	4
8 x1" Dome Bracket Screw	HAR13200200	20
8 x1" Metal Roof Screw	HAR13200200	50

**7' - 7' Lattice Wall Solid Roof**

<b>Description</b>	<b>Part Number</b>	<b>Quantity</b>
2"x2"x84" Corner Connector	WOO27106120	4
2"x3"x84" Legs for Wall Panel	WOO27102680	8
2"x4"x6 1/2" M2 Corner Stabilizer	WOO27200600	4
2"x4"x79" Top of Wall Panel	WOO27106960	4
2"x3"x82" Header Boards	WOO27107760	4
2"x4"x16" Corbel Mitered 2	WOO27200060	8
22 1/2"x79" Lattice Panel	WOO27106560	3
8x3" Screw SQ Drive Dry wall	HAR13201140	20
8x2 1/2" Screw SQ Drive Dry wall	HAR13201150	100
40"x40" Dome w/Frame	WOO27211620	1
Dome Bracket	HAR13800020	4
8x1" Dome Bracket Screw	HAR13200200	20
2"x4"x53" Hip Rafter (STD), No Slider	WOO27200500	4
22 1/2"x79" Lattice Panel	WOO27106560	3
47 1/2" Crown Molding Metal	HAR13900180	4
2"x4"x32 1/2" Mitered 1	WOO27208800	4
#1 XL700 Metal Roof Panel	WOO27200680	4
8x1 1/2" TEK w/ Washer	HAR13200223	15
8 x1" Metal Roof Screw	HAR13200200	50

**7.5' - 7.5' Lattice Wall Solid Roof**

<b>Description</b>	<b>Part Number</b>	<b>Quantity</b>
2"x2"x84" Corner Connector	WOO27106120	4
2"x3"x84" Legs for Wall Panel	WOO27102680	8
2"x4"x6 1/2" M2 Corner Stabilizer	WOO27200600	4
2"x4"x85 Top of Wall	WOO27106980	4
2"x4"x16" Corbels Mitered 2	WOO27200060	8
2"x4"x38 1/2" M1	WOO27208780	4
8x3" Screw SQ Drive Dry wall	HAR13201140	20
8x2 1/2" Screw SQ Drive Dry wall	HAR13201150	100
46"x46" Dome w/ Frame	WOO27211680	1
2"x3"x88" Header Boards	WOO27107740	4
2"x4"x53" Hip Rafter Standard	WOO27207740	4
2"x4"x49" Crown Molding	WOO27208320	4
22 1/2"x85" Lattice Panel	WOO27106420	3
39"x101" XL 750 Solid Roof Panel	WOO27205140	4
Dome Bracket	HAR13800020	4
8x1" Dome Bracket Screw	HAR13200200	20

**7.5' - 7.5' Lattice Wall Metal Roof**

<b>Description</b>	<b>Part Number</b>	<b>Quantity</b>
2"x2"x84" Corner Connector	WOO27106120	4
2"x3"x84" Legs for Wall Panel	WOO27102680	8
2"x4"x6 1/2" M2 Corner Stabilizer	WOO27200600	4
2"x4"x85 Top of Wall	WOO27106980	4
2"x4"x16" Corbels Mitered 2	WOO27200060	8
2"x4"x38 1/2" M1	WOO27208780	4
8x3" Screw SQ Drive Dry wall	HAR13201140	20
8x2 1/2" Screw SQ Drive Dry wall	HAR13201150	100
46"x46" Dome w/ Frame	WOO27211680	1
2"x3"x88" Header Boards	WOO27302600	4
2"x4"x53" Hip Rafter (STD) No Slider	WOO27200500	4
2"x3"x41" Common Rafter	WOO27200560	8
22 1/2"x85" Lattice Panel	WOO27106420	3
47 1/2" Crown Molding Metal	HAR13900180	4
#2 XL750 Metal Roof Panel	WOO27200700	4
8 x 1 1/2" TEK Screw w/Washer	HAR13200223	15

**8' - 8' Lattice Wall Metal Roof**

<b>Description</b>	<b>Part Number</b>	<b>Quantity</b>
2"x2"x84" Corner Connector	WOO27106120	4
2"x3"x84" Legs for Wall Panel	WOO27102680	8
2"x4"x6 1/2" M2 Corner Stabilizer	WOO27200600	4
2"x4"x93" Top of Wall	WOO27107000	4
2"x3"x96" Header Board	WOO27107720	4
2"x4"x53" Hip Rafter (STD) No Slider	WOO27200500	4
2"x3"x41" Common Rafter	WOO27200560	12
2"x4"x16" Corbels Mitered 2	WOO27200060	8
22 1/2"x93" Lattice Panel	WOO27106480	3
47 1/2" Crown Molding Metal	HAR13900180	4
36" Crown Molding Metal	HAR13900160	4
2"x4"x46 1/2" Moon Roof Assembly	WOO27208720	4
#4 Metal Roof Panel (L)	WOO27200720	4
#4 Metal Roof Panel (R)	WOO27200740	4
8 x 3" Screw Drive Drywall	HAR13201140	20
8 x 2 1/2" Screw Drive Drywall	HAR13201150	100
54"x54" Dome w/ Frame	WOO27211740	1
Dome Bracket	HAR13800020	4
8 x 1 1/2" TEK w/ Washer	HAR13200223	30
8 x 1" Metal Roof Screw	HAR13200200	80

**8' - 8' Lattice Wall Solid Roof**

<b>Description</b>	<b>Part Number</b>	<b>Quantity</b>
2"x2"x84" Corner Connector	WOO27106120	4
2"x3"x84" Legs for Wall Panel	WOO27102680	8
2"x4"x6 1/2" M2 Corner Stabilizer	WOO27200600	4
2"x3"x96" Header Boards	WOO27107720	4
2"x4"x93" Top of Wall	WOO27107000	4
2"x4"x53" Hip Rafter Standard	WOO27207740	4
2"x4"x49" Crown Molding	WOO27208320	4
2"x4"x16" Corbels Mitered 2	WOO27200060	8
2"x2"x4 1/2" Roof Panel Support	WOO27106700	4
22 1/2"x93" Lattice Panel	WOO27106480	3
47"x109" XL800 Solid Roof Panel	WOO27204700	4
2"x4"x46 1/2" Moon Roof Frame M1	WOO27208700	4
8 x 3" Screw SQ Drive Drywall	HAR13201140	20
8 x 2 1.2" Screw SQ Drive Drywall	HAR13201150	100
54"x54" Dome w/ Frame	WOO27211740	1
Dome Bracket	HAR13800020	4
8 x 1" Dome Bracket Screw	HAR13200200	20

**8' - 12' Lattice Wall Metal Roof**

<b>Description</b>	<b>Part Number</b>	<b>Quantity</b>
4' Lattice Wall Panel (High)	WOO27103220	5
4' Lattice Wall Panel (Low)	WOO27107660	2
4' Lattice Door Panel	WOO27200680	1
2"x2"x24" M2	WOO27106900	2
#4 Metal Roof Panel (R)	WOO27200740	4
#4 Metal Roof Panel (L)	WOO27200720	4
#6 Center Metal Panel	WOO27200800	2
2"x2"x84" Corner Connector	WOO27106120	4
2"x3"x96" Header Boards	WOO27107720	2
2"x3"x72" Header Boards	WOO27107700	4
2"x4"x94 1/2" M1	WOO27208460	2
2"x3"x72" M2 Cross Ties	WOO27209140	2
2"x4"x46 1/2" B & BTR M1	WOO27208720	2
2"x4"x6 1/2" M2 Corner Stabilizer	WOO27200600	4
40 1/2" Common Rafter, No Slider	WOO27200520	16
2"x4"x53" Hip Rafter (STD) No Slider	WOO27200500	4
9 1/2"x93" Lattice Panel Assembly	WOO27106880	1
2"x3"x84" Legs for Wall	WOO27102680	2
2"x4"x16" Wall Corbels	WOO27200060	2
22 1/2"x93" Lattice Panel	WOO27106480	1
36" Center Molding Metal	HAR13900160	6
47 1/2" Corner Molding Metal	HAR13900180	4
8 x 3" Screw SQ Drive Drywall	HAR13201140	25
8 x 2 1/2" Screw SQ Drive Drywall	HAR13201150	125
Coil Strap	HAR13900070	8
6 x 1 1/4" Phil Oval Screw 18.8	HAR13200240	60
8 x 1" Metal Roof Screw	HAR13200200	100

**8' - 12' Lattice Wall Metal Roof (Continued)**

<b>Description</b>	<b>Part Number</b>	<b>Quantity</b>
8 x 1 1/2" TEK w/ Washer	HAR13200223	35
Dome Bracket	HAR13800020	6
54"x102" Dome w/Frame	WOO27211800	1

**8' - 12' Lattice Wall Solid Roof**

<b>Description</b>	<b>Part Number</b>	<b>Quantity</b>
4' Lattice Wall Panel (High)	WOO27103220	5
4' Lattice Wall Panel (Low)	WOO27107660	2
4' Lattice Door Panel	WOO27105820	1
2"x2"x24" M2	WOO27106900	2
36"x53"x4' Solid Roof Panel (R)	WOO27201380	4
36"x53"x4' Solid Roof Panel (L)	WOO27201400	4
36"x46 1/2" Center Roof Panel Solid	WOO27211020	2
2"x2"x84" Corner Connector	WOO27106120	4
2"x3"x96" Header Boards	WOO27107720	2
2"x3"x72" Header Boards	WOO27107700	4
2"x4"x94 1/2" M1	WOO27208460	2
2"x4"x72" M2 Ross Ties	WOO27209140	2
2"x4"x46 1/2" B & BTR M1	WOO27208720	2
2"x4"x6 1/2" Corner Stabilizer M2	WOO27200600	4
40 1/2" Common Rafter	WOO27208100	6
2"x4"x53" HIP Rafter (STD)	WOO27207740	4
9 1/2"x93" Lattice Panel Assembly	WOO27106880	1
22 1/2"x93" Lattice Panel	WOO27106480	1
2"x3"x84" Legs for Wall	WOO27102680	2
2"x4"x16" Wall Corbels	WOO27200060	2
2"x4"x49" Crown Molding	WOO27208320	4
2"x4"x37" Crown Molding	WOO27208340	6
Coil Strap	HAR13900070	8
#6 x 6 1/4" Phil Oval 18.8	HAR13200240	60
8 x 3" Screw SQ Drive Drywall	HAR13201140	25
8 x 2 1/2" Screw SQ Drive Drywall	HAR13201150	125
54"x102" Dome w/ Frame	WOO27211800	1
Dome Bracket	HAR13800020	6
8 x 1" Dome Bracket Screw	HAR13200200	25



**8' - 16' Lattice Wall Metal Roof**

<b>Description</b>	<b>Part Number</b>	<b>Quantity</b>
4' Lattice Wall Panel (High)	WOO27103220	6
4' Lattice Wall Panel (Low)	WOO27107660	3
4' Lattice Door Panel	WOO27103760	1
#4 Metal Roof Panel (R)	WOO27200740	4
#4 Metal Roof Panel (L)	WOO27200720	4
Center Metal Panel	WOO27200800	4
2"x2"x84" Corner Connector	WOO27106120	4
2"x4"x72" M1	WOO27208600	4
2"x4"x96" Top of Wall Header Boards	WOO27107720	6
2"x4"x45" Center Support	WOO27210580	4
40 1/2" Common Rafter, No Slider	WOO27200520	20
2"x4"x72" Hip Rafter (STD) No Slider	WOO27200500	4
2"x4"x72 M2 Cross Ties	WOO27209140	3
2"x4"x6 1/2" Corner Stabilizer M2	WOO27200600	4
36" Molding Center Metal	HAR13900160	8
47 1/2" Molding Corner Metals	HAR13900180	4
Coil Strap	HAR13900070	6
8 x 3" Screw SQ Drive Drywall	HAR13201140	25
8 x 2 1/2" Screw SQ Drive Drywall	HAR13201150	125
2"x2"x24" M2	WOO27106900	2
Dome Bracket	HAR13800020	6
Dome Bracket Screw	HAR13200200	30
54"x75" Plexi Dome	WOO27212140	2
2"x4"x75"	WOO27107500	4
2"x4"x51"	WOO27213880	3
1"x3"x54"	WOO27502420	1
9 1/2"x93" Lattice Panel Assembly	WOO27106880	1
2"x3"x84" Legs for Wall	WOO27102680	2
2"x4"x16" Wall Corbels	WOO27200060	2
22 1/2"x93" Lattice Panel	WOO27106480	1
8 x 1" Metal Roof Screw	HAR13200200	100
8 x 1 1/2" Molding Screw	HAR13200050	35

**8' - 16' Lattice Wall Solid Roof**

<b>Description</b>	<b>Part Number</b>	<b>Quantity</b>
4' Lattice Wall Panel (High)	WOO27103220	6
4' Lattice Wall Panel (Low)	WOO27107660	3
4' Lattice Door Panel	WOO27103760	1
36"x53"x4' Solid Roof Panel (R)	WOO27201380	4
36"x53"x4' Solid Roof Panel (L)	WOO27201400	4
36"x46 1.2" Center Roof Panel, Solid	WOO27211020	4
2"x2"x84" Corner Connector	WOO27106120	4
2"x4"x72" M1	WOO27208600	4
2"x3"x96" Top of Wall Header Boards	WOO27107720	6
2"x4"x45" Center Support	WOO27210580	4
2"x4"x53" Hip Rafter (STD) No Slider	WOO27207740	4
40 1/2" Common Rafter, No Slider	WOO27208100	8
2"x4"x72 M2 Cross Ties	WOO27209140	3
2"x4"x6 1/2" Corner Stabilizer M2	WOO27200600	4
2"x4"x49" Crown Molding	WOO27208320	4
2"x4"x37" Crown Molding	WOO27208340	8
Coil Strap	HAR13900070	6
8 x 3" Screw SQ Drive Drywall	HAR13201140	25
8 x 2 1/2" Screw SQ Drive Drywall	HAR13201150	125
Dome Bracket	HAR13800020	6
Dome Bracket Screw	HAR13200200	30
54"x75" Plexi Dome	WOO27212140	2
2"x2"x24" M2	WOO27106900	6
2"x4"x75"	WOO27107500	4
2"x4"x51"	WOO27213880	3
1"x3"x54"	WOO27502420	1
9 1/2"x93" Lattice Panel Assembly	WOO27106880	1
2"x3"x84" Legs for Wall	WOO27102680	2
2"x4"x16" Wall Corbels	WOO27200060	2
22 1/2"x93" Lattice Panel	WOO27106480	1

**10' - 10' Lattice Wall Metal Roof**

<b>Description</b>	<b>Part Number</b>	<b>Quantity</b>
5' Lattice Panel (High)	WOO27103260	4
5' Lattice Panel (Low)	WOO27103860	4
5' Lattice Door Panel	WOO27105840	1
40 1/2" Common Rafter, No Slider	WOO27200520	12
2"x4"x53" Hip Rafter (STD), No Slider	WOO27200500	4
#5 Metal Roof Panel (R)	WOO27200800	4
#5 Metal Roof Panel (L)	WOO27200760	4
2"x2"84" Corner Connector	WOO27106120	4
2"x4"x70 1/2" Moon Roof Slider	WOO27214720	4
2"x3"x60"	WOO27107680	8
2"x4"x96" Cross Ties	WOO27211320	2
2"x4"x6 1/2" M2 Corner Stabilizer	WOO27200600	4
2"x2"x24" M2	WOO27106900	4
78"x78" Dome w/ Frame	WOO27211880	1
36" Molding Center Metal	HAR13900160	4
47 1/2" Molding Corner Metal	HAR13900180	4
#8 x 3" Screw SQ Drive Drywall	HAR13201140	25
#8 x 2 1/2" Screw SQ Drive Drywall	HAR13201150	150
Coil Strap	HAR13900070	4
8 x 1" Metal Roof Screw	HAR13200200	60
8 x 1 1/2" TEK w/ Washer	HAR13200223	20
Dome Bracket	HAR13800020	4

**10' - 10' Lattice Wall Metal Roof**

<b>Description</b>	<b>Part Number</b>	<b>Quantity</b>
5' Lattice Panel (High)	WOO27103260	4
5' Lattice Panel (Low)	WOO27103860	4
5' Lattice Door Panel	WOO27105840	1
40 1/2" Common Rafter, No Slider	WOO27200520	12
2"x4"x53" Hip Rafter (STD), No Slider	WOO27200500	4
#5 Metal Roof Panel (R)	WOO27200800	4
#5 Metal Roof Panel (L)	WOO27200760	4
2"x2"84" Corner Connector	WOO27106120	4
2"x4"x70 1/2" Moon Roof Slider	WOO27214720	4
2"x3"x60"	WOO27107680	8
2"x4"x96" Cross Ties	WOO27211320	2
2"x4"x6 1/2" M2 Corner Stabilizer	WOO27200600	4
2"x2"x24" M2	WOO27106900	4
78"x78" Dome w/ Frame	WOO27211880	1
36" Molding Center Metal	HAR13900160	4
47 1/2" Molding Corner Metal	HAR13900180	4
#8 x 3" Screw SQ Drive Drywall	HAR13201140	25
#8 x 2 1/2" Screw SQ Drive Drywall	HAR13201150	150
Coil Strap	HAR13900070	4
8 x 1" Metal Roof Screw	HAR13200200	60
8 x 1 1/2" TEK w/ Washer	HAR13200223	20
Dome Bracket	HAR13800020	4
8 x 1" Dome Bracket Screw	HAR13200200	20

**10' - 12' Lattice Wall Metal Roof**

<b>Description</b>	<b>Part Number</b>	<b>Quantity</b>
5' Lattice Panel (High)	WOO27103260	2
4' Lattice Wall Panel (High)	WOO27103220	3
5' Lattice Panel (Low)	WOO27105860	2
4' Lattice Door Panel	WOO27105820	1
#7 Metal Roof Panel Top (L)	WOO27200820	2
#7 Metal Roof Panel Bottom (L)	WOO27200840	2
#7 Metal Roof Panel Top (R)	WOO27200860	2
#7 Metal Roof Panel Bottom (R)	WOO27200880	2
#8 Metal Roof Panel Top (L)	WOO27200900	2
#8 Metal Roof Bottom (L)	WOO27200920	2
#8 Metal Roof Panel Top (R)	WOO27200940	2
#8 Metal Roof Panel Bottom (R)	WOO27200960	2
2"x2"x84" Corner Connector	WOO27106120	4
89" Hip Rafter (STD), No Slider	WOO27200460	4
2"x4"x67" Common Rafter (STD), No Slider	WOO27200480	4
2"x4"x67" Jack Rafter (L), No Slider	WOO27208000	4
2"x4"x67" Jack Rafter (R), No Slider	WOO27208020	4
2"x4"x96" Cross Ties	WOO27211320	2
2"x3"x72" Header Boards	WOO27107700	4
2"x3"x60" Header Boards	WOO27107680	4
2"x4"x22 1/2" M1	WOO27208980	2
2"x4"x46 1/2" B & BTR M1	WOO27208720	2
2"x4"x6 1/2" Corner Stabilizer M2	WOO27200600	4
2"x2"x24" M2	WOO27106900	4
22 1/2"x93" Lattice Panel	WOO27106480	1
2"x3"x84" Legs for Wall Panel	WOO27102680	2
2"x4"x16x" Wall Panel Corbels	WOO27200060	2
9 1/2"x93" Lattice Panel Assembly	WOO27106880	1
62" Metal Crown Molding	HAR13900170	4
82 3/4" Metal Crown Molding	HAR13900190	4
#8 x 3" Screw SQ Drive Drywall	HAR13201140	25
#8 x 2 1/2" Screw SQ Drive Drywall	HAR13201150	150
30"x54" Dome w/ Frame	WOO27211940	1
Coil Strap	HAR13900070	4
8 x 1" Metal Roof Screw	HAR13200200	60
8 x 1 1/2" TEK w/ Washer	HAR13200223	20
Dome Bracket	HAR13800020	4
2"x4"x43" Jack Rafter (R)	WOO27200580	4
2"x4"x43" Jack Rafter (L)	WOO27200660	4

**10' - 12' Lattice Wall Solid Roof**

<b>Description</b>	<b>Part Number</b>	<b>Quantity</b>
5' Lattice Panel (High)	WOO27103260	4
5' Lattice Panel (Low)	WOO27105860	2
4' Lattice Wall Panel (High)	WOO27103220	3
4' Lattice Wall Panel (Low)	WOO27105820	1
62"x65"x5' Solid Roof Panel (R)	WOO27202420	2
62"x65"x5' Solid Roof Panel (L)	WOO27202480	2
62"x77"x6' Solid Roof Panel (R)	WOO27203680	2
62"x77"x6' Solid Roof Panel (L)	WOO27203900	2
2"x2"x84" Corner Connector	WOO27106120	4
9 1/2"x93" Lattice Panel Assembly	WOO27106880	1
89" Hip Rafter (Standard)	WOO27207640	4
2"x4"x67" Common Rafter Standard	WOO27207940	4
2"x2"x24" M2	WOO27106900	4
2"x4"x96" Cross Ties	WOO27211320	1
2"x3"x60" Header Boards	WOO27107680	4
2"x4"x22 1/2" M1	WOO27208980	2
2"x4"x46 1/2" B & BTR M1	WOO27208720	2
2"x3"x72" Header Boards	WOO27107700	4
2"x4"x6 1/2" Corner Stabilizer	WOO27200600	4
22 1/2"x93" Lattice Panel	WOO27106480	1
2"x3"x84" Legs for Wall Panel	WOO27102680	2
2"x3"x16" Panel Corbel	WOO27200060	4
2" Metal Crown Molding	HAR13900170	4
82 3/4" Metal Crown Molding	HAR13900190	4
Coil Strap	HAR13900070	4
#8 x 3" Screw SQ Drive Drywall	HAR13201140	25
#8 x 2 1/2" Screw SQ Drive Drywall	HAR13201150	125
30"x54" Dome w/ Frame	WOO27211940	1
8 x 1" Metal Roof Screw	HAR13200200	60
Dome Bracket	HAR13800020	4

**10' - 16' Lattice Wall Metal Roof**

<b>Description</b>	<b>Part Number</b>	<b>Quantity</b>
4' Lattice Wall Panel (High)	WOO27103220	2
4' Lattice Wall Panel (Low)	WOO27107660	2
5' Lattice Wall Panel (High)	WOO27103260	2
5' Lattice Wall Panel (Low)	WOO27105860	2
2"x2"x84" Corner Connector	WOO27106120	4
2"x3"x96" Header Boards	WOO27107720	4
2"x4"x6 1/2" M2 Corner Stabilizer	WOO27200600	4
2"x4"x22 1/2" M1 Moon Roof Frame	WOO27208980	2
2"x4"x94 1/2" M1 Moon Roof Frame	WOO27208460	2
2"x4"x89" Hip Rafter (Standard), No Slider	WOO27200460	4
2"x4"x67" Common Rafter Standard, No Slider	WOO27200480	8
2"x4"x67" Jack Rafter (R), No Slider	WOO27200620	4
2"x4"x67" Jack Rafter (L), No Slider	WOO27200640	4
2"x4"x43" Jack Rafter (R), No Slider	WOO27200580	4
2"x4"x43" Jack Rafter (L), No Slider	WOO27200660	4
2"x4"x96" M2 Cross Ties	WOO27211320	1
9 1/2"x93" Lattice Panel Assembly	WOO27106880	2
22 1/2"x93" Lattice Panel	WOO27106480	1
2"x3"x84" Legs for Wall Panel	WOO27102680	4
2"x4"x16" Panel Corbel	WOO27200060	4
2"x2"x24" M2	WOO27106900	4
82 3/4" Metal Crown Molding	HAR13900190	4
62" Metal Crown Molding	HAR13900170	6
Coil Strap	HAR13900070	4
#8 x 3" Screw SQ Drive Drywall	HAR13201140	25
#8 x 2 1/2" Screw SQ Drive Drywall	HAR13201150	125
30"x102" Dome w/ Frame	WOO27212060	1
Dome Bracket	HAR13800020	4
2"x3"x60" Header Boards	WOO27107680	4
#9 Center Metal Roof Top	WOO27200980	2
#9 Center Metal Roof Bottom	WOO27200900	2
#7 Metal Roof Top (L)	WOO27200820	2
#7 Metal Roof Bottom (R)	WOO27200840	2
#7 Metal Roof Top (R)	WOO27200860	2
#7 Metal Roof Bottom (R)	WOO27200880	2
Metal Roof Panel - 8' Bottom (R)	WOO27200920	2
Metal Roof Panel - 8' Top (L)	WOO27200900	2
Metal Roof Panel - 8' Bottom (R)	WOO27200960	2
Metal Roof Panel - 8' Bottom (L)	WOO27200940	2

**10' - 16' Lattice Wall Solid Roof**

<b>Description</b>	<b>Part Number</b>	<b>Quantity</b>
4' Lattice Wall Panel (High)	WOO27103220	5
4' Lattice Wall Panel (Low)	WOO27107660	3
5' Lattice Panel (Low)	WOO27105860	2
5' Lattice Panel (High)	WOO27103260	2
62"x77 1/2"x6' Solid Roof Panel (R)	WOO27203680	2
62"x77 1/2"x6' Solid Roof Panel (L)	WOO27203900	2
2"x2"x84' Corner Connector	WOO27106120	4
2"x3"x60" Header Boards	WOO27107680	4
89" Hip Rafter (STD)	WOO27207640	4
2"x4"x22 1/2" M1 Moon Roof Frame	WOO27208980	2
2"x4"x94 1/2" M1 Moon Roof Frame	WOO27208460	2
62"x46 1/2" Center Solid Roof	WOO27204240	2
5' 52"x65" - 10"x10" Solid Roof Panel (L)	WOO27202480	2
5' 52"x65" - 10"x1-" Solid Roof Panel (R)	WOO27202420	2
2"x4"x67" Common Rafter Standard	WOO27207940	4
2"x2"x24" M2	WOO27106900	4
2"x4"x6 1/2" Corner Stabilizer	WOO27200600	4
2"x4"x96" Cross Ties	WOO27211320	2
9 1/2"x93" Lattice Panel Assembly	WOO27106880	2
2"x3"x84" Legs for Wall	WOO27102680	4
22 1/2"x93" Lattice Panel	WOO27106480	1
2"x4"x16" Panel Corbel	WOO27200060	4
2"x4"x79" Crown Molding	WOO27208260	4
2"x4"x60" Crown Molding	WOO27208300	6
Coil Strap	HAR13900070	4
#8 x 3" Screw SQ Drive Drywall	HAR13201140	25
#8 x 2 1/2" Screw SQ Drive Drywall	HAR13201150	125
30"x102" Dome w/ Frame	WOO27212060	1
Dome Bracket	HAR13800020	4
8 x 1" Dome Bracket Screw	HAR13200200	20

**12' - 12' Lattice Wall Metal Roof**

<b>Description</b>	<b>Part Number</b>	<b>Quantity</b>
4' Lattice Wall Panel (High)	WOO27103220	5
4' Lattice Wall Panel (Low)	WOO27107660	3
#7 Top Metal Roof Panel (L)	WOO27200820	4
#7 Bottom Metal Roof Panel (L)	WOO27200840	4
#7 Top Metal Roof Panel (R)	WOO27200860	4
#7 Bottom Metal Roof Panel (R)	WOO27200880	4
2"x2"x84' Corner Connector	WOO27106120	4
2"x3"x72" Header Boards	WOO27107700	8
89" Hip Rafter Standard, No Slider	WOO27200460	4
2"x4"x67" Common Rafter, No Slider	WOO27200480	4
2"x4"x60" Cross Ties M1	WOO27200140	4
2"x4"x67" Jack Rafter (R), No Slider	WOO27200620	4
2"x4"x67" Jack Rafter (L), No Slider	WOO27200640	4
2"x4"x43" Jack Rafter (R)	WOO27200580	4
2"x4"x43" Jack Rafter (L)	WOO27200660	4
2"x4"x46 1/2" B & BTR M1	WOO27208720	4
2"x4"x6 1/2" Corner Stabilizer M2	WOO27200600	4
1"x4"x18" M2 Cross Ties	WOO27209180	4
9 1/2"x93" Lattice Panel Assembly	WOO27106880	2
2"x4"x84' Legs for Wall	WOO27102680	4
2"x4"x16" Corbels	WOO27200060	4
22 1/2"x93" Lattice Panel	WOO27406480	1
2"x2"x24" M2	WOO27106900	4
62" Metal Crown Molding	HAR13900170	4
82 3/4" Metal Crown Molding	HAR13900190	4
Coil Strap	HAR13900070	4
#8 x 3" Screw SQ Drive Drywall	HAR13201140	25
#8 x 2 1/2" Screw SQ Drive Drywall	HAR13201150	125
54"x54" Dome w/ Frame	WOO27211740	1
Dome Bracket	HAR13800020	4
8 & 1 1/2" tek w/ Washer	HAR13200223	35



**12' - 12' Lattice Wall Solid Roof**

<b>Description</b>	<b>Part Number</b>	<b>Quantity</b>
4' Lattice Wall Panel (High)	WOO27103220	5
4' Lattice Wall Panel (Low)	WOO27107660	3
62"x77"x6' Solid Roof Panel (R)	WOO27203680	4
62"x77"x6' Solid Roof Panel (L)	WOO27203900	4
2"x2"x84" Corner Connector	WOO27106120	4
2"x3"x72" Header Boards	WOO27107700	8
89" Hip Rafter Standard	WOO27200460	4
2"x4"x60" Cross Ties M1	WOO27200140	2
2"x4"x67" Common Rafter Standard	WOO27207940	4
2"x2"x24" M2	WOO27106900	4
2"x4"x46 1/2" B & BTR M1	WOO27208720	4
2"x4"x6 1/2" Corner Stabilizer	WOO27200600	4
1"x4"x18" M2 Cross Ties	WOO27209180	2
9 1/2"x93" Lattice Panel Assembly	WOO27106880	2
2"x3"x84" Legs for Wall	WOO27102680	4
22 1/2"x93" Lattice Panel	WOO27106480	1
2"x4"x16" Corbel Panel	WOO27200060	4
2"x4"x79" Crown Molding	WOO27208260	4
2"x4"x60" Crown Molding	WOO27208300	4
Coil Strap	HAR13900070	4
#8 x 3" Screw SQ Drive Drywall	HAR13201140	25
#8 x 2 1/2" Screw SQ Drive Drywall	HAR13201150	125
54"x54" Dome w/Frame	WOO27211740	1
Dome Bracket	HAR13800020	4
8 x 1" Dome Bracket Screw	HAR13200200	20

**12' - 16' Lattice Wall Metal Roof**

<b>Description</b>	<b>Part Number</b>	<b>Quantity</b>
4' Lattice Wall Panel (High)	WOO27103220	5
4' Lattice Wall Panel (Low)	WOO27107660	3
#9 Center Metal Roof Top	WOO27200980	2
#9 Center Metal Roof Bottom	WOO27201000	2
#7 Center Metal Roof Top (L)	WOO27200820	4
#7 Metal Roof Panel Bottom (L)	WOO27200840	4
#7 Metal Roof Panel Top (R)	WOO27200860	4
#7 Metal Roof Panel Bottom (R)	WOO27200880	4
2"x2"x84" Corner Connector	WOO27106120	4
2"x3"x72" Top of Wall Header Boards	WOO27107700	4
2"x3"x96" Top of Wall Header Boards	WOO27107720	4
2"x4"x60" Cross Ties M1	WOO27200140	6
2"x4"x67" Jack Rafter (R), No Slider	WOO27200620	4
2"x4"x67" Jack Rafter (L), No Slider	WOO27200640	4
2"x4"x67" Common Rafter STD, No Slider	WOO27200480	8
89" Hip Rafter (Standard), No Slider	WOO27200460	4
2"x4"x43" Jack Rafter (L)	WOO27200660	4
2"x4"x43" Jack Rafter (R)	WOO27200580	4
2"x4"x46 1/2" Moon Roof Frame	WOO27208720	2
2"x4"x94 1/2" Moon Roof Frame	WOO27208460	2
1"x4"x18" M2 Cross Ties	WOO27209180	6
2"x4"x45" Center Support	WOO27210580	1
9 1/2"x93" Lattice Panel Assembly	WOO27106880	2
2"x3"x84" Legs for Wall Panel	WOO27102680	4
2"x4"x16" Corbel for Wall	WOO27200060	4
2"x4"x6 1/2" Corner Stabilizer M2	WOO27200600	4
2"x2"x24" M2	WOO27106900	4
22 1/2"x93 Lattice Panel	WOO27106480	1
82 3/4" Crown Molding Corner Metal	HAR13900190	4
62" Crown Molding Center Metal	HAR13900170	6
54"x102" Dome w/ Frame	WOO27211800	1
Coil Strap	HAR13900070	6
#8 x 3" Screw SQ Drive Drywall	HAR13201140	25
#8 x 2 1/2" Screw SQ Drive Drywall	HAR13201150	125
Dome Bracket	HAR13800020	6
8 x 1 1/2" TEK w/ Washer	HAR13200223	40
8 x 1" Screw for Roof Metal	HAR13200200	100

**12' - 16' Lattice Wall Solid Roof**

<b>Item Number</b>	<b>Description</b>	<b>Part Number</b>	<b>Quantity</b>
1	4' Lattice Wall Panel (High)	WOO27103220	6
2	' Lattice Wall Panel (Low)	WOO27107660	4
3	62"x77 1/2"x6' Solid Roof Panel (R)	WOO27203680	4
4	62"x77 1/2"x6' Solid Roof Panel (L)	WOO27203900	4
5	2"x2"x84" Corner Connection	WOO27106120	4
6	2"x4"x94 1/2" M1	WOO27208460	2
7	2"x3"x96" Header Boards	WOO27107720	4
8	2"x4"x60" Cross Ties M1	WOO27200140	4
9	2"x4"x67" Common Rafter Standard	WOO27207940	6
10	89" Hip Rafter Standard	WOO27207640	4
11	2"x3"x72" Header Boards	WOO27107700	4
12	2"x4"x6 1/2" Corner Stabilizer M2	WOO27200600	4
13	2"x4"x46 1/2" B & BTR M1	WOO27208720	2
14	1"x4"x18" M2 Cross Ties	WOO27209180	4
15	2"x4"x45" Center Support	WOO27210580	1
16	2"x2"x24" M2	WOO27106900	4
17	9 1/2"x93" Lattice Panel Assembly	WOO27106880	2
18	2"x3"x84" Legs for Wall	WOO27102680	4
19	22 1/2"x93" Lattice Panel	WOO27106480	1
20	2"x4"x16" Corbel Panel	WOO27200060	4
21	2"x4"x79 Crown Molding	WOO27208260	4
22	2"x4"x60" Crown Molding	WOO27107460	6
23	Coil Strap	HAR13900070	4
24	#8 x 3" Screw SQ Drive Drywall	HAR13201140	25
25	#8 x 2 1/2" Screw SQ Drive Drywall	HAR13201150	125
26	54"x102" Dome w/ Frame	WOO27211800	1
27	Dome Bracket	HAR13800020	4
28	8 x 1" Dome Bracket Screw	HAR13200200	20

---

# NOTES

\$5.00



# 2004 Owner's Manual

## NORTHEAST GAZEBO

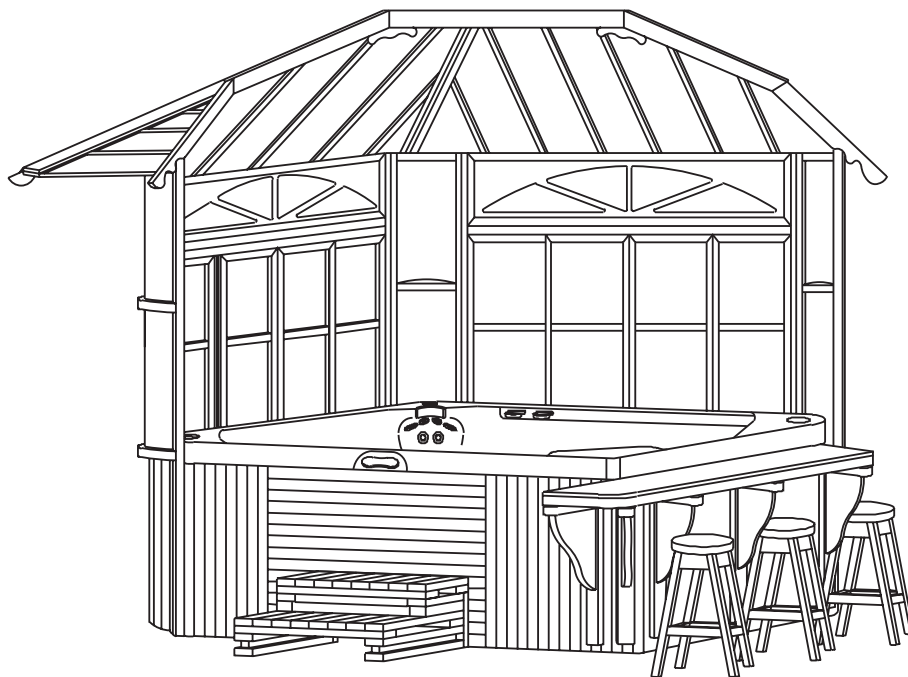

Duplication without written consent is strictly prohibited.

This Owner's Manual is for gazebos manufactured after January 1, 2004

Due to continuous improvement programs, all models, operation, and/or specifications are subject to change without prior notice.

LTR17000778

# Table of Contents

Benefits of Owning a Gazebo .....	2
Safety Instructions .....	3
Contact Information.....	4
Warranty Information .....	4
Set-up and Delivery .....	5
Assembly .....	9
Cleaning, Maintenance and Troubleshooting .....	12
Appendix .....	13
Accessories .....	14
Parts List.....	15
Notes.....	17

### BENEFITS OF OWNING A GAZEBO

Owning a gazebo allows you to have a wonderful place to unwind after a long day of work. It offers a place for you to socialize with family and friends. It offers great cover in the event that you purchase a bar-b-que and/or spa. Owning a gazebo can add character to your patio and/or yard. You can use a gazebo for whatever best suits your needs.

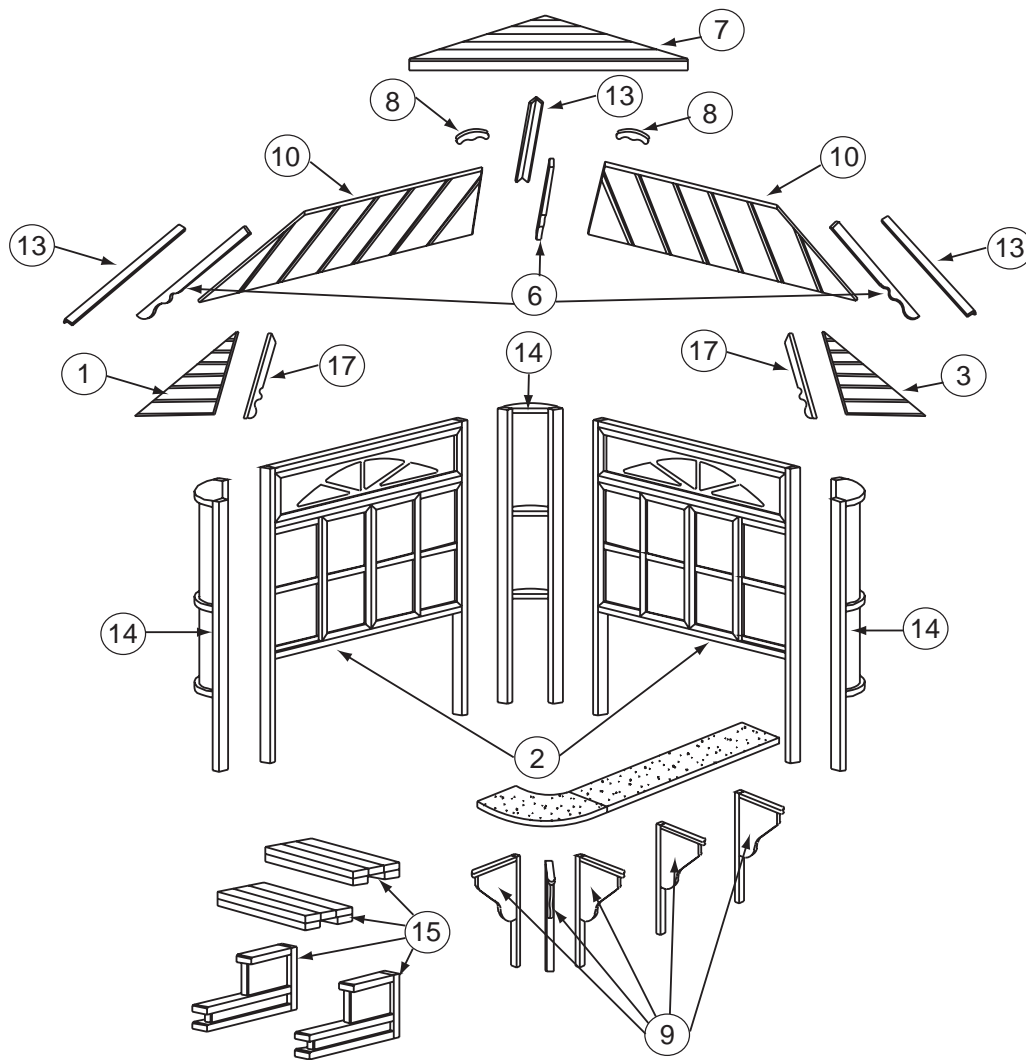

**Figure 1.** Northeast Gazebo

**NOTE:** The numbers in Figure 1 are located in the back of this manual, in the “Parts List” section.

## **SAFETY INSTRUCTIONS**

### **Carefully read and follow all safety instructions.**

1. When installing and assembling your gazebo, it is recommended that 2 or more people be involved.
2. Do not use the unit during an electrical storm. as there is a remote chance of getting struck by lightening.
3. Do not climb on top of the gazebo. While the gazebo is made out of high-quality wood and is extremely durable, the gazebo is not meant to be used as a jungle gym. Thus, falling off of the gazebo while climbing on it can result in serious injury, possibly even death.
4. Do not attempt any repair without consulting the manufacturer first. Unauthorized repair attempts will void the manufacturer's warranty.

**Save this information.**



## CONTACT INFORMATION

For customer service, please contact your authorized dealer immediately. If you need additional information and/or assistance, please contact:

C.A.I. Customer Service Department  
1462 East Ninth Street  
Pomona, CA 91766  
Toll Free: 1-800-CAL-SPAS  
Fax: 1-909-629-3890

## WARRANTY INFORMATION

See your Cal Spas Creative Wood Designs dealer for a copy of the applicable warranty, details and any questions you may have regarding the warranty coverage on your gazebo.

### Warranty Limitations

The Limited Warranty is void if the gazebo has been subject to negligence, alteration, misuse, abuse, repairs by non- C.A.I. authorized representatives, acts of God and any other cases beyond the control of C.A.I. Examples of common acts invalidating this warranty include but are not limited to:

Use of the gazebo in a non-residential application.

Scratches caused by normal use.

Damage caused by extreme weather conditions. (hot, cold, etc.)

Damage caused by dirt, sand, and/or water damage.

Damage caused by continuous operation of the gazebo with either known or unknown problems.

Damage caused by direct sunlight.

Damage caused as a result of failure to follow the assembly instructions as defined in this Owner's Manual.

This Limited Warranty applies only to gazebos normally used for personal, family, or household purposes.

This Limited Warranty specifically excludes commercial gazebos.

### Warranty Exclusions

C.A.I. warrants the gazebo from defects in material and workmanship for a period of 90 days from the original date of purchase.

**REMINDER: PLEASE DO NOT FORGET TO REGISTER YOUR NEW PRODUCT AT WWW.CALSPAS.COM.**

## DELIVERY AND SET-UP

Please make a record of the following. It will be valuable if service or replacement parts are required.

Gazebo Model: \_\_\_\_\_

Gazebo Serial Number: \_\_\_\_\_

Date Purchased: \_\_\_\_\_

Date Installed: \_\_\_\_\_

Gazebo Dealer's Phone Number: \_\_\_\_\_

Gazebo Dealer's Address: \_\_\_\_\_

Most cities and counties require permits for exterior construction and electrical circuits. In addition, some communities have codes requiring residential barriers such as fencing and/or self-closing gates on property to prevent unsupervised access to the property by children under the age of 5. Your dealer can provide information on which permits may be required and how to obtain them prior to the delivery of your equipment.

## PLANNING THE BEST LOCATION FOR YOUR GAZEBO

Here are some of the things that you will need to consider when determining where to locate your new gazebo.

### How Will You Use Your Gazebo?

How you intend to use your gazebo will help you determine where you should position it. For example, will you use your gazebo for recreational purposes? If your gazebo is mainly used for family functions, be sure to leave plenty of room around it for activity. In any case dealing in how it is to be used, you'll probably want to create a specific mood around it.

### Consider Your Privacy

In a cold- weather climate, bare trees won't provide much privacy. Think of your gazebo's surroundings during all seasons to determine your best privacy options. Consider the view of your neighbors as well, when you plan the location of your gazebo.

### Provide A View With Your Gazebo

Think about the direction you will be facing when sitting in your gazebo. Do you have a special landscaped area in your yard that you find enjoyable? Perhaps there is an area that catches a soothing breeze during the day and lovely sunset in the evening. Consider these things when you plan your location.

## PREPARING A GOOD FOUNDATION

Your gazebo needs a solid and level foundation. The area that it sits on must be able to support the weight of the gazebo and the occupants who use it. If the foundation is inadequate, it may shift or settle after the gazebo is in place, causing stress that could alter the structures figure and possibly split the wooden joints.

**NOTE:** Damage caused by inadequate or improper foundation support is not covered by the warranty. It is the responsibility of the gazebo owner to provide a proper foundation for the gazebo.

Place the gazebo on an elevated foundation (preferably a 3” concrete slab).

- \* If you are installing your gazebo on an elevated wood deck or other structure, it is highly recommended that you consult a structural engineer or contractor to ensure the structure will support the weight.
- \* It is strongly recommended that a qualified, licensed contractor prepare the foundation for your gazebo.

## Your Cal Spas Creative Wood Designs Retailer Can Help You With Foundations And More

Your retailer has a wealth of information and experience about how to get the most out of your gazebo. Your gazebo retailer also has a full line of accessories that are engineered to compliment your gazebo.

**NOTE:** It is strongly advised that you have a licensed professional install the foundation for your new gazebo. It is imperative that the foundation is level, as any damage that occurs due to an uneven foundation is not covered by the warranty.

## Size Specifications

<u>Model</u>	<u>Length</u>	<u>Width</u>
Frontier Gazebo	8'	8'
	10'	8'
	12'	8'
Cottage Gazebo	8'	8'
Cabana Gazebo	7'	7'
	7.5'	7.5'
	8'	8'
<b>Northeast Gazebo</b>	<b>7.5'</b>	<b>7.5'</b>
	<b>8'</b>	<b>8'</b>
Lattice Wall Gazebo	7'	7'
	7.5'	7.5'
	8'	8'
	12'	8'
	16'	8'
	10'	10'
	12'	10'
	16'	10'
	12'	12'

<b><u>Model</u></b>	<b><u>Length</u></b>	<b><u>Width</u></b>
Lattice Wall Gazebo (cont.)	12'	12'
	16'	12'
	10' (Octagon)	10'
	12' (Octagon)	12'
Plexi Wall Gazebo	7'	7'
	7.5'	7.5'
	8'	8'
	12'	8'
	16'	8'
	10'	10'
	12'	10'
	12'	12'
	16'	12'
	10' (Octagon)	10'
	12' (Octagon)	12'
	15' (Octagon)	15'
18' (Octagon)	18'	
Luxury Wall Gazebo	7'	7'
	7.5'	7.5'
	8'	8'
	12'	8'
	16'	8'
	10'	10'
	12'	10'
	16'	10'
	12'	12'
	16'	12'
Savannah Wall Gazebo	12'	8'
	10'	10'
	12'	10'
	16'	10'
	12'	12'
	16'	12'
	10' (Octagon)	10'
	12' (Octagon)	12'
15' (Octagon)	15'	
18' (Octagon)	18'	
Timberline Gazebo	12'	8'
	10'	10'
	12'	10'
	12'	12'
	16'	12'

<b><u>Model</u></b>	<b><u>Length</u></b>	<b><u>Width</u></b>
Lighthouse Gazebo	10'	10'
	12'	10'
	12'	12'
	16'	12'
Plantation Gazebo	10'	10'
	12'	10'
	12'	12'
	16'	12'
Chalet Gazebo	12'(Octagon)	12'
	14'(Octagon)	14'
	16'(Octagon)	16'
Victorian Gazebo	12'(Octagon)	12'
	14' (Octagon)	14'
	16' (Octagon)	16'

**NOTE:** The gazebo above that is listed in bold lettering is the gazebo that you purchased.

**NOTE:** For all gazebos, regardless of model, it is recommended that the foundation (concrete slab, railroad ties or pre-cast stepping stones) extend beyond the dimension of the gazebo. For example, if the gazebo you purchased is 12'x12', you will want your foundation to be 12.5'x12.5'. The reason for this is because it will be easier to maintain the area around the gazebo (mowing the lawn, edging, etc.) without damaging or scarring the gazebo. Also, in doing this, you will eliminate any potential problems, foundation-wise, in the future.

**NOTE:** This Owner's Manual applies to the various sizes that are included in the Northeast Gazebo line (7.5'x7.5' and 8'x8'). While the sizes will vary from gazebo to gazebo, the assembly instructions will be the same, unless otherwise noted.

## **Tools and Materials**

Utility Knife	25' Tape Measure
Cordless Drill	100' Extension Cord
1/8" Pilot Hole Drill Bit	1/2" Ratchet and Impact Drill
Electric Drill	9/16" Socket
Phillips-Head Drill Tips	1/2" Carbide Drill Bit (Masonry Bit)
Slotted-Head Drill Tips	Sandpaper (Various Grades)
Redwood Stain	Wood Putty
Gray Wash Stain	Rags

# ASSEMBLY INSTRUCTIONS

The following sections will tell you how to assemble your gazebo. If you have any questions, problems with material and/or parts, please contact your local retailer.

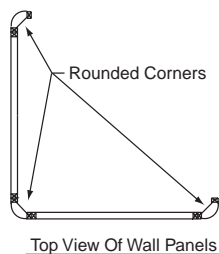
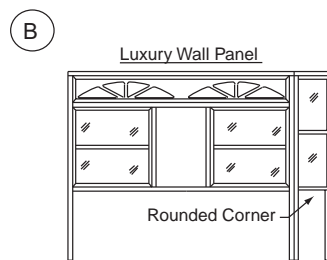
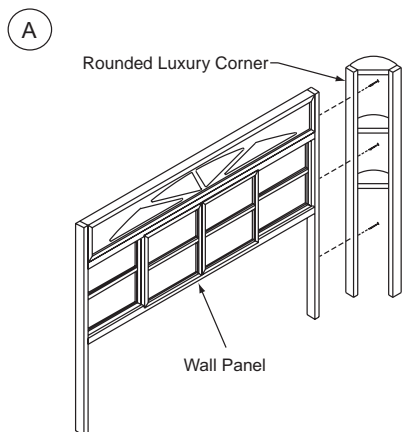

## Wall Panel Assembly

**NOTE:** All wall panels are pre-assembled at the factory before being shipped.

**NOTE:** Please follow the written steps in conjunction with the figures that are shown.

**NOTE:** The smooth side of each wall panel should be facing the inside of the gazebo.

1. Place the wall panel on a flat surface. Be sure not to set it on any surface that can possibly scratch the surface of the windows.
2. Fit the rounded luxury corner onto the wall panel and attach using the provided drywall screws (**Figure 2A**). Repeat this step for the remaining wall panels.
3. Referring to **Figure 2B**, make sure that each wall panel (2 each) is securely attached to each rounded luxury corner (3 each).

**Figure 2.** Wall Panel Assembly

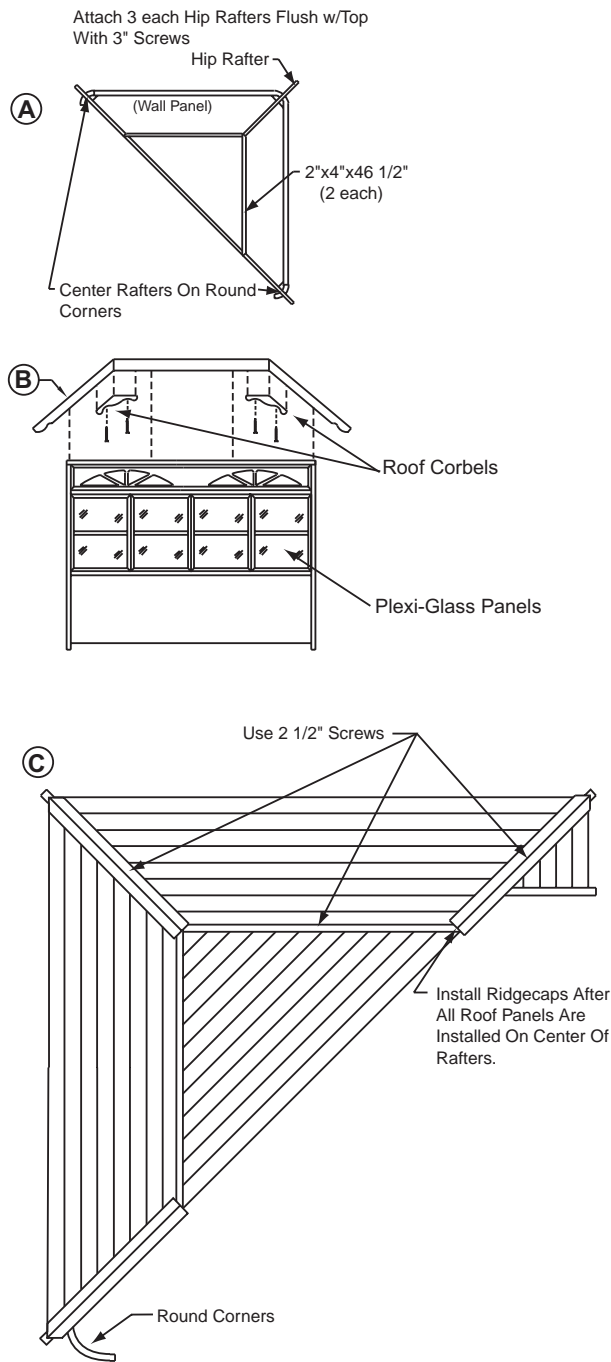

## Roof Frame Assembly

**NOTE:** It is suggested that the owner have a helper for the next steps, as heavy objects must be lifted.

1. Take 3 2"x4"x46 1/2" pieces and attach them together, making a triangle, and ensuring that the 45° angle-cut is facing out (**Figure 3A**). This is the top center frame.
2. Take three hip rafters and attach them to the 45° angle at each corner of the top center frame. Secure using drywall screws (**Figure 3A**).
3. Place the assembled roof frame onto the assembled wall panels (**Figure 3A**) and attach using the provided drywall screws.
4. Attach two roof panels (47"x109") and secure using drywall screws. Center each panel on the hip rafters (**Figure 3C**).
5. Place moon roof (48"x48"x65 1/2") on top of roof assembly and secure using drywall screws (**Figure 3C**).
6. Attach the crown molding and roof ridgecaps with 2 1/2" screws (**Figure 3B** and **3C**).

**Figure 3. Roof Assembly**

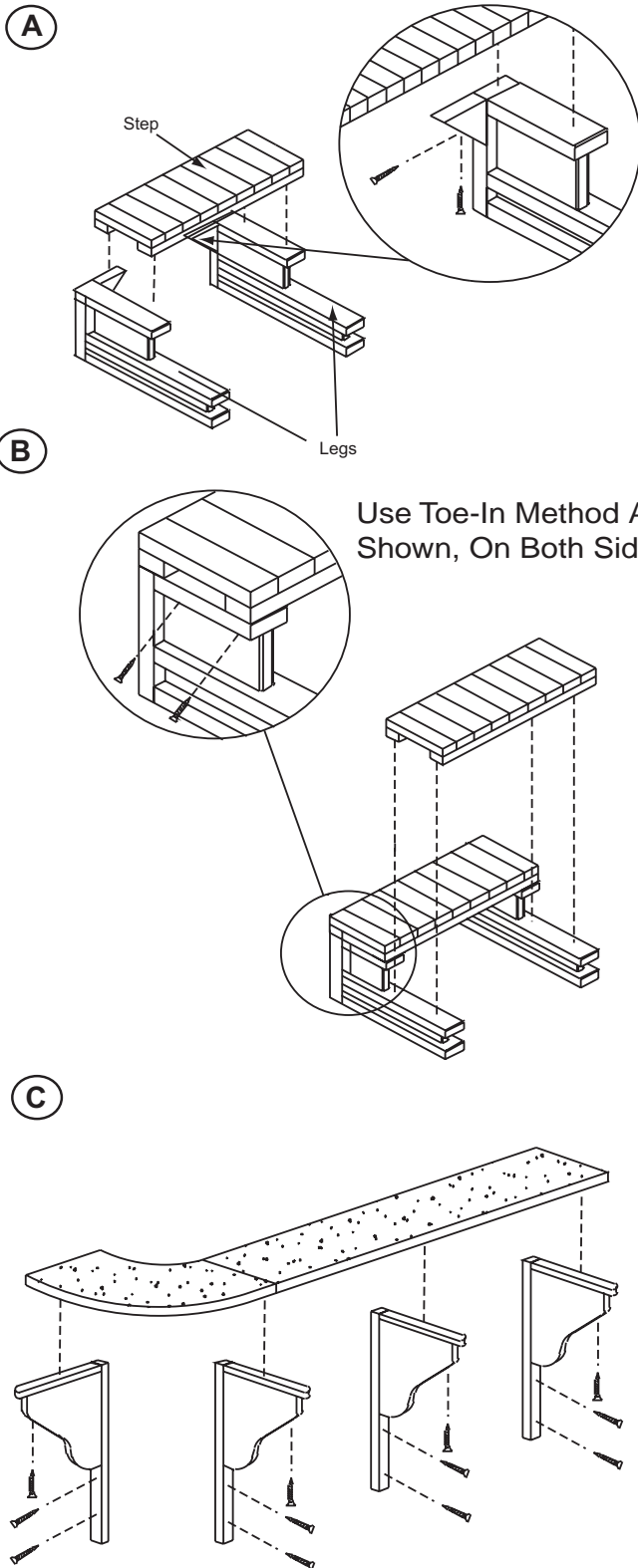

### Step and Bar Assembly

1. Stand the legs up at 5' apart. Place the upper step on top of the upper section of the step (**Figure 4A**).
2. To attach the step, screw in 4 screws (2 at each rear corner): 1 into the step leg and 1 into the step itself (see insert of **Figure 4A**).
3. Place the lower step on the lower section of the step (**Figure 4B**).
4. To attach the step, screw in 4 screws (2 on each on the outside of the step - see insert on **Figure 4B**). Use the toe-in method on both sides, as shown.

**NOTE:** The manufacturer recommends mounting corbels on the cabinet so that the bar top sits just under the spa lip.

5. Using drywall screws, mount the corbels directly to the cabinet wall (**Figure 4C**). Make sure that the corbels are horizontally level with each other.
6. Mount the bar top to the corbels with the drywall screws (**Figure 4C**). The screws must be mounted from the underside of the bar top. Make sure that the bar top rests just below the lip of the spa.

**Figure 4.** Bench and Bar Assembly



## CLEANING, MAINTENANCE AND TROUBLESHOOTING

### Cleaning

Your gazebo was designed with low cleaning and maintenance in mind. We recommend that the gazebo be cleaned at least twice a month (or more, if needed). When cleaning your gazebo, cleaning solvents are not recommended. Using a sponge and water will be fine. For ground-in dirt and grime, please refer to the following section.

### Maintenance

Maintaining your gazebo will be an easy task. We recommend that every six months you should do an inspection of the wood on your gazebo. Take note of any deformities in the wood (i.e. cracking, peeling, dirt, grime, etc.). It is recommended that you spot sand these areas with 120-grit sandpaper. When complete, wipe these areas clean with a damp rag.

When dry, you must apply a coat of stain to the sanded area. Wipe the stained area clean and reapply until the sanded area matches the rest of the gazebo.

**NOTE:** An 8oz. can of stain will be supplied with each gazebo. To replace the can of stain, please contact your local Cal Enclosures dealer.

**NOTE:** On models that have plexi-glass windows, the use of a cheese cloth and warm water should be used. These windows are made of plexi-glass and do not hold up well under the abrasive conditions that many commercial cleaners generate.

## TROUBLESHOOTING PROCEDURES

**Q: Why will the windows on the gazebo not stay open/closed?**

**A:** This is most likely due to the fact that your foundation is not level. Foundations will most likely have a 1/4" pitch for drainage reasons. To rectify this problem, the gazebo must be shimmed on the low side. Using a standard level, shim the low side so that the gazebo is level.

**Q: Why won't the roof panels sit correctly on the roof frame?**

**A:** Check the top plate on the top center frame and make sure it is level and installed correctly.

**Q: My roof and wall panels are not lining up correctly and there are small gaps in the joint seams. Why is this?**

**A:** The main support post is not "plumb" (meaning vertically level). You must go back and make sure that the main support post is plumb. Also, you must make sure that each of your main support beams is "square" in relation to the main support post (meaning that there is a 90° angle when the main support post and the main support beam intersect).

## APPENDIX

The items that will be covered in this section will consist of the following:

Accessories

Part Numbers

Notes

In order for your retailer to expedite your order, for parts and accessories, it is recommended that you have the information that you attained in the Set-Up and Delivery section. Customer Service will want all this information for warranty purposes.

## ACCESSORIES

The following is a list of all the accessories that you can use with your Cal Spa Creative Wood Designs Gazebo. If you wish to order an accessory, feel free to contact your dealer with the desired part name and part number, or visit [www.calspa.com](http://www.calspa.com).

<u>Description</u>	<u>Size</u>	<u>Wood</u>	<u>Part Number</u>	
			<u>Cal Stone</u>	<u>Deluxe Stone</u>
Bar Top	11'	WOOD289	WOOD289CS	WOOD289DS
	80'	WOOD288	WOOD288CS	WOOD288DS
	75'	WOOD287	WOOD287CS	WOOD287DS
Round Corner		WOOD199	WOOD199CS	WOOD199DS
Storage Bench	11'	WOOD905	WOOD905CS	WOOD905DS
	80'	WOOD902	WOOD902CS	WOOD902DS
	75'	WOOD901	WOOD901CS	WOOD901DS
Crescent S/B		WOOD900	WOOD900CS	WOOD900DS
Bar Corbel		WOO270405060		
Bench Leg		WOO27405020		
Bar Stool		WOOD127	WOOD127CS	WOOD127DS
Surround Step	11'	WOOD296		
	80'	WOOD297		
	75'	WOOD298		
Crescent Step		WOOD214		
30' Step		WOOD107		
30" Storage Step w/Box		WOOD133		
5' Step		WOOD109		
5' Step Storage w/Box		WOOD134		
30" Step w/Handrail		WOOD107-2		
Round Planter		WOOD101		
Square Planter		WOOD100		
Crown Planter		WOOD189		
Octagon Planter		WOOD148		
Crescent Planter		WOOD168		
Bench	11'	WOOD923	WOOD923CS	WOOD923DS
	80'	WOOD922	WOOD922CS	WOOD922DS
	75'	WOOD921	WOOD921CS	WOOD921DS
Crescent Bench		WOOD920	WOOD920CS	WOOD920DS
Privacy Panel		WOOD183		
30" Step (3 tier)	30"	WOOD108		
30" Step (3 Tier with Handrail)	30"	WOOD108-2		
Towel/Wine Glass Rack	4'	WOOD113		
Towel/Wine Glass Rack	5'	WOOD113-5		
Wine Glass Hanger		WOOD114		
Towel Tree		WOOD169		
Kidzone Playhouse		KDZ100		
Corner Towel Bar		WOO27402175		

# PARTS LIST

## 7.5'x 7.5' NORTHEAST

<u>Item Number</u>	<u>Description</u>	<u>Part Number</u>	<u>Quantity</u>
1	18"x19" Left Roof Side Solid	WOO27201026	1
2	750 Luxury Wall Panel w/Sliding	WOO27104380	2
3	18"x19" Right Roof Side Solid	WOO27201025	1
4	Jack Rafter, Left	WOO27216526	1
5	Jack Rafter, Right	WOO27216525	1
6	53" Hip Rafter, Luxury	WOO27207800	3
7	40"x40"x54 1/2" Triangle Moon-Roof Frame	WOO27208711	1
8	2'x2'x4.5' Roof Panel Support	WOO27106700	2
9	2'x3'x7 1/2' XL Corbel Support	WOO27212360	4
10	33"x101" 750 Solid Roof Panel	WOO27205140	2
11	8"x3" Screw SQ Drive Drywall	HAR13201140	20
12	8"x2 1/2" Screw SQ Drive Drywall	HAR13201150	100
13	2"x4"x49" Crown Molding	WOO27208320	3
14	Luxury Round Corners XL Series	WOO27106000	3
15	5' Step	WOO27406880	1
16	Bar Stools	WOO27403300	4
17	2"x4"x9" Roof Support Corbel NEPKG	WOO27211521	2

**8'x 8' NORTHEAST**

<b>Item Number</b>	<b>Description</b>	<b>Part Number</b>	<b>Quantity</b>
1	18"x19" Left Roof Side Solid	WOO27201026	1
2	8080 Luxury Wall Panel w/Siding	WOO27103900	2
3	18"x19" Right Roof Side Solid	WOO27201025	1
4	Jack Rafter, Left	WOO27216526	1
5	Jack Rafter, Right	WOO27216525	1
6	53" Hip Rafter, Luxury	WOO27207800	3
7	48"x48"x65 1/2" Triangle Moon-Roof Frame	WOO27208710	1
8	2'x2'x4.5' Roof Panel Support	WOO27106700	2
9	2'x3'x7 1/2' XL Corbel Support	WOO27212360	4
10	47"x109" 800 Solid Roof Panel	WOO27204700	2
11	8"x3" Screw SQ Drive Drywall	HAR13201140	20
12	8"x2 1/2" Screw SQ Drive Drywall	HAR13201150	100
13	2"x4"x49" Crown Molding	WOO27208320	3
14	Luxury Round Corners XL Series	WOO27106000	3
15	5' Step	WOO27406880	1
16	Bar Stools	WOO27403300	4
17	2"x4"x9" Roof Support Corbel NEPKG	WOO27211521	2

# NOTES

\$5.00



# 2004 Owner's Manual

## PLEXI GAZEBO

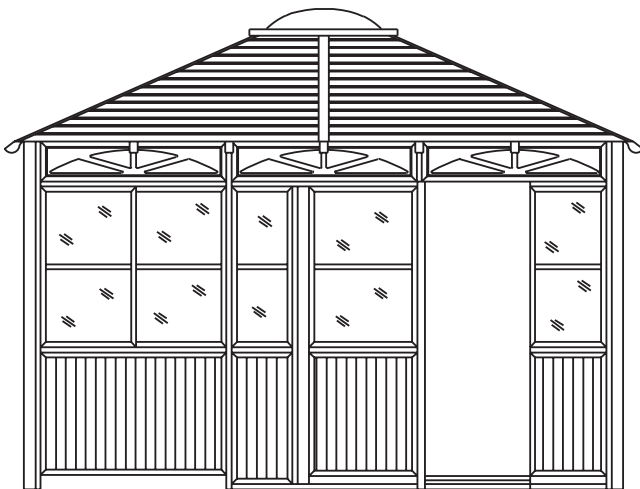

Rectangle

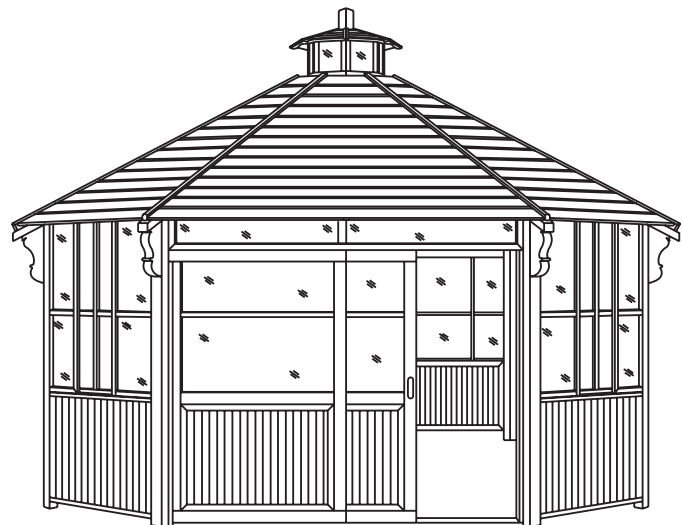

Octagon

Duplication without written consent is strictly prohibited.  
This Owner's Manual is for gazebos manufactured after January 1, 2004  
Due to continuous improvement programs, all models, operation, and/or specifications are subject to change without prior notice.  
LTR17000781

# Table of Contents

Benefits of Owning a Gazebo .....	2
Safety Instructions .....	3
Contact Information.....	4
Warranty Information .....	4
Set-up and Delivery .....	5
Assembly .....	9
Cleaning, Maintenance and Troubleshooting .....	16
Appendix .....	17
Accessories .....	18
Parts List.....	19
Notes.....	21



### BENEFITS OF OWNING A GAZEBO

Owning a gazebo allows you to have a wonderful place to unwind after a long day of work. It offers a place for you to socialize with family and friends. It offers great cover in the event that you purchase a bar-b-que and/or spa. Owning a gazebo can add character to your patio and/or yard. You can use a gazebo for whatever best suits your needs.

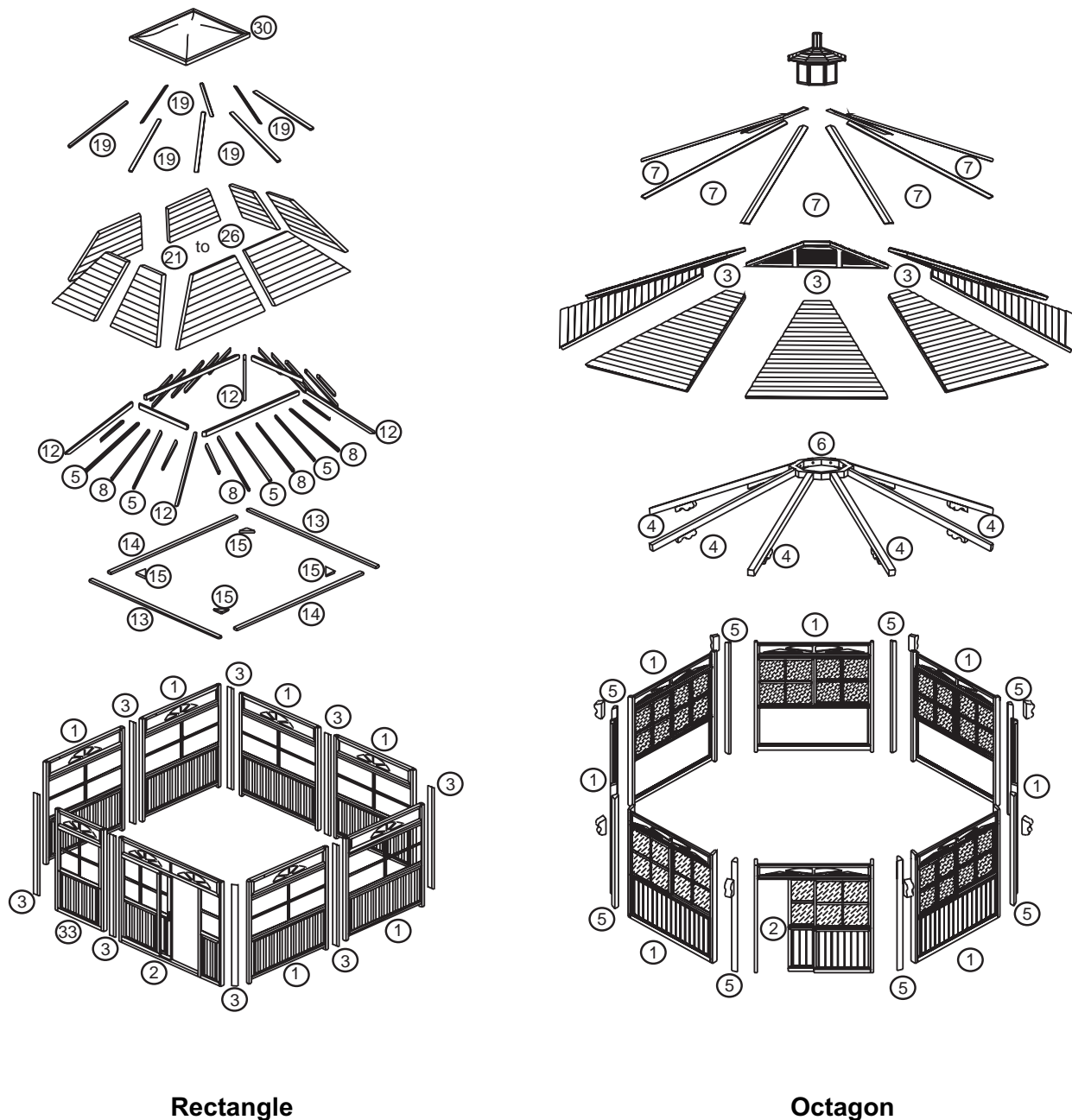

**Rectangle**

**Octagon**

**Figure 1. Plexi Gazebo**

**NOTE:** The numbers in Figure 1 are located in the back of this manual, in the “Parts List” section.

## **SAFETY INSTRUCTIONS**

### **Carefully read and follow all safety instructions.**

1. When installing and assembling your gazebo, it is recommended that 2 or more people be involved.
2. Do not use the unit during an electrical storm, as there is a remote chance of getting struck by lightning.
3. Do not climb on top of the gazebo. While the gazebo is made out of high-quality wood and is extremely durable, the gazebo is not meant to be used as a jungle gym. Thus, falling off of the gazebo while climbing on it can result in serious injury, possibly even death.
4. Do not attempt any repair without consulting the manufacturer first. Unauthorized repair attempts will void the manufacturer's warranty.

**Save this information.**

## CONTACT INFORMATION

For customer service, please contact your authorized dealer immediately. If you need additional information and/or assistance, please contact:

C.A.I. Customer Service Department  
1462 East Ninth Street  
Pomona, CA 91766  
Toll Free: 1-800-CAL-SPAS  
Fax: 1-909-629-3890

## WARRANTY INFORMATION

See your Cal Spas Creative Wood Designs dealer for a copy of the applicable warranty, details and any questions you may have regarding the warranty coverage on your gazebo.

### Warranty Limitations

The Limited Warranty is void if the gazebo has been subject to negligence, alteration, misuse, abuse, repairs by non- C.A.I. authorized representatives, acts of God and any other cases beyond the control of C.A.I. Examples of common acts invalidating this warranty include but are not limited to:

Use of the gazebo in a non-residential application.

Scratches caused by normal use.

Damage caused by extreme weather conditions. (hot, cold, etc.)

Damage caused by dirt, sand, and/or water damage.

Damage caused by continuous operation of the gazebo with either known or unknown problems.

Damage caused by direct sunlight.

Damage caused as a result of failure to follow the assembly instructions as defined in this Owner's Manual.

This Limited Warranty applies only to gazebos normally used for personal, family, or household purposes.

This Limited Warranty specifically excludes commercial gazebos.

### Warranty Exclusions

C.A.I. warrants the gazebo from defects in material and workmanship for a period of 90 days from the original date of purchase.

**REMINDER: PLEASE DO NOT FORGET TO REGISTER YOUR NEW PRODUCT AT [WWW.CALSPAS.COM](http://WWW.CALSPAS.COM).**

## DELIVERY AND SET-UP

Please make a record of the following. It will be valuable if service is required.

Gazebo Model: \_\_\_\_\_

Gazebo Serial Number: \_\_\_\_\_

Date Purchased: \_\_\_\_\_

Date Installed: \_\_\_\_\_

Gazebo Dealer's Phone Number: \_\_\_\_\_

Gazebo Dealer's Address: \_\_\_\_\_

Most cities and counties require permits for exterior construction and electrical circuits. In addition, some communities have codes requiring residential barriers such as fencing and/or self-closing gates on property to prevent unsupervised access to the property by children under the age of 5. Your dealer can provide information on which permits may be required and how to obtain them prior to the delivery of your equipment.

## PLANNING THE BEST LOCATION FOR YOUR GAZEBO

Here are some of the things that you will need to consider when determining where to locate your new gazebo.

### How Will You Use Your Gazebo?

How you intend to use your gazebo will help you determine where you should position it. For example, will you use your gazebo for recreational purposes? If your gazebo is mainly used for family functions, be sure to leave plenty of room around it for activity. In any case dealing in how it is to be used, you'll probably want to create a specific mood around it.

### Consider Your Privacy

In a cold- weather climate, bare trees won't provide much privacy. Think of your gazebos surroundings during all seasons to determine your best privacy options. Consider the view of your neighbors as well, when you plan the location of your gazebo.

### Provide A View With Your Gazebo

Think about the direction you will be facing when sitting in your gazebo. Do you have a special landscaped area in your yard that you find enjoyable? Perhaps there is an area that catches a soothing breeze during the day and lovely sunset in the evening. Consider these things when you plan your location.

## PREPARING A GOOD FOUNDATION

Your gazebo needs a solid and level foundation. The area that it sits on must be able to support the weight of the gazebo and the occupants who use it. If the foundation is inadequate, it may shift or settle after the gazebo is in place, causing stress that could alter the structures figure and possibly split the wooden joints.

**NOTE:** Damage caused by inadequate or improper foundation support is not covered by the warranty. It is the responsibility of the gazebo owner to provide a proper foundation for the gazebo.

Place the gazebo on an elevated foundation (preferably a 3” concrete slab).

\* If you are installing your gazebo on an elevated wood deck or other structure, it is highly recommended that you consult a structural engineer or contractor to ensure the structure will support the weight.

\* It is strongly recommended that a qualified, licensed contractor prepare the foundation for your gazebo.

## Your Cal Spas Creative Wood Designs Retailer Can Help You With Foundations And More

Your retailer has a wealth of information and experience about how to get the most out of your gazebo. Your gazebo retailer also has a full line of accessories that are engineered to compliment your gazebo.

**NOTE:** It is strongly advised that you have a licensed professional install the foundation for your new gazebo. It is imperative that the foundation is level, as any damage that occurs due to an uneven foundation is not covered by the warranty.

## Size Specifications

<u>Model</u>	<u>Length</u>	<u>Width</u>
Frontier Gazebo	8'	8'
	10'	8'
	12'	8'
Cottage Gazebo	8'	8'
Cabana Gazebo	7'	7'
	7.5'	7.5'
	8'	8'
Northeast Gazebo	7.5'	7.5'
	8'	8'
Lattice Wall Gazebo	7'	7'
	7.5'	7.5'
	8'	8'
	12'	8'
	16'	8'
	10'	10'
	12'	10'
	16'	10'
	12'	12'

<b><u>Model</u></b>	<b><u>Length</u></b>	<b><u>Width</u></b>
Lattice Wall Gazebo (cont.)	12'	12'
	16'	12'
	10' (Octagon)	10'
	12' (Octagon)	12'
<b>Plexi Wall Gazebo</b>	7'	7'
	7.5'	7.5'
	8'	8'
	12'	8'
	16'	8'
	10'	10'
	12'	10'
	12'	12'
	16'	12'
	10' (Octagon)	10'
	12' (Octagon)	12'
15' (Octagon)	15'	
18' (Octagon)	18'	
Luxury Wall Gazebo	7'	7'
	7.5'	7.5'
	8'	8'
	12'	8'
	16'	8'
	10'	10'
	12'	10'
	16'	10'
	12'	12'
16'	12'	
Savannah Wall Gazebo	12'	8'
	10'	10'
	12'	10'
	16'	10'
	12'	12'
	16'	12'
	10' (Octagon)	10'
	12' (Octagon)	12'
15' (Octagon)	15'	
18' (Octagon)	18'	
Timberline Gazebo	12'	8'
	10'	10'
	12'	10'
	12'	12'
	16'	12'

<b><u>Model</u></b>	<b><u>Length</u></b>	<b><u>Width</u></b>
Lighthouse Gazebo	10'	10'
	12'	10'
	12'	12'
	16'	12'
Plantation Gazebo	10'	10'
	12'	10'
	12'	12'
	16'	12'
Chalet Gazebo	12'(Octagon)	12'
	14'(Octagon)	14'
	16'(Octagon)	16'
Victorian Gazebo	12'(Octagon)	12'
	14' (Octagon)	14'
	16' (Octagon)	16'

**NOTE:** The gazebo above that is listed in bold lettering is the gazebo that you purchased.

**NOTE:** For all gazebos, regardless of model, it is recommended that the foundation (concrete slab, railroad ties or pre-cast stepping stones) extend beyond the dimension of the gazebo. For example, if the gazebo you purchased is 12'x12', you will want your foundation to be 12.5'x12.5'. The reason for this is because it will be easier to maintain the area around the gazebo (mowing the lawn, edging, etc.) without damaging or scarring the gazebo. Also, in doing this, you will eliminate any potential problems, foundation-wise, in the future.

**NOTE:** This Owner's Manual applies to the various sizes that are included in the Plexi Gazebo line (7'x7', 7.5'x7.5', 8'x8', 12'x8', 16'x8', 10'x10', 12'x10', 16'x10', 12'x12', and 16'x12'; Octagon - 10'x10', 12'x12', 15'x15' and 18'x18'). While the sizes will vary from gazebo to gazebo, the assembly instructions will be the same, unless otherwise noted.

## Tools and Materials

Utility Knife	25' Tape Measure
Cordless Drill	100' Extension Cord
1/8" Pilot Hole Drill Bit	1/2" Ratchet and Impact Drill
Electric Drill	9/16" Socket
Phillips-Head Drill Tips	1/2" Carbide Drill Bit (Masonry Bit)
Slotted-Head Drill Tips	Sandpaper (Various Grades)
Redwood Stain	Wood Putty
Gray Wash Stain	Rags

# Assembly Instructions

The following sections are broken into two parts: Octagon and Rectangle. These sections will tell you how to assembly your gazebo. If you have any questions, problems with material and/or parts, please contact your local retailer.

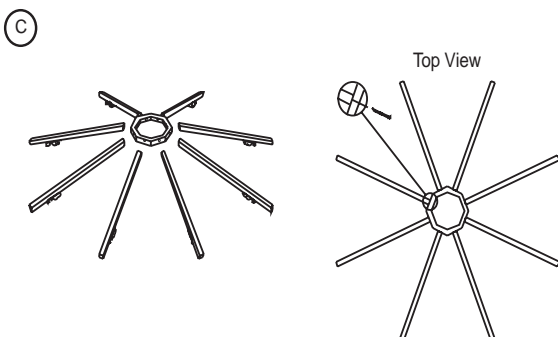
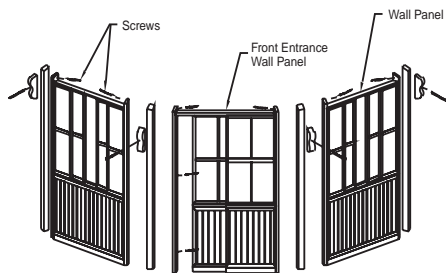
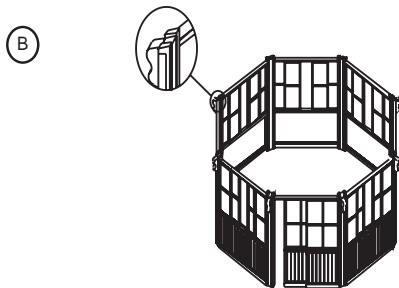
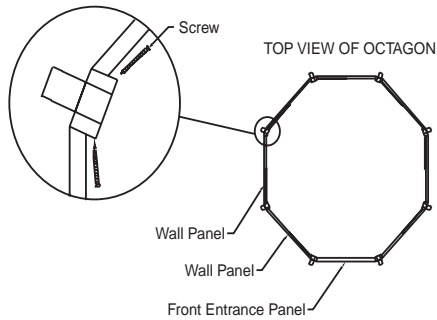
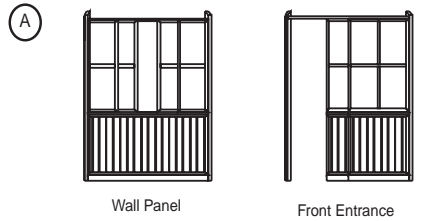

## Wall Panel Assembly - Octagon

**NOTE:** All wall panels are pre-assembled at the factory before being shipped.

**NOTE:** Please follow the written steps in conjunction with the figures that are shown.

**NOTE:** The smooth side of each wall panel should be facing the inside of the gazebo.

**NOTE:** Check the parts list that came with your gazebo and make sure that all the parts are present.

1. Stand panels up vertically with the flush side of the panel facing inward (fit panels together as shown in **Figure 2A**).
2. Drill holes in all 2"x4" boards. The holes have already been drilled for the wall panels. Line up the holes and mark the 2"x4" and drill accordingly.
3. Insert the provided 7"x5/16" threaded rod and washer into the pre-drilled holes and tighten with the nut (**Figure 2B**).
4. To build the roof frame assembly, attach each roof support (8 total) to the 8-sided roof center support using the provided drywall screws (**Figure 2C**).

**Figure 2.** Wall Panel Assembly - Octagon



### COMPOSITION ROOF ASSEMBLY

**NOTE:** Check the parts list that came with your gazebo and make sure that all the parts are present. Also, please follow the written steps in conjunction with the figures that are shown.

1. With the assistance of another person, place the roof frame assembly onto the assembled wall panels. There is a notch at each corner of the wall panel assembly (8 total). Place the roof frame in these notches and secure with drywall screws (**Figure 3A - inset**).
2. Place the 4-sided roof tiles (8 total) in the corresponding positions on the roof frame (narrow end on top, wide end on the bottom). Make sure each roof tile is centered on each support before securing. Secure using drywall screws (**Figure 3B**). Repeat this step until the roof frame is completely covered.
3. Attach each ridgecap with drywall screws (**Figure 3C**). Repeat this step until each roof joint is covered with a ridgecap.
4. With the aid of a ladder, place the cupola (birdhouse) on top of the finished gazebo. Using the drywall screws, attach the cupola to the roof frame (**Figure 3D**).

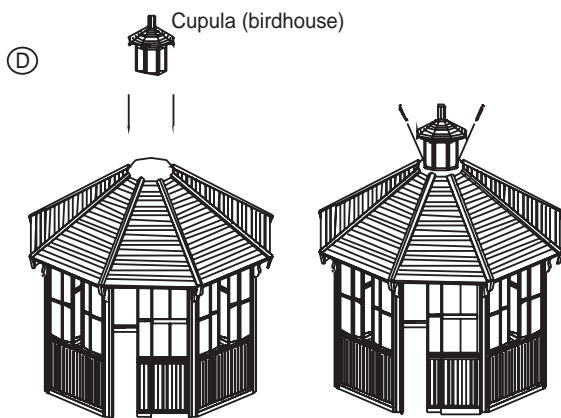
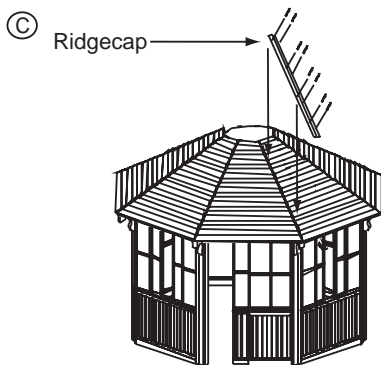
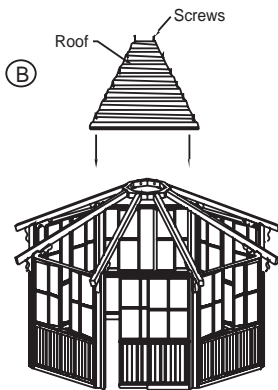
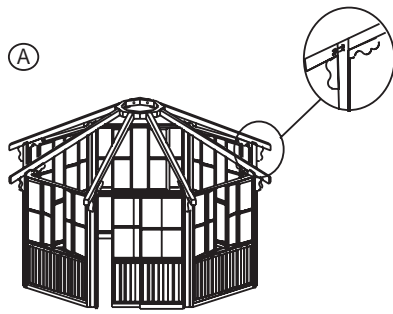

**Figure 3.** Composition Roof Assembly

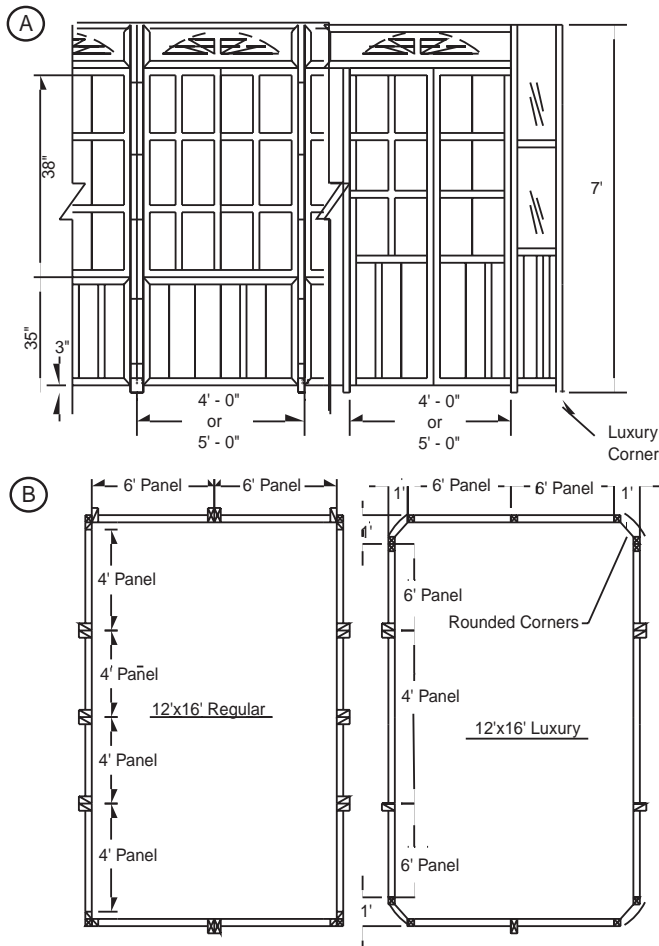

**Figure 4.** Wall Panel Assembly - Rectangle

## Wall Panel Assembly - Rectangle

**NOTE:** The assembly instructions contained in this manual are for the Plexi Rectangle Gazebo that measures 12'x16'. The assembly instructions will be the same for the 8'x12', 10'x10', 10'x12', 10'x16' and 12'x12' models. The only difference in the assembly of these five models is the amount of steps the owner must perform.

**NOTE:** All wall panels are pre-assembled at the factory before being shipped.

**NOTE:** Please follow the written steps in conjunction with the figures that are shown.

**NOTE:** The smooth side of each wall panel should be facing the inside of the gazebo.

**NOTE:** Check the parts list that came with your gazebo and make sure that all the parts are present.

1. Stand two panels up side by side. Attach the panels together using 5 drywall screws (**Figure 4A**).
2. At each wall seam, attach a 2"x4" Splice. This will tie-in and stabilize the walls (**Figure 4A**).
3. Repeat this step until all the panels are attached. **Figure 4B** will show you which order to go in.

**NOTE:** The rounded corners attach to the wall panels the same way, with 5 drywall screws. The owner must use care when securing the wall panel and rounded corner together, as any damage incurred during assembly is not covered by the warranty.

**NOTE:** Rounded corners only come on the Luxury model.

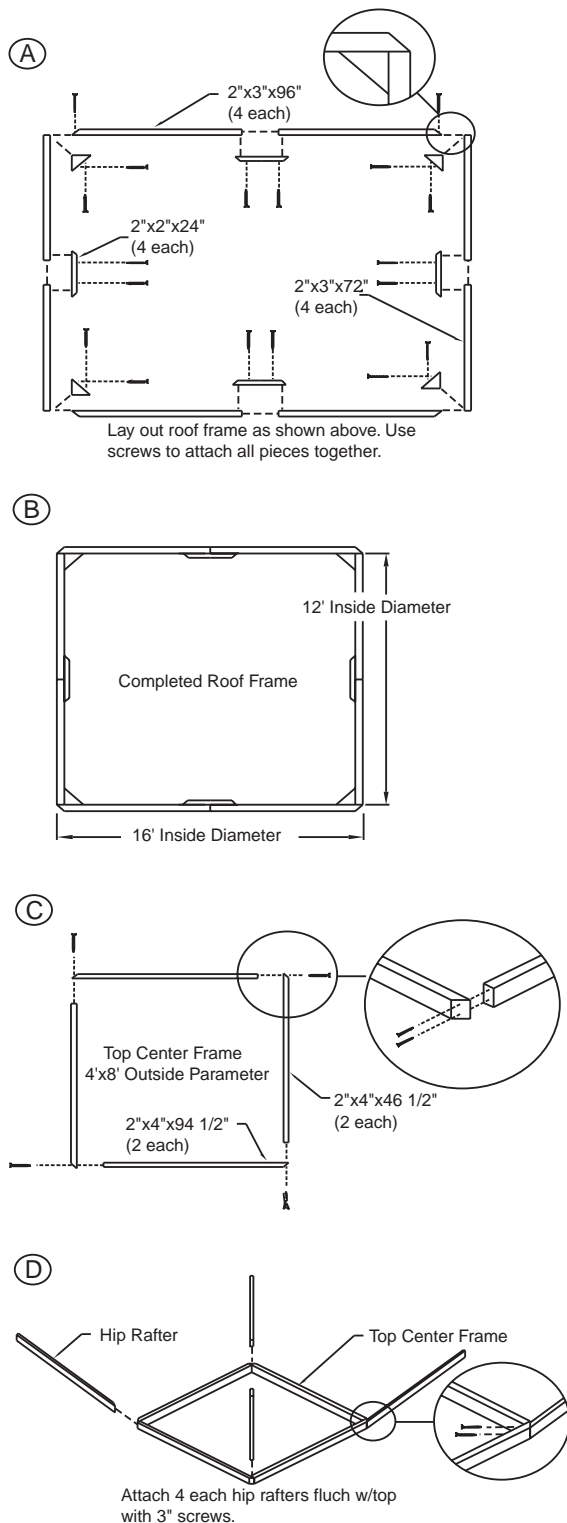

### Roof Frame Assembly

When assembling the roof frame, it is recommended that you lay everything out and assemble it on a flat surface. The owner should also note that there are different sizes in the Plexi line of gazebos. These directions are generalized, relating to measurements.

**NOTE:** Check the parts list that came with your gazebo and make sure that all the parts are present. Also, please follow the written steps in conjunction with the figures that are shown.

1. Take four 2"x3"x96" pieces of wood (these are the sides) and four 2"x3"x72" pieces of wood (these are the ends) lay them out on the ground (**Figure 3A**), in effect making a rectangle.
2. Place corner stabilizers (4 each) and attach in each corner using drywall screws. Attach 2"x2"x24" splice (4 each) at each center joint. This will reinforce the roof frame (**Figure 3A**).
3. Use the provided drywall screws to attach all the pieces together (**Figure 3B**).
4. Attach each corner together with the provided screws, making sure to keep the 45° corners pointing outward (**Figure 3C - inset**). This is the top center frame.
5. Take the hip rafters (4 each) and attach them to each corner of the top center frame. Make sure that the 45° corner matches the 45° end on the hip rafters (**Figure 3D**).

**Figure 5. Roof Frame Assembly**

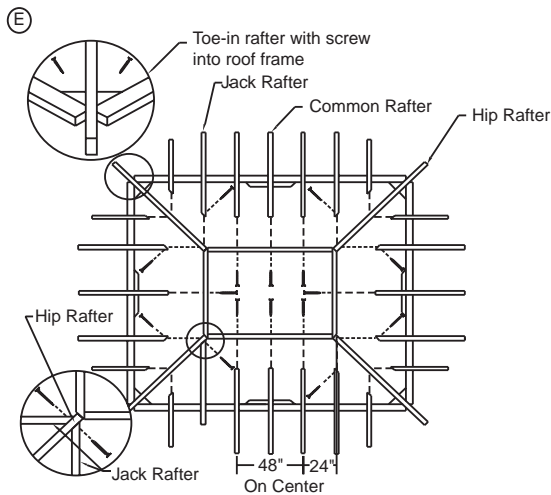

6. Take 4 common rafters and attach them to the middle of each side of the top center frame assembly (**Figure 3E**). Use the toe-in method (**see inset**).
7. With the common rafters now installed, attach the the remaining jack rafters using the toe-in method. Make sure that each jack rafter is spaced evenly apart. This will ensure sufficient anchoring points for the roof panels.
8. **Figure 3F** shows what the roof frame will look like when it is completed.

**NOTE:** It is recommended that you have an assistant for the following step.

9. Place the assembled roof section on top of the wall panel assembly. Anchor the roof section by using drywall screws (**Figure 3G**).

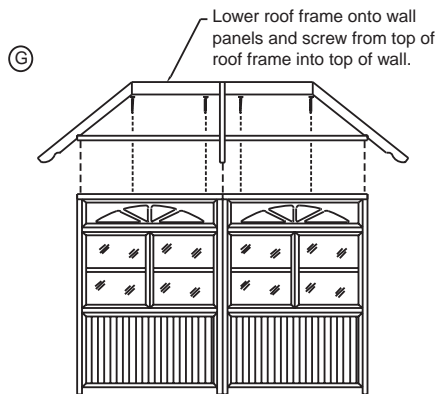
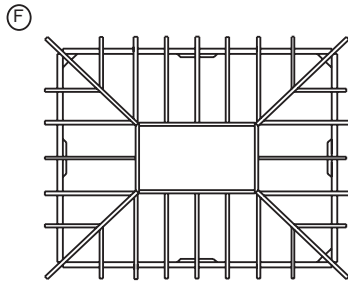

**Figure 5. Roof Frame Assembly**

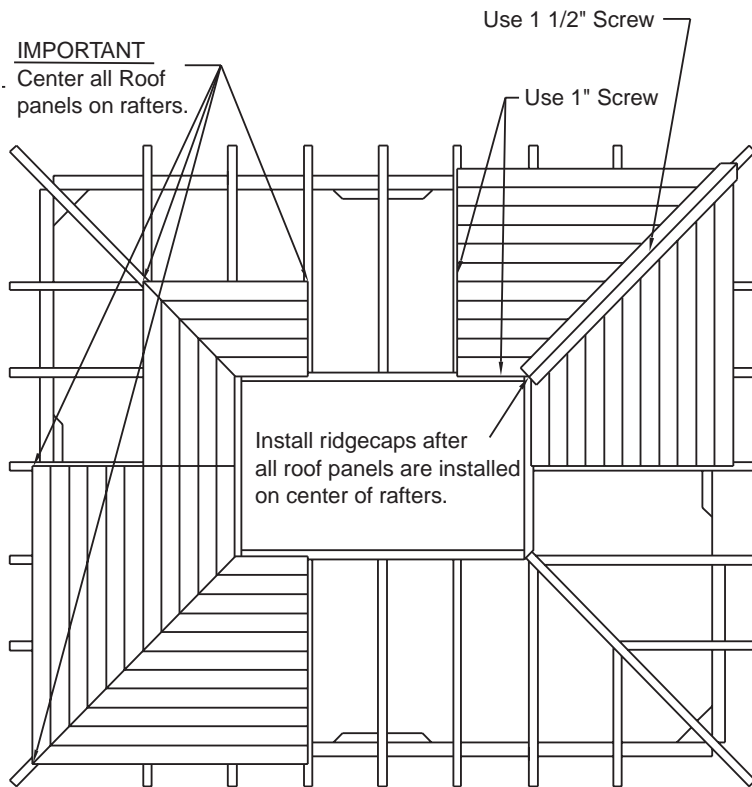

## Roof Panel Installation

**NOTE:** It is strongly recommended that you use a ladder for the final steps of the gazebo assembly.

1. Place each roof panel in place (with the edge being flush with the center of the hip rafter) and mount using drywall screws (**Figure 6B**).
2. Using the provided hardware, mount the dome bracket (**Figure 4C**).
3. Use 1 1/2" drywall screws to mount all ridge caps (**Figure 4C**).
4. Set the roof assembly onto the wall panel assembly and attach using drywall screws.

**Figure 6.** Roof Panel Assembly

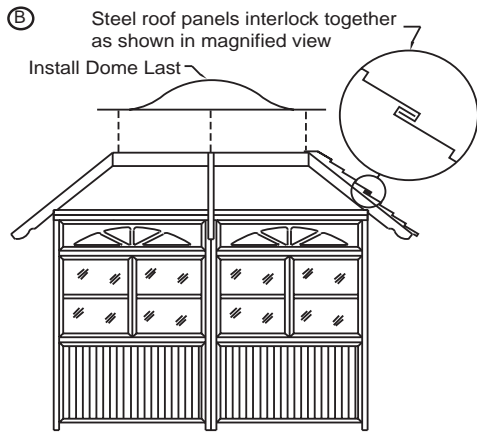
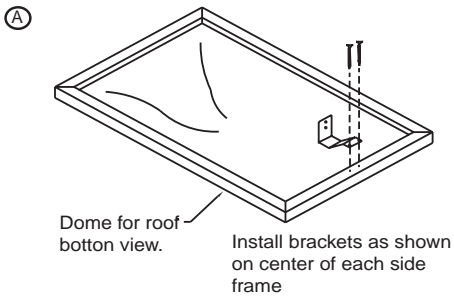

### Dome Installation

**NOTE:** The final steps of the gazebo assembly will require the use of a ladder.

1. Set the dome light assembly into the dome housing (**Figure 7A**).
2. From the inside the gazebo secure the dome assembly to the roof assembly using the dome brackets and drywall screws (**Figure 7B**). There will be four dome brackets that will connect to each side of the dome frame.

**Figure 7.** Dome Assembly

# CLEANING, MAINTENANCE AND TROUBLESHOOTING

## Cleaning

Your gazebo was designed with low cleaning and maintenance in mind. We recommend that the gazebo be cleaned at least twice a month (or more, if needed). When cleaning your gazebo, cleaning solvents are not recommended. Using a sponge and water will be fine. For ground-in dirt and grime, please refer to the following section.

## Maintenance

Maintaining your gazebo will be an easy task. We recommend that every six months you should do an inspection of the wood on your gazebo. Take note of any deformities in the wood (i.e. cracking, peeling, dirt, grime, etc.). It is recommended that you spot sand these areas with 120-grit sandpaper. When complete, wipe these areas clean with a damp rag.

When dry, you must apply a coat of stain to the sanded area. Wipe the stained area clean and reapply until the sanded area matches the rest of the gazebo.

**NOTE:** An 8oz. can of stain will be supplied with each gazebo. To replace the can of stain, please contact your local Cal Enclosures dealer.

**NOTE:** On models that have plexi-glass windows, the use of a cheese cloth and warm water should be used. These windows are made of plexi-glass and do not hold up well under the abrasive conditions that many commercial cleaners generate.

## TROUBLESHOOTING PROCEDURES

**Q: Why will the windows on the gazebo not stay open/closed?**

**A:** This is most likely due to the fact that your foundation is not level. Foundations will most likely have a 1/4" pitch for drainage reasons. To rectify this problem, the gazebo must be shimmed on the low side. Using a standard level, shim the low side so that the gazebo is level.

**Q: Why won't the roof panels not sit correctly on the roof frame?**

**A:** Check the top plate on the top center frame and make sure it is level and installed correctly.

**Q: My roof and wall panels are lining up correctly and there are small gaps in the joint seams. Why is this?**

**A:** The main support post is not "plumb" (meaning vertically level). You must go back and make sure that the main support post is plumb. Also, you must make sure that each of your main support beams is "square" in relation to the main support post (meaning that there is a 90° angle when the main support post and the main support beam intersect).

## **APPENDIX**

The items that will be covered in this section will consist of the following:

Accessories

Part Numbers

Notes

In order for your retailer to expedite your order, for parts and accessories, it is recommended that you have the information that you attained in the Set-Up and Delivery section. Customer Service will want all this information for warranty purposes.



## ACCESSORIES

The following is a list of all the accessories that you can use with your Cal Spa Creative Wood Designs Gazebo. If you wish to order an accessory, feel free to contact your dealer with the desired part name and part number, or visit [www.calspas.com](http://www.calspas.com).

<b>Description</b>	<b>Size</b>	<b>Wood</b>	<b>Part Number</b>	
			<b>Cal Stone</b>	<b>Deluxe Stone</b>
Bar Top	11'	WOOD289	WOOD289CS	WOOD289DS
	80'	WOOD288	WOOD288CS	WOOD288DS
	75'	WOOD287	WOOD287CS	WOOD287DS
Round Corner		WOOD199	WOOD199CS	WOOD199DS
Storage Bench	11'	WOOD905	WOOD905CS	WOOD905DS
	80'	WOOD902	WOOD902CS	WOOD902DS
	75'	WOOD901	WOOD901CS	WOOD901DS
Crescent S/B		WOOD900	WOOD900CS	WOOD900DS
Bar Corbel		WOO270405060		
Bench Leg		WOO27405020		
Bar Stool		WOOD127	WOOD127CS	WOOD127DS
Surround Step	11'	WOOD296		
	80'	WOOD297		
	75'	WOOD298		
Crescent Step		WOOD214		
30' Step		WOOD107		
30" Storage Step w/Box		WOOD133		
5' Step		WOOD109		
5' Step Storage w/Box		WOOD134		
30" Step w/Handrail		WOOD107-2		
Round Planter		WOOD101		
Square Planter		WOOD100		
Crown Planter		WOOD189		
Octagon Planter		WOOD148		
Crescent Planter		WOOD168		
Bench	11'	WOOD923	WOOD923CS	WOOD923DS
	80'	WOOD922	WOOD922CS	WOOD922DS
	75'	WOOD921	WOOD921CS	WOOD921DS
Crescent Bench		WOOD920	WOOD920CS	WOOD920DS
Privacy Panel		WOOD183		
30" Step (3 tier)	30"	WOOD108		
30" Step (3 Tier with Handrail)	30"	WOOD108-2		
Towel/Wine Glass Rack	4'	WOOD113		
Towel/Wine Glass Rack	5'	WOOD113-5		
Wine Glass Hanger		WOOD114		
Towel Tree		WOOD169		
Kidzone Playhouse		KDZ100		

## PARTS LIST

### 12' - 12' Plexi Wall Solid Roof - Octagon

Item Number	Description	Part Number	Quantity
1	6' Lattice Wall Panel (Low)	WOO27105860	7
2	6' Lattice Door Panel	WOO27105840	1
3	2"x64"x18' Solid Octagon Roof Panel	WOO27206980	8
4	115" Rafter (12' Octagon)	WOO27208160	8
5	2"x2"x82 1/2" Corner Connector	WOO27106840	8
6	10' Octagon Top Center	WOO27211480	1
7	2"x4"x107" Crown Molding	WOO27208200	8
8	8x2 1/2" Screw SQ Drive Drywall	HAR13201150	80
9	8x3" SQ Drive Drywall	HAR13201140	15

**12' - 16' Plexi Wall Metal Roof**

<b>Item Number</b>	<b>Description</b>	<b>Part Number</b>	<b>Quantity</b>
1	4' Luxury Wall Panel - Complete	WOO27102560	6
2	5' Luxury Door - Complete	WOO27107460	1
3	4"x4"x84" Corner Connector	WOO27106080	4
4	2"x4"x43" Jack Rafter (L)	WOO27200660	4
5	2"x4"x67" Jack Rafter (R), No Slider	WOO27200620	4
6	2"x4"x43" Jack Rafter (R)	WOO27200580	4
7	2"x4"x67" Jack Rafter (L), No Slider	WOO27200640	4
8	2"x4"x67" Common Rafter STD, No Slider	WOO27200480	8
9	2"x4"x46 1/2" B&BTR M1	WOO27208720	2
10	2"x4"x45" Center	WOO27210560	1
11	2"x4"x94 1/2" M1	WOO27208460	2
12	89" Hip Rafter STD, No Slider	WOO27200460	4
13	2"x3"x72" Header Boards	WOO27107700	4
14	2"x3"x96" Header Boards	WOO27107720	4
15	2"x4"x6 1/2" Corner Stabilizer M2	WOO27200600	4
16	2"x2"x24" M2	WOO27106900	4
17	1"x4"x18" M2 Cross Ties	WOO27209180	6
18	2"x4"x60 Cross Ties M1	WOO27200140	6
19	82 3/4" Crown Molding	HAR13900190	8
20	62" Crown Molding	HAR13900170	6
21	#9 Center Metal Panel Top	WOO27200980	2
22	#9 Center Metal Panel Bottom	WOO27201000	2
23	#7 Metal Roof Panel Top (L)	WOO27200820	4
24	#7 Metal Roof Panel Bottom (L)	WOO27200840	4
25	#7 Metal Roof Panel Top (R)	WOO27200860	4
26	#7 Metal Roof Panel Bottom (R)	WOO27200880	4
27	Coil Strap	HAR13900070	6
28	8x2 1/2" Screw SQ Drive Drywall	HAR13201150	150
29	8x3" Screw SQ Drive Drywall	HAR13201140	25
30	Dome Bracket	HAR13800020	6
31	8x1 1/2" Molding Screw	HAR13200050	40
32	8x1" Metal Roof Screw	HAR13200200	100
33	3' Luxury Wall Panel	WOO27102570	1

---

# NOTES

\$5.00



# 2004 Owner's Manual

## LUXURY GAZEBO

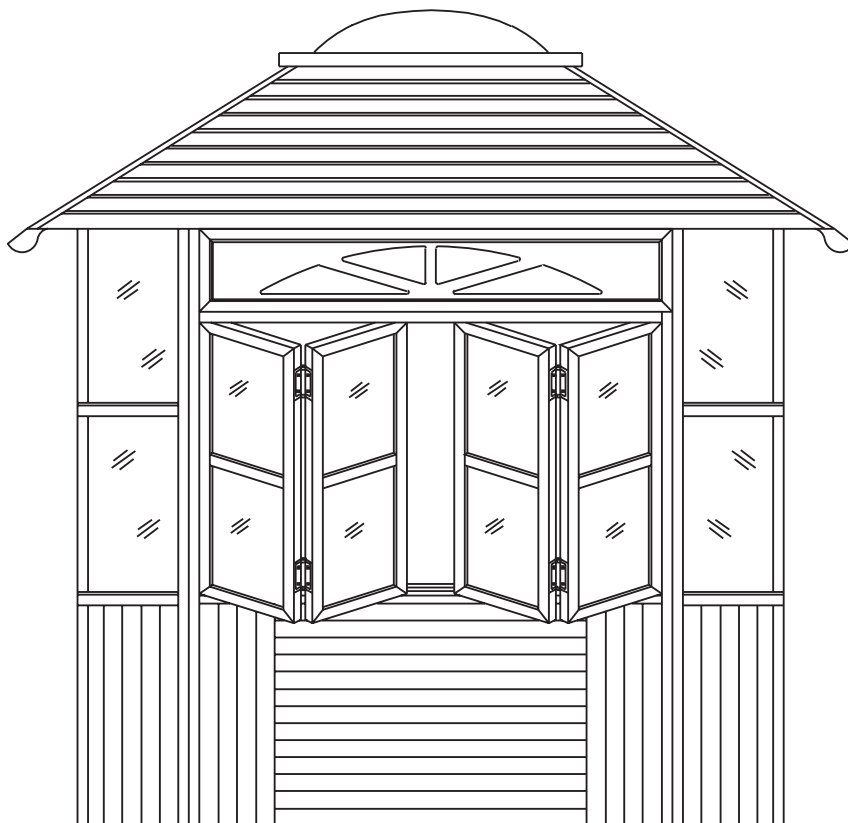

Duplication without written consent is strictly prohibited.

This Owner's Manual is for gazebos manufactured after January 1, 2004

Due to continuous improvement programs, all models, operation, and/or specifications are subject to change without prior notice.

LTR17000777

# Table of Contents

- Benefits of Owning a Gazebo .....2
- Safety Instructions .....3
- Contact Information.....4
- Warranty Information .....4
- Set-up and Delivery .....5
- Assembly .....9
- Cleaning, Maintenance and Troubleshooting .....14
- Appendix .....15
  - Accessories .....16
  - Parts List.....17
  - Notes.....19

### BENEFITS OF OWNING A GAZEBO

Owning a gazebo allows you to have a wonderful place to unwind after a long day of work. It offers a place for you to socialize with family and friends. It offers great cover in the event that you purchase a bar-b-que and/or spa. Owning a gazebo can add character to your patio and/or yard. You can use a gazebo for whatever best suits your needs.

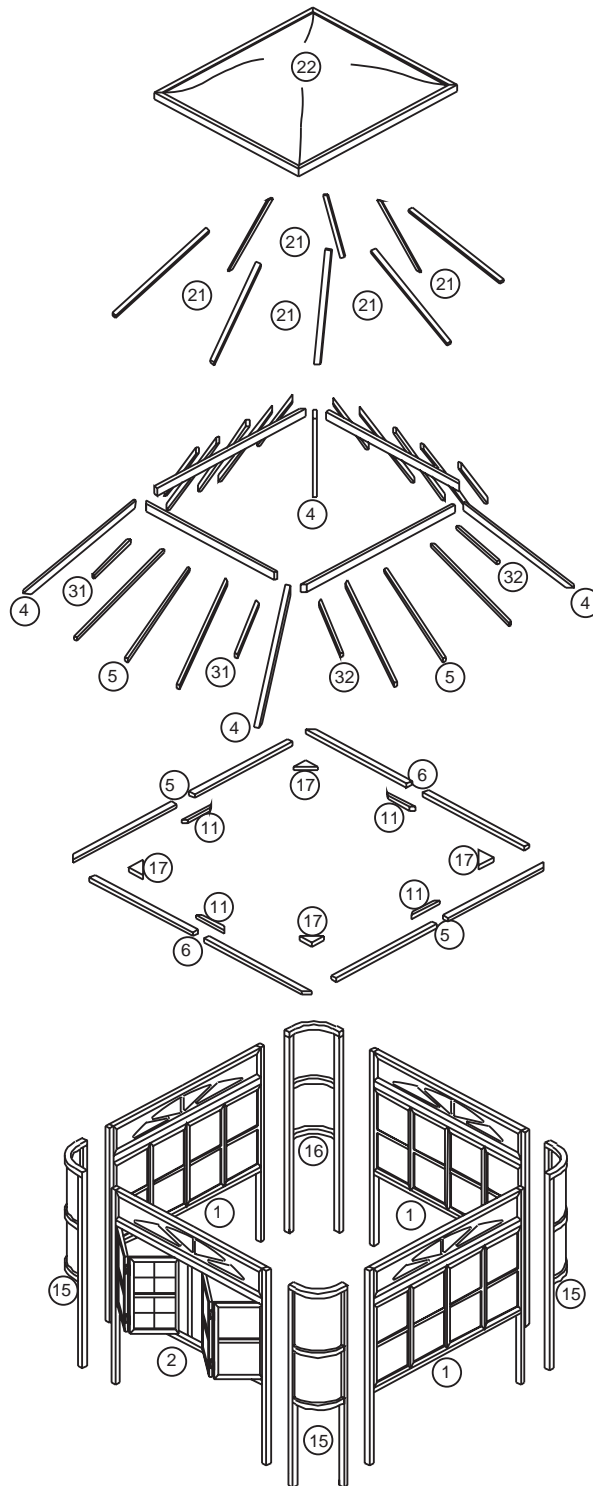

**Figure 1. Luxury Gazebo**

**NOTE:** Each item number listed above can be found in the “Parts List” section of this manual.

## **SAFETY INSTRUCTIONS**

### **Carefully read and follow all safety instructions.**

1. When installing and assembling your gazebo, it is recommended that 2 or more people be involved.
2. Do not use the unit during an electrical storm. as there is a remote chance of getting struck by lightening.
3. Do not climb on top of the gazebo. While the gazebo is made out of high-quality wood and is extremely durable, the gazebo is not meant to be used as a jungle gym. Thus, falling off of the gazebo while climbing on it can result in serious injury, possibly even death.
4. Do not attempt any repair without consulting the manufacturer first. Unauthorized repair attempts will void the manufacturer's warranty.

**Save this information.**



## CONTACT INFORMATION

For customer service, please contact your authorized dealer immediately. If you need additional information and/or assistance, please contact:

C.A.I. Customer Service Department  
1462 East Ninth Street  
Pomona, CA 91766  
Toll Free: 1-800-CAL-SPAS  
Fax: 1-909-629-3890

## WARRANTY INFORMATION

See your Cal Spas Creative Wood Designs dealer for a copy of the applicable warranty, details and any questions you may have regarding the warranty coverage on your gazebo.

### Warranty Limitations

The Limited Warranty is void if the gazebo has been subject to negligence, alteration, misuse, abuse, repairs by non- C.A.I. authorized representatives, acts of God and any other cases beyond the control of C.A.I. Examples of common acts invalidating this warranty include but are not limited to:

Use of the gazebo in a non-residential application.

Scratches caused by normal use.

Damage caused by extreme weather conditions. (hot, cold, etc.)

Damage caused by dirt, sand, and/or water damage.

Damage caused by continuous operation of the gazebo with either known or unknown problems.

Damage caused by direct sunlight.

Damage caused as a result of failure to follow the assembly instructions as defined in this Owner's Manual.

This Limited Warranty applies only to gazebos normally used for personal, family, or household purposes.

This Limited Warranty specifically excludes commercial gazebos.

### Warranty Exclusions

C.A.I. warrants the gazebo from defects in material and workmanship for a period of 90 days from the original date of purchase.

## DELIVERY AND SET-UP

Please make a record of the following. It will be valuable if service is required.

Gazebo Model: \_\_\_\_\_

Gazebo Serial Number: \_\_\_\_\_

Date Purchased: \_\_\_\_\_

Date Installed: \_\_\_\_\_

Gazebo Dealer's Phone Number: \_\_\_\_\_

Gazebo Dealer's Address: \_\_\_\_\_

Most cities and counties require permits for exterior construction and electrical circuits. In addition, some communities have codes requiring residential barriers such as fencing and/or self-closing gates on property to prevent unsupervised access to the property by children under the age of 5. Your dealer can provide information on which permits may be required and how to obtain them prior to the delivery of your equipment.

### PLANNING THE BEST LOCATION FOR YOUR GAZEBO

Here are some of the things that you will need to consider when determining where to locate your new gazebo.

#### How Will You Use Your Gazebo?

How you intend to use your gazebo will help you determine where you should position it. For example, will you use your gazebo for recreational purposes? If your gazebo is mainly used for family functions, be sure to leave plenty of room around it for activity. In any case dealing in how it is to be used, you'll probably want to create a specific mood around it.

#### Consider Your Privacy

In a cold-weather climate, bare trees won't provide much privacy. Think of your gazebo's surroundings during all seasons to determine your best privacy options. Consider the view of your neighbors as well, when you plan the location of your gazebo.

#### Provide A View With Your Gazebo

Think about the direction you will be facing when sitting in your gazebo. Do you have a special landscaped area in your yard that you find enjoyable? Perhaps there is an area that catches a soothing breeze during the day and lovely sunset in the evening. Consider these things when you plan your location.

## PREPARING A GOOD FOUNDATION

Your gazebo needs a solid and level foundation. The area that it sits on must be able to support the weight of the gazebo and the occupants who use it. If the foundation is inadequate, it may shift or settle after the gazebo is in place, causing stress that could alter the structure's figure and possibly split the wooden joints.

**NOTE:** Damage caused by inadequate or improper foundation support is not covered by the warranty. It is the responsibility of the gazebo owner to provide a proper foundation for the gazebo.

Place the gazebo on an elevated foundation (preferably a 3" concrete slab).

\* If you are installing your gazebo on an elevated wood deck or other structure, it is highly recommended that you consult a structural engineer or contractor to ensure the structure will support the weight.

\* It is strongly recommended that a qualified, licensed contractor prepare the foundation for your gazebo.

## Your Cal Spas Creative Wood Designs Retailer Can Help You With Foundations And More

Your retailer has a wealth of information and experience about how to get the most out of your gazebo. Your gazebo retailer also has a full line of accessories that are engineered to compliment your gazebo.

**NOTE:** It is strongly advised that you have a licensed professional install the foundation for your new gazebo. It is imperative that the foundation is level, as any damage that occurs due to an uneven foundation is not covered by the warranty.

## Size Specifications

<u>Model</u>	<u>Length</u>	<u>Width</u>
Frontier Gazebo	8'	8'
	10'	8'
	12'	8'
Cottage Gazebo	8'	8'
Cabana Gazebo	7'	7'
	7.5'	7.5'
	8'	8'
Northeast Gazebo	7.5'	7.5'
	8'	8'
Lattice Wall Gazebo	7'	7'
	7.5'	7.5'
	8'	8'
	12'	8'
	16'	8'
	10'	10'
	12'	10'
	16'	10'
12'	12'	

<u>Model</u>	<u>Length</u>	<u>Width</u>
Lattice Wall Gazebo	12'	12'
(cont.)	16'	12'
	10' (Octagon)	10'
	12' (Octagon)	12'
Plexi Wall Gazebo	7'	7'
	7.5'	7.5'
	8'	8'
	12'	8'
	16'	8'
	10'	10'
	12'	10'
	12'	12'
	16'	12'
	10' (Octagon)	10'
	12' (Octagon)	12'
	15' (Octagon)	15'
	18' (Octagon)	18'
<b>Luxury Wall Gazebo</b>	<b>7'</b>	<b>7'</b>
	<b>7.5'</b>	<b>7.5'</b>
	<b>8'</b>	<b>8'</b>
	<b>12'</b>	<b>8'</b>
	<b>16'</b>	<b>8'</b>
	<b>10'</b>	<b>10'</b>
	<b>12'</b>	<b>10'</b>
	<b>16'</b>	<b>10'</b>
	<b>12'</b>	<b>12'</b>
	<b>16'</b>	<b>12'</b>
Savannah Wall Gazebo	12'	8'
	10'	10'
	12'	10'
	16'	10'
	12'	12'
	16'	12'
	10' (Octagon)	10'
	12' (Octagon)	12'
	15' (Octagon)	15'
	18' (Octagon)	18'
Timberline Gazebo	12'	8'
	10'	10'
	12'	10'
	12'	12'
	16'	12'

<b>Model</b>	<b>Length</b>	<b>Width</b>
Lighthouse Gazebo	10'	10'
	12'	10'
	12'	12'
	16'	12'
Plantation Gazebo	10'	10'
	12'	10'
	12'	12'
	16'	12'
Chalet Gazebo	12'(Octagon)	12'
	14'(Octagon)	14'
	16'(Octagon)	16'
Victorian Gazebo	12'(Octagon)	12'
	14' (Octagon)	14'
	16' (Octagon)	16'

**NOTE:** The gazebo above that is listed in bold lettering is the gazebo that you purchased.

**NOTE:** For all gazebos, regardless of model, it is recommended that the foundation (concrete slab, railroad ties or pre-cast stepping stones) extend beyond the dimension of the gazebo. For example, if the gazebo you purchased is 12'x12', you will want your foundation to be 12.5'x12.5'. The reason for this is because it will be easier to maintain the area around the gazebo (mowing the lawn, edging, etc.) without damaging or scarring the gazebo. Also, in doing this, you will eliminate any potential problems, foundation-wise, in the future.

**NOTE:** This Owner's Manual applies to the various sizes that are included in the Luxury Gazebo line (7'x7', 7.5'x7.5', 8'x8', 8'x12', 8'x12', 8'x16', 10'x10', 10'x16', 10'x12', 12'x12' and 12'x16'). While the sizes will vary from gazebo to gazebo, the assembly instructions will be the same, unless otherwise noted.

**Tools and Materials**

- |                           |                                      |
|---------------------------|--------------------------------------|
| Utility Knife             | 25' Tape Measure                     |
| Cordless Drill            | 100' Extension Cord                  |
| 1/8" Pilot Hole Drill Bit | 1/2" Ratchet and Impact Drill        |
| Electric Drill            | 9/16" Socket                         |
| Phillips-Head Drill Tips  | 1/2" Carbide Drill Bit (Masonry Bit) |
| Slotted-Head Drill Tips   | Sandpaper (Various Grades)           |
| Redwood Stain             | Wood Putty                           |
| Gray Wash Stain           | Rags                                 |

# Assembly Instructions

The following sections will tell you how to assembly your gazebo. If you have any questions, problems with material and/or parts, please contact your local retailer.

(A)

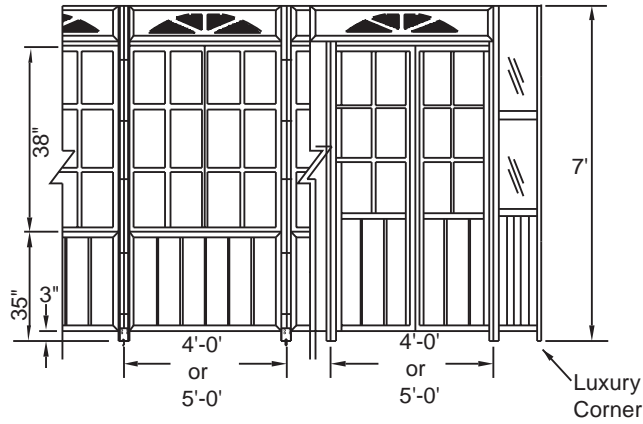

## Wall Panel Assembly

**NOTE:** Please follow the written steps in conjunction with the figures that are shown.

1. Stand two panels up side by side. Attach the panels together using 5 drywall screws (**Figure 2A**).
2. Repeat this step until all the panels are attached. **Figure 2B** will show you which order to go in.

**NOTE:** The rounded corners attach to the wall panels the same way, with 5 drywall screws. The owner must use care when securing the wall panel and rounded corner together, as any damage incurred during assembly is not covered by the warranty.

(B)

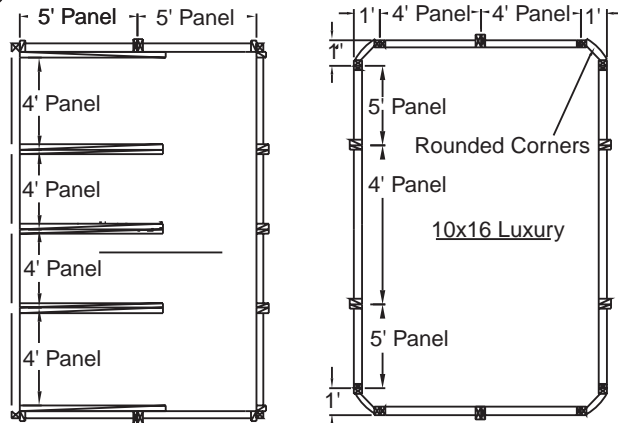

**NOTE:** Use care when attaching the sides and corners. Be sure that the windows do not come in contact with the mounting screws.

**Figure 2** Wall Panel Assembly

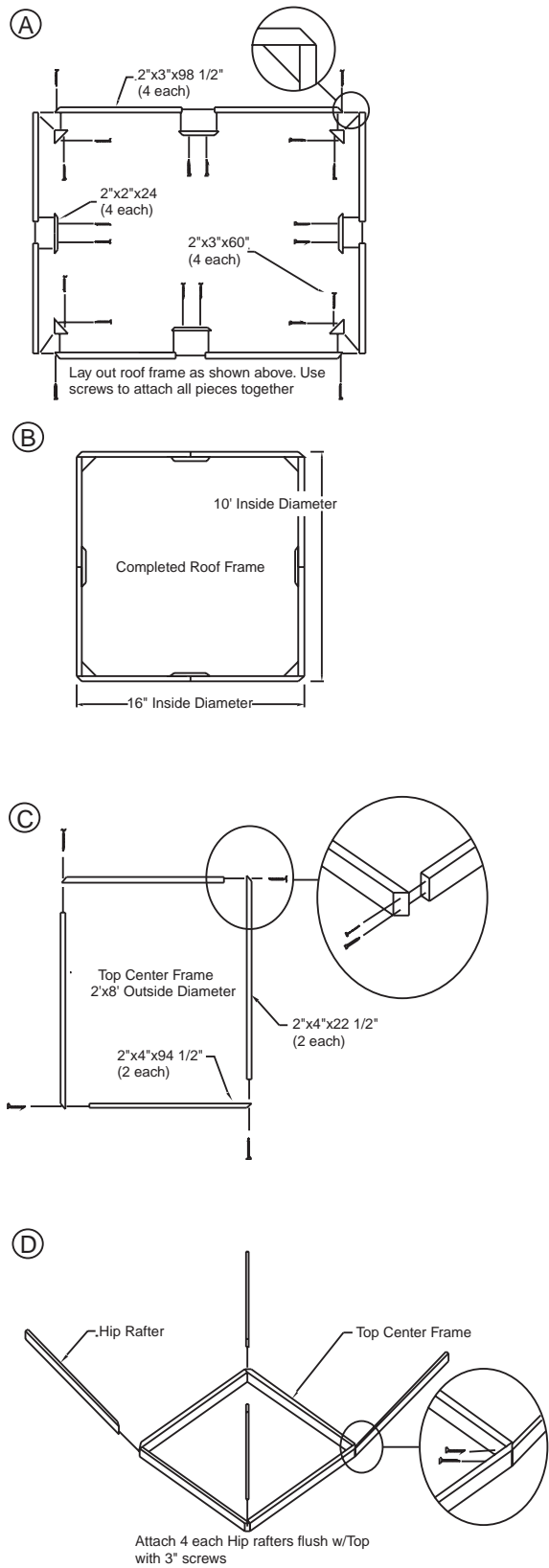

### Roof Frame Assembly

When assembling the roof frame, it is recommended that you lay everything out and assemble it on a flat surface. The owner should also note that there are different sizes in the Luxury line of gazebos. These directions are generalized, relating to measurements.

**NOTE:** Check the parts list that came with your gazebo and make sure that all the parts are present. Also, please follow the written steps in conjunction with the figures that are shown.

1. Take four 2"x4"x98 1/2" pieces of wood and lay them out on the ground (**Figure 3A**), in effect making a square.
2. Place corner stabilizers (4 each) and attach in each corner using drywall screws. Attach 2"x2"x24" splice (4 each) at each center joint. This will reinforce the roof frame (**Figure 3A**).
3. Use the provided drywall screws to attach all the pieces together (**Figure 3B**).
4. Attach each corner together with the provided screws, making sure to keep the 45° corners pointing outward (**Figure 3C - inset**). This is the top center frame.
5. Take the hip rafters (4 each) and attach them to each corner of the top center frame. Make sure that the 45° corner matches the 45° end on the hip rafters (**Figure 3D**).

Figure 3. Roof Frame Assembly

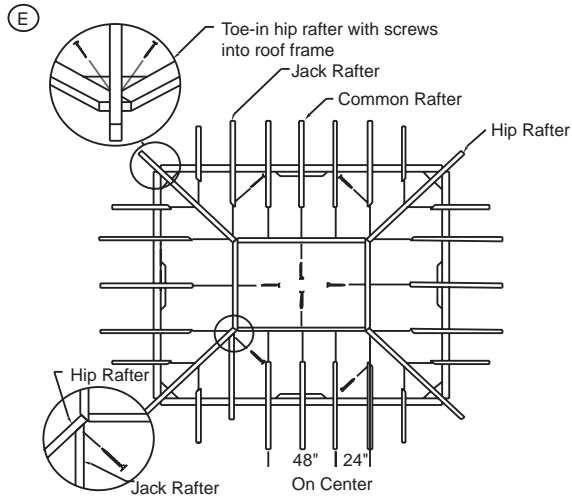

6. Take 4 common rafters and attach them to the middle of each side of the top center frame assembly (**Figure 3E**). Use the toe-in method (**see inset**).
7. With the common rafters now installed, attach the the remaining jack rafters using the toe-in method. Make sure that each jack rafter is spaced evenly apart. This will ensure sufficient anchoring points for the roof panels.
8. **Figure 3F** shows what the roof frame will look like when it is completed.

**NOTE:** It is recommended that you have an assistant for the following step.

9. Place the assembled roof section on top of the wall panel assembly. Anchor the roof section by using drywall screws (**Figure 3G**).

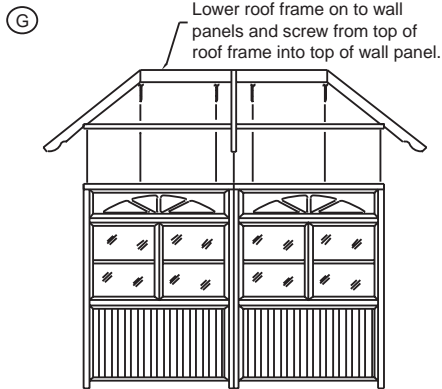
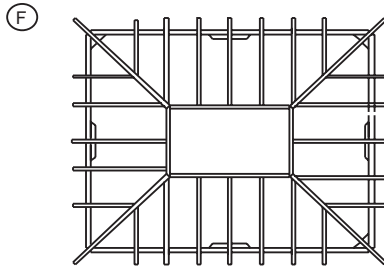

**Figure 3. Roof Frame Assembly**



## Roof Panel Installation

**NOTE:** It is strongly recommended that you use a ladder for the final steps of the gazebo assembly.

1. Prior to installing the roof panels, a center line must be drawn on the top side of each rafter (**Figure 4A**).
2. Place each roof panel in place (with the edge being flush with the center line) and mount using drywall screws (**Figure 4B**).
3. Using the provided hardware, mount the dome bracket (**Figure 4C**).
4. Use 1 1/2" drywall screws to mount all ridge caps (**Figure 4C**).
5. Set the roof assembly onto the wall panel assembly and attach using drywall screws.

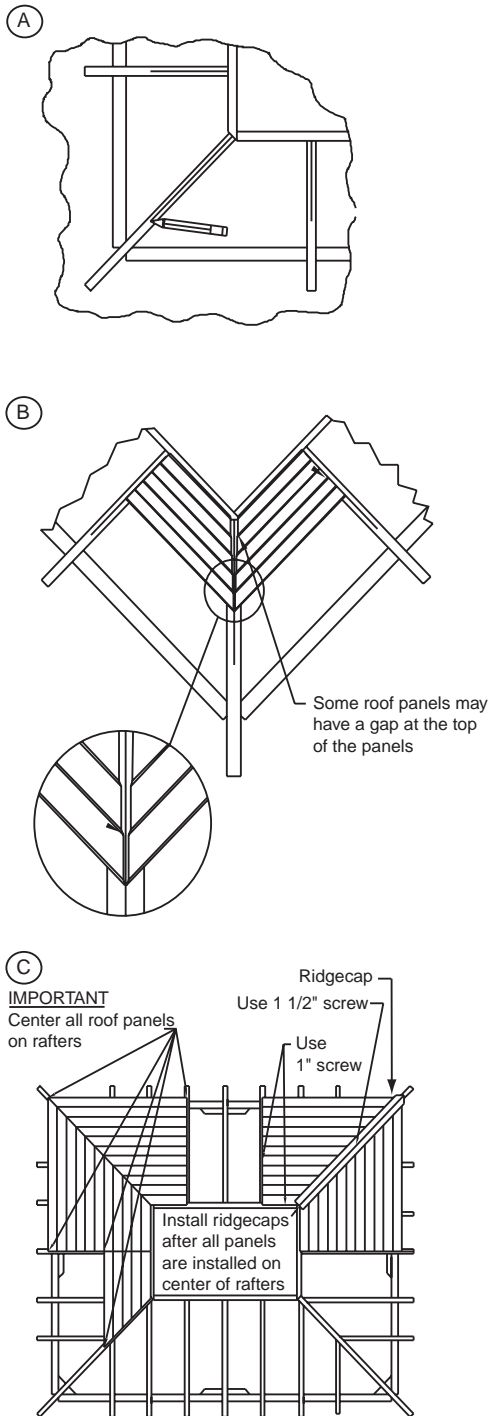

**Figure 4. Roof Panel Installation**

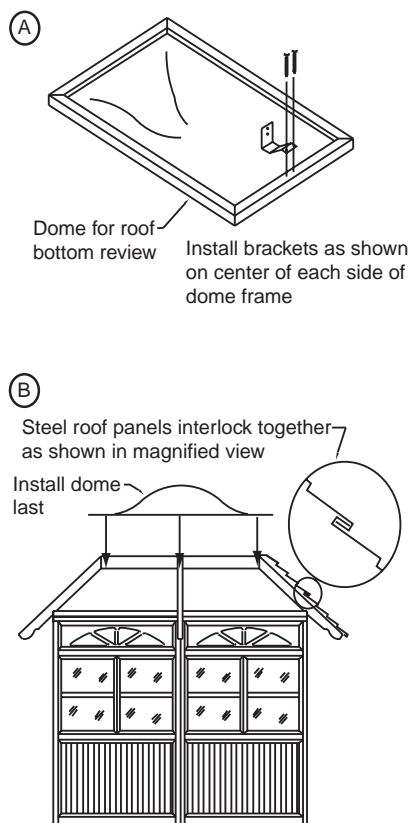

### Dome Installation

**NOTE:** The final steps of the gazebo assembly will require the use of a ladder.

1. Set the dome light assembly into the dome housing (**Figure 5A**).
2. From the inside the gazebo secure the dome assembly to the roof assembly using the dome brackets and drywall screws (**Figure 5B**). There will be four dome brackets that will connect to each side of the dome frame.

**Figure 5.** Dome Installation

## CLEANING, MAINTENANCE AND TROUBLESHOOTING

### Cleaning

Your gazebo was designed with low cleaning and maintenance in mind. We recommend that the gazebo be cleaned at least twice a month (or more, if needed). When cleaning your gazebo, cleaning solvents are not recommended. Using a sponge and water will be fine. For ground-in dirt and grime, please refer to the following section.

### Maintenance

Maintaining your gazebo will be an easy task. We recommend that every six months you should do an inspection of the wood on your gazebo. Take note of any deformities in the wood (i.e. cracking, peeling, dirt, grime, etc.). It is recommended that you spot sand these areas with 120-grit sandpaper. When complete, wipe these areas clean with a damp rag.

When dry, you must apply a coat of stain to the sanded area. Wipe the stained area clean and reapply until the sanded area matches the rest of the gazebo.

**NOTE:** An 8oz. can of stain will be supplied with each gazebo. To replace the can of stain, please contact your local Cal Enclosures dealer.

**NOTE:** On models that have plexi-glass windows, the use of a cheese cloth and warm water should be used. These windows are made of plexi-glass and do not hold up well under the abrasive conditions that many commercial cleaners generate.

## TROUBLESHOOTING PROCEDURES

**Q: Why will the windows on the gazebo not stay open/closed?**

**A:** This is most likely due to the fact that your foundation is not level. Foundations will most likely have a 1/4" pitch for drainage reasons. To rectify this problem, the gazebo must be shimmed on the low side. Using a standard level, shim the low side so that the gazebo is level.

**Q: Why won't the roof panels not sit correctly on the roof frame?**

**A:** Check the top plate on the top center frame and make sure it is level and installed correctly.

**Q: My roof and wall panels are lining up correctly and there are small gaps in the joint seams. Why is this?**

**A:** The main support post is not "plumb" (meaning vertically level). You must go back and make sure that the main support post is plumb. Also, you must make sure that each of your main support beams is "square" in relation to the main support post (meaning that there is a 90° angle when the main support post and the main support beam intersect).

---

## APPENDIX

The items that will be covered in this section will consist of the following:

Accessories

Part Numbers

Notes

In order for your retailer to expedite your order, for parts and accessories, it is recommended that you have the information that you attained in the Set-Up and Delivery section. Customer Service will want all this information for warranty purposes.

## ACCESSORIES

The following is a list of all the accessories that you can use with your Cal Spa Creative Wood Designs Gazebo. If you wish to order an accessory, feel free to contact your dealer with the desired part name and part number, or visit [www.calspas.com](http://www.calspas.com).

<u>Description</u>	<u>Size</u>	<u>Wood</u>	<u>Part Number</u>	
			<u>Cal Stone</u>	<u>Deluxe Stone</u>
Bar Top	11'	WOOD289	WOOD289CS	WOOD289DS
	80'	WOOD288	WOOD288CS	WOOD288DS
	75'	WOOD287	WOOD287CS	WOOD287DS
Round Corner		WOOD199	WOOD199CS	WOOD199DS
Storage Bench	11'	WOOD905	WOOD905CS	WOOD905DS
	80'	WOOD902	WOOD902CS	WOOD902DS
	75'	WOOD901	WOOD901CS	WOOD901DS
Crescent S/B		WOOD900	WOOD900CS	WOOD900DS
Bar Corbel		WOO270405060		
Bench Leg		WOO27405020		
Bar Stool		WOOD127	WOOD127CS	WOOD127DS
Surround Step	11'	WOOD296		
	80'	WOOD297		
	75'	WOOD298		
Crescent Step		WOOD214		
30' Step		WOOD107		
30" Storage Step w/Box		WOOD133		
5' Step		WOOD109		
5' Step Storage w/Box		WOOD134		
30" Step w/Handrail		WOOD107-2		
Round Planter		WOOD101		
Square Planter		WOOD100		
Crown Planter		WOOD189		
Octagon Planter		WOOD148		
Crescent Planter		WOOD168		
Bench	11'	WOOD923	WOOD923CS	WOOD923DS
	80'	WOOD922	WOOD922CS	WOOD922DS
	75'	WOOD921	WOOD921CS	WOOD921DS
Crescent Bench		WOOD920	WOOD920CS	WOOD920DS
Privacy Panel		WOOD183		
30" Step (3 tier)	30"	WOOD108		
30" Step (3 Tier with Handrail)	30"	WOOD108-2		
Towel/Wine Glass Rack	4'	WOOD113		
Towel/Wine Glass Rack	5'	WOOD113-5		
Wine Glass Hanger		WOOD114		
Towel Tree		WOOD169		
Kidzone Playhouse		KDZ100		

**PARTS LIST****12'x16' Luxury Gazebo - Solid Roof**

<b><u>Item Number</u></b>	<b><u>Description</u></b>	<b><u>Part Number</u></b>	<b><u>Quantity</u></b>
1	5' Luxury Wall Panel - Complete	WOO27102920	7
2	5' Luxury Door - Complete	WOO27107460	1
3	4' Luxury Wall Panel - Complete	WOO27102560	2
4	89" Hip Rafter	WOO27207640	4
5	2"x4"x67" Common Rafter - STD	WOO27207940	6
6	2"x3"x72" Header Boards	WOO27107700	4
7	2"x3"x96" Header Boards	WOO27107720	4
8	2"x2"x24 M2	WOO27106900	4
9	2"x4"x6 1/2" M2	WOO27200600	4
10	2"x4"x60" Cross Ties M1	WOO27200140	4
11	1"x4"x18" M2 Cross Ties	WOO27209180	4
12	2"x4"x94 1/2" M1	WOO27208460	2
13	2"x4"x46 1/2" Moon Roof Frame M1	WOO27208720	2
14	2"x4"x45" Center Support	WOO27210580	1
15	Luxury Round Corner	WOO27105940	3
16	Luxury Round Corner - Spa Side	WOO27105980	1
17	62"x77 1/2"x6' Solid Roof Panel (L)	WOO27203900	4
18	62"x77 1/2"x6' Solid Roof Panel (R)	WOO27203680	4
19	46 1/2"x62" Center Solid Wood Panel	WOO27204240	2
20	2"x4"x79" Crown Molding	WOO27208260	4
21	2"x4"x60" Crown Molding	WOO27208300	6
22	54"x102" Dome w/ Frame	WOO27211800	1
23	Dome Bracket	HAR13800020	6
24	8x2 1/2" Screw SQ Drive Drwall	HAR13201150	125
25	Screw 8x3" DQ Drive Drywall	HAR13201140	25
26	Coil Strap	HAR13900070	4
27	6x1 1/4" Square Drive Type	HAR13200420	25
28	8x1" Screw for Metal Roof	HAR13200200	40

**12'x16' Luxury Gazebo - Metal Roof**

<b>Item Number</b>	<b>Description</b>	<b>Part Number</b>	<b>Quantity</b>
1	5' Luxury Wall Panel - Complete	WOO27102920	7
2	5' Luxury Door - Complete	WOO27107460	1
3	4' Luxury Wall Panel - Complete	WOO27102560	2
4	#7 Metal Roof (R) Bottom	WOO27200880	4
5	#7 Metal Roof (R) Top	WOO27200860	4
6	#7 Metal Roof (L) Top	WOO27200820	4
7	#7 Metal Roof (L) Bottom	WOO27200840	4
8	#9 Metal Roof Top	WOO27200980	2
9	#9 Metal Roof Bottom	WOO27201000	2
10	89" Hip Rafter STD, No Slider	WOO27200460	4
11	2"x4"x94 1/2" M1	WOO27208460	2
12	2"x3"x72 Header Boards Top of Wall	WOO27107700	4
13	2"x4"x67" Common Rafter, No Slider	WOO27200480	8
14	2"x4"x46 1/2" B&BTR M1 Moon Roof	WOO27208720	2
15	2"x4"x60" Cross Ties M1	WOO27200140	4
16	2"x3"x96" Header Boards Top of Wall	WOO27107720	4
17	2"x4"x6 1/2" Corner Stabilizer M2	WOO27200600	4
18	1"x4"x18" M2 Cross Ties	WOO27209180	4
19	2"x4"x45" Center Support	WOO27210580	1
20	Luxury Round Corner	WOO27105940	3
21	Luxury Round Corner (Spa Side)	WOO27105980	1
22	Metal Crown Molding 82 3/2"	HAR13900190	4
23	62" Metal Crown Molding	HAR13900170	6
24	2"x2"x24" M2	WOO27106900	4
25	8x2 1/2" Screw SQ Drive Drywall	HAR13201150	125
26	8x3" SQ Drive Drywall	HAR13201140	25
27	Coil Strap	HAR13900070	4
28	6x1 1/4" Screw SQ Drive Drywall	HAR13200420	25
29	54"x102" Dome w/Frame	WOO27211800	1
30	2"x4"x67" Jack Rafter, No Slider (L)	WOO27200640	4
31	2"x4"x67" Jack Rafter, No Slider (R)	WOO27200620	4
32	2"x4"x43" Jack Rafter (L)	WOO27200660	4
33	2"x4"x43" Jack Rafter (R)	WOO27200580	4
34	Dome Bracket	HAR13800020	6
35	8x1 1/2" Molding Screw	HAR13200050	50
36	8x1" Roof Metal Screw	HAR13200200	120

---

**NOTES**



\$5.00



# 2004 Owner's Manual

## FRONTIER GAZEBO

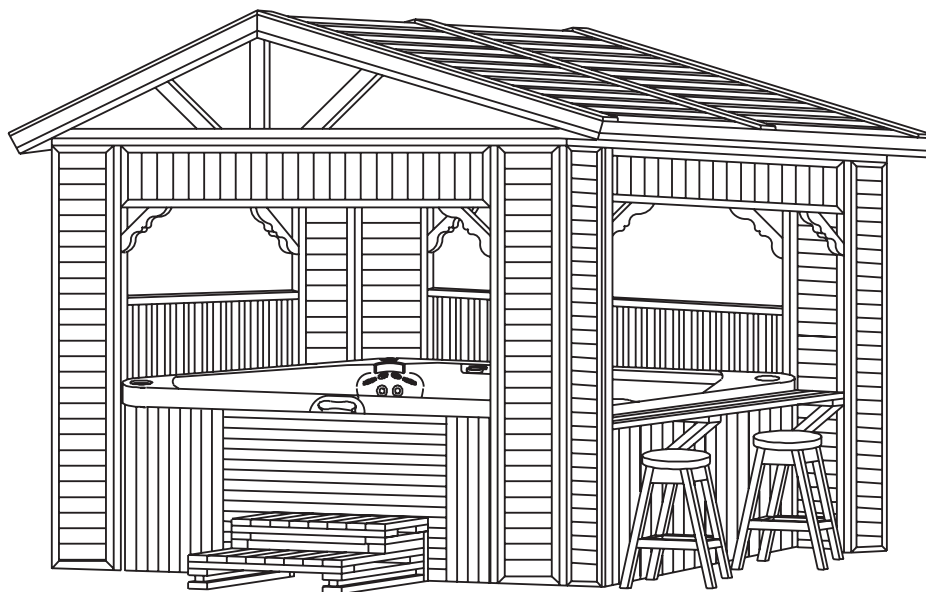

Duplication without written consent is strictly prohibited.

This Owner's Manual is for gazebos manufactured after January 1, 2004

Due to continuous improvement programs, all models, operation, and/or specifications are subject to change without prior notice.

LTR17000774

# Table of Contents

Benefits of Owning a Gazebo .....	2
Safety Instructions .....	3
Contact Information.....	4
Warranty Information .....	4
Set-up and Delivery .....	5
Assembly .....	9
Cleaning, Maintenance and Troubleshooting .....	11
Appendix .....	12
Accessories .....	13
Parts List.....	14
Notes.....	17

### BENEFITS OF OWNING A GAZEBO

Owning a gazebo allows you to have a wonderful place to unwind after a long day of work. It offers a place for you to socialize with family and friends. It offers great cover in the event that you purchase a bar-b-que and/or spa. Owning a gazebo can add character to your patio and/or yard. You can use a gazebo for whatever best suits your needs.

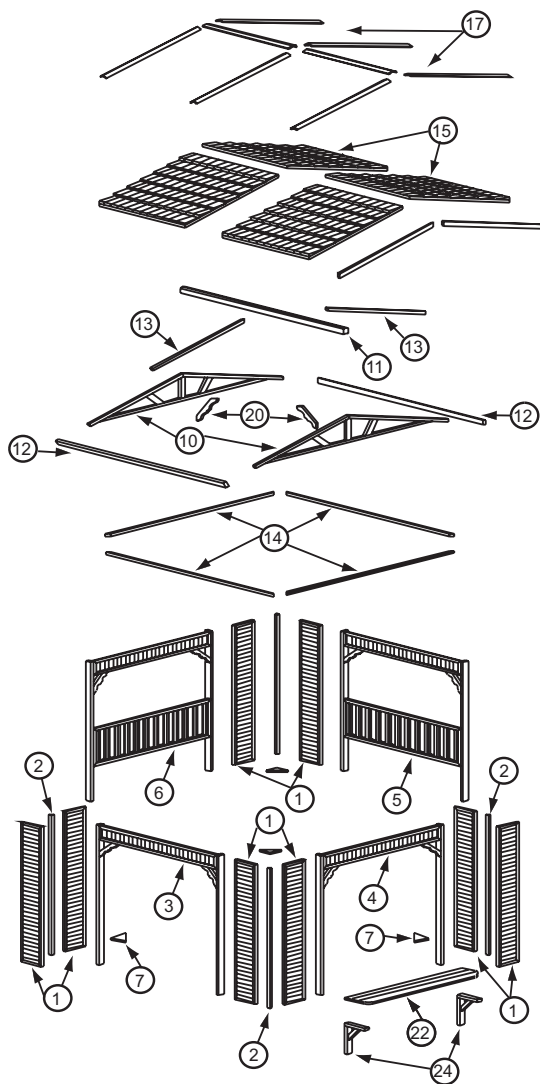

Figure 1. Frontier Gazebo (Octagon Series)

**NOTE:** The numbers in Figure 1 are located in the back of this manual, in the “Parts List” section.

## **SAFETY INSTRUCTIONS**

### **Carefully read and follow all safety instructions.**

1. When installing and assembling your gazebo, it is recommended that 2 or more people be involved.
2. Do not use the unit during an electrical storm, as there is a remote chance of getting struck by lightning.
3. Do not climb on top of the gazebo. While the gazebo is made out of high-quality wood and is extremely durable, the gazebo is not meant to be used as a jungle gym. Thus, falling off of the gazebo while climbing on it can result in serious injury, possibly even death.
4. Do not attempt any repair without consulting the manufacturer first. Unauthorized repair attempts will void the manufacturer's warranty.

**Save this information.**

## CONTACT INFORMATION

For customer service, please contact your authorized dealer immediately. If you need additional information and/or assistance, please contact:

C.A.I. Customer Service Department  
1462 East Ninth Street  
Pomona, CA 91766  
Toll Free: 1-800-CAL-SPAS  
Fax: 1-909-629-3890

## WARRANTY INFORMATION

See your Cal Spas Creative Wood Designs dealer for a copy of the applicable warranty, details and any questions you may have regarding the warranty coverage on your gazebo.

### Warranty Limitations

The Limited Warranty is void if the gazebo has been subject to negligence, alteration, misuse, abuse, repairs by non- C.A.I. authorized representatives, acts of God and any other cases beyond the control of C.A.I. Examples of common acts invalidating this warranty include but are not limited to:

Use of the gazebo in a non-residential application.

Scratches caused by normal use.

Damage caused by extreme weather conditions. (hot, cold, etc.)

Damage caused by dirt, sand, and/or water damage.

Damage caused by continuous operation of the gazebo with either known or unknown problems.

Damage caused by direct sunlight.

Damage caused as a result of failure to follow the assembly instructions as defined in this Owner's Manual.

This Limited Warranty applies only to gazebos normally used for personal, family, or household purposes.

This Limited Warranty specifically excludes commercial gazebos.

### Warranty Exclusions

C.A.I. warrants the gazebo from defects in material and workmanship for a period of 90 days from the original date of purchase.

**REMINDER: PLEASE DO NOT FORGET TO REGISTER YOUR NEW PRODUCT AT [WWW.CALSPAS.COM](http://WWW.CALSPAS.COM)**

## DELIVERY AND SET-UP

Please make a record of the following. It will be valuable if service or replacement parts are required.

Gazebo Model: \_\_\_\_\_

Gazebo Serial Number: \_\_\_\_\_

Date Purchased: \_\_\_\_\_

Date Installed: \_\_\_\_\_

Gazebo Dealer's Phone Number: \_\_\_\_\_

Gazebo Dealer's Address: \_\_\_\_\_

Most cities and counties require permits for exterior construction and electrical circuits. In addition, some communities have codes requiring residential barriers such as fencing and/or self-closing gates on property to prevent unsupervised access to the property by children under the age of 5. Your dealer can provide information on which permits may be required and how to obtain them prior to the delivery of your equipment.

## PLANNING THE BEST LOCATION FOR YOUR GAZEBO

Here are some of the things that you will need to consider when determining where to locate your new gazebo.

### How Will You Use Your Gazebo?

How you intend to use your gazebo will help you determine where you should position it. For example, will you use your gazebo for recreational purposes? If your gazebo is mainly used for family functions, be sure to leave plenty of room around it for activity. In any case dealing in how it is to be used, you'll probably want to create a specific mood around it.

### Consider Your Privacy

In a cold weather climate, bare trees won't provide much privacy. Think of your gazebos surroundings during all seasons to determine your best privacy options. Consider the view of your neighbors as well, when you plan the location of your gazebo.

### Provide A View With Your Gazebo

Think about the direction you will be facing when sitting in your gazebo. Do you have a special landscaped area in your yard that you find enjoyable? Perhaps there is an area that catches a soothing breeze during the day and lovely sunset in the evening. Consider these things when you plan your location.

## PREPARING A GOOD FOUNDATION

Your gazebo needs a solid and level foundation. The area that it sits on must be able to support the weight of the gazebo and the occupants who use it. If the foundation is inadequate, it may shift or settle after the gazebo is in place, causing stress that could alter the structures figure and possibly split the wooden joints.

**NOTE:** Damage caused by inadequate or improper foundation support is not covered by the warranty. It is the responsibility of the gazebo owner to provide a proper foundation for the gazebo.

Place the gazebo on an elevated foundation (preferably a 3” concrete slab).

\* If you are installing your gazebo on an elevated wood deck or other structure, it is highly recommended that you consult a structural engineer or contractor to ensure the structure will support the weight.

\* It is strongly recommended that a qualified, licensed contractor prepare the foundation for your gazebo.

## Your Cal Spas Creative Wood Designs Retailer Can Help You With Foundations And More

Your retailer has a wealth of information and experience about how to get the most out of your gazebo. Your gazebo retailer also has a full line of accessories that are engineered to compliment your gazebo.

**NOTE:** It is strongly advised that you have a licensed professional install the foundation for your new gazebo. It is imperative that the foundation is level, as any damage that occurs due to an uneven foundation is not covered by the warranty.

## Size Specifications

<u>Model</u>	<u>Length</u>	<u>Width</u>
Frontier Gazebo	8'	8'
	10'	8'
	12'	8'
Cottage Gazebo	8'	8'
Cabana Gazebo	7'	7'
	7.5'	7.5'
	8'	8'
Northeast Gazebo	7.5'	7.5'
	8'	8'
Lattice Wall Gazebo	7'	7'
	7.5'	7.5'
	8'	8'
	12'	8'
	16'	8'
	10'	10'
	12'	10'
	16'	10'
	12'	12'

<b><u>Model</u></b>	<b><u>Length</u></b>	<b><u>Width</u></b>
Lattice Wall Gazebo (cont.)	12'	12'
	16'	12'
	10' (Octagon)	10'
	12' (Octagon)	12'
Plexi Wall Gazebo	7'	7'
	7.5'	7.5'
	8'	8'
	12'	8'
	16'	8'
	10'	10'
	12'	10'
	12'	12'
	16'	12'
	10' (Octagon)	10'
	12' (Octagon)	12'
	15' (Octagon)	15'
18' (Octagon)	18'	
Luxury Wall Gazebo	7'	7'
	7.5'	7.5'
	8'	8'
	12'	8'
	16'	8'
	10'	10'
	12'	10'
	16'	10'
	12'	12'
	16'	12'
Savannah Wall Gazebo	12'	8'
	10'	10'
	12'	10'
	16'	10'
	12'	12'
	16'	12'
	10' (Octagon)	10'
	12' (Octagon)	12'
15' (Octagon)	15'	
18' (Octagon)	18'	
Timberline Gazebo	12'	8'
	10'	10'
	12'	10'
	12'	12'
	16'	12'



<b><u>Model</u></b>	<b><u>Length</u></b>	<b><u>Width</u></b>
Lighthouse Gazebo	10'	10'
	12'	10'
	12'	12'
	16'	12'
Plantation Gazebo	10'	10'
	12'	10'
	12'	12'
	16'	12'
Chalet Gazebo	12'(Octagon)	12'
	14'(Octagon)	14'
	16'(Octagon)	16'
Victorian Gazebo	12'(Octagon)	12'
	14' (Octagon)	14'
	16' (Octagon)	16'

**NOTE:** The gazebo above that is listed in bold lettering is the gazebo that you purchased.

**NOTE:** For all gazebos, regardless of model, it is recommended that the foundation (concrete slab, railroad ties or pre-cast stepping stones) extend beyond the dimension of the gazebo. For example, if the gazebo you purchased is 12'x12', you will want your foundation to be 12.5'x12.5'. The reason for this is because it will be easier to maintain the area around the gazebo (mowing the lawn, edging, etc.) without damaging or scarring the gazebo. Also, in doing this, you will eliminate any potential problems, foundation-wise, in the future.

**NOTE:** This Owner's Manual applies to the various sizes that are included in the Frontier Gazebo line (8'x8', 10'x8' and 12'x8'). While the sizes will vary from gazebo to gazebo, the assembly instructions will be the same, unless otherwise noted.

## Tools and Materials

Utility Knife	25' Tape Measure
Cordless Drill	100' Extension Cord
1/8" Pilot Hole Drill Bit	1/2" Ratchet and Impact Drill
Electric Drill	9/16" Socket
Phillips-Head Drill Tips	1/2" Carbide Drill Bit (Masonry Bit)
Slotted-Head Drill Tips	Sandpaper (Various Grades)
Redwood Stain	Wood Putty
Gray Wash Stain	Rags

# ASSEMBLY INSTRUCTIONS

The following sections will tell you how to assembly your gazebo. If you have any questions, problems with material and/or parts, please contact your local retailer.

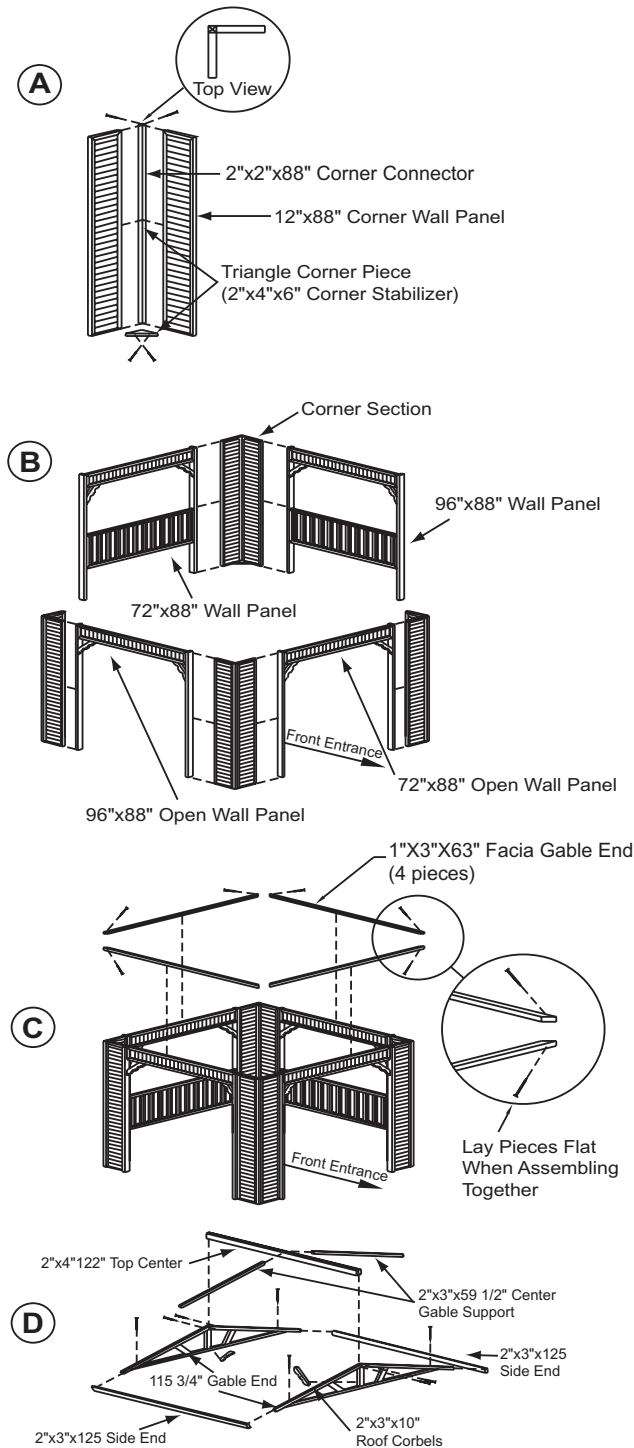

**Figure 2. Wall and Roof Frame Assembly**

## Wall Panel Assembly

**NOTE:** Please follow the written steps in conjunction with the figures that are shown.

1. Assemble all corner pieces together first (**Figure 2A**).
2. Stand the 12"x88" corner wall panels up first. Using the 2"x2"x88" corner connector, attach the wall panel and corner connector together using the provided drywall screws (**Figure 2A**).
3. Attach the 2"x4"x6" corner stabilizer (triangle-shaped wood) and attach in two locations: at the bottom of the wall and 44" from the bottom of the wall (**Figure 2A**).
4. Repeat these steps until all 4 corner pieces are assembled.
5. Following **Figure 2B**, stand the the 72"x88" front entrance open wall panel and attach it to the corner piece with the provided drywall screws.
6. Attach the 96"x88" open wall panel to the corner piece. Repeat this step until all of the walls are attached to all of the corner pieces (**Figure 2B**).

**NOTE:** Both 96"x88" panels will be directly across from each other. The 72"x88" panels will be directly across from each other as well.

7. Put all the frame parts in one place. It is advised that the frame be assembled prior to installation. Place on a flat surface and assemble (**Figure 2C**).

## Roof Frame Assembly

**NOTE:** Please follow the written steps in conjunction with the figures that are shown.

1. Layout both 115 3/4" gable end pieces. Attach the 2"x3"x125" side end pieces and the 2"x4"x122" top center board to the gable end pieces with the provided drywall screws (**Figure 2D**).
2. Find the the midway point between the top center board and the side end boards. Attach the 2"x3"x59 1/2" center gable support boards at these points with drywall screws (**Figure 2D**).
3. Attach the 2"X3"X10" gable roof corbels to the top center board and the gable ends (**Figure 2D**).

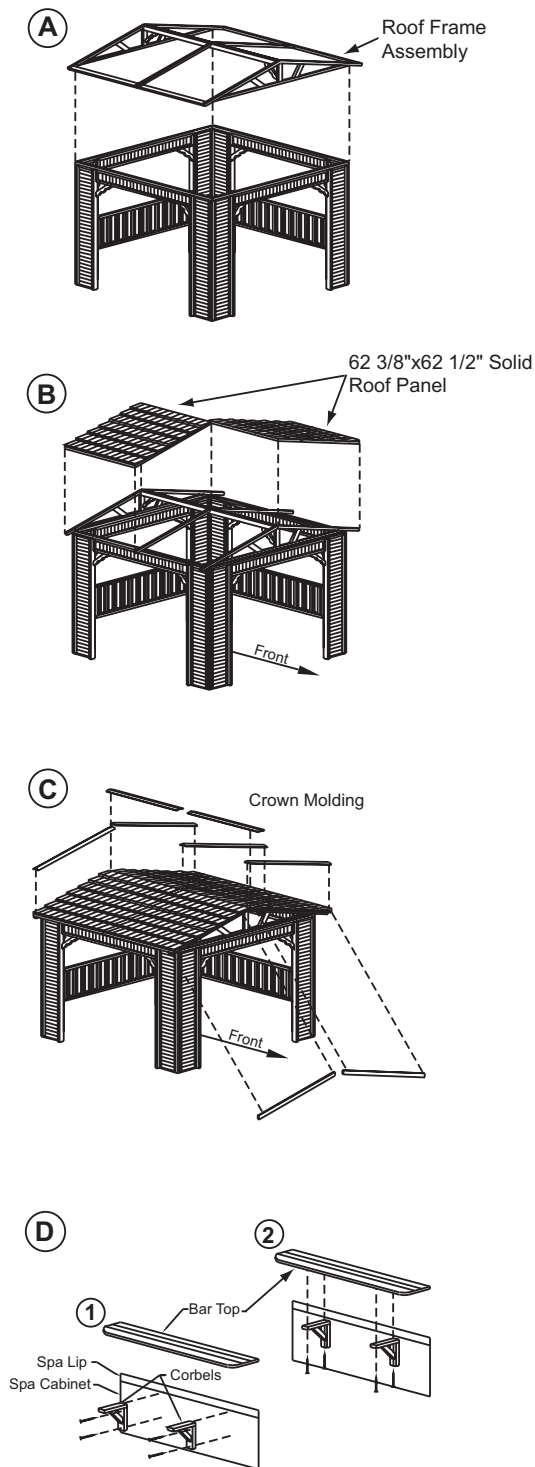

**Figure 3.** Composition Roof Assembly

## Composition Roof Assembly

**NOTE:** It is suggested that the owner have a helper for the next steps, as heavy objects must be lifted.

1. Place the assembled roof frame onto the assembled wall panels (**Figure 3A**) and attach using the provided drywall screws.
2. Attach the 62 3/8"x62 1/2" solid roof panels (4 each) to the roof frame, using the provided drywall screws (**Figure 3B**).
3. Attach the crown molding with the provided drywall screws (**Figure 3C**).

**NOTE:** The manufacturer recommends mounting corbels on the cabinet so that the bar top sits just under the spa lip.

4. Using drywall screws, mount the corbels directly to the cabinet wall (**Figure 3D-1**). Make sure that the corbels are horizontally level with each other.
5. Mount the bar top to the corbels with the drywall screws (**Figure 3D-2**). The screws must be mounted from the underside of the bar top. Make sure that the bar top rests just below the lip of the spa.

# CLEANING, MAINTENANCE AND TROUBLESHOOTING

## Cleaning

Your gazebo was designed with low cleaning and maintenance in mind. We recommend that the gazebo be cleaned at least twice a month (or more, if needed). When cleaning your gazebo, cleaning solvents are not recommended. Using a sponge and water will be fine. For ground-in dirt and grime, please refer to the following section.

## Maintenance

Maintaining your gazebo will be an easy task. We recommend that every six months you should do an inspection of the wood on your gazebo. Take note of any deformities in the wood (i.e. cracking, peeling, dirt, grime, etc.). It is recommended that you spot sand these areas with 120-grit sandpaper. When complete, wipe these areas clean with a damp rag.

When dry, you must apply a coat of stain to the sanded area. Wipe the stained area clean and reapply until the sanded area matches the rest of the gazebo.

**NOTE:** An 8oz. can of stain will be supplied with each gazebo. To replace the can of stain, please contact your local Cal Enclosures dealer.

**NOTE:** On models that have plexi-glass windows, the use of a cheese cloth and warm water should be used. These windows are made of plexi-glass and do not hold up well under the abrasive conditions that many commercial cleaners generate.

## TROUBLESHOOTING PROCEDURES

**Q: Why will the windows on the gazebo not stay open/closed?**

**A:** This is most likely due to the fact that your foundation is not level. Foundations will most likely have a 1/4" pitch for drainage reasons. To rectify this problem, the gazebo must be shimmed on the low side. Using a standard level, shim the low side so that the gazebo is level.

**Q: Why won't the roof panels not sit correctly on the roof frame?**

**A:** Check the top plate on the top center frame and make sure it is level and installed correctly.

**Q: My roof and wall panels are not lining up correctly and there are small gaps in the joint seams. Why is this?**

**A:** The main support post is not "plumb" (meaning vertically level). You must go back and make sure that the main support post is plumb. Also, you must make sure that each of your main support beams is "square" in relation to the main support post (meaning that there is a 90° angle when the main support post and the main support beam intersect).

## APPENDIX

The items that will be covered in this section will consist of the following:

Accessories

Part Numbers

Notes

In order for your retailer to expedite your order, for parts and accessories, it is recommended that you have the information that you attained in the Set-Up and Delivery section. Customer Service will want all this information for warranty purposes.

## ACCESSORIES

The following is a list of all the accessories that you can use with your Cal Spa Creative Wood Designs Gazebo. If you wish to order an accessory, feel free to contact your dealer with the desired part name and part number, or visit [www.calspas.com](http://www.calspas.com).

<b>Description</b>	<b>Size</b>	<b>Wood</b>	<b>Part Number</b>	
			<b>Cal Stone</b>	<b>Deluxe Stone</b>
Bar Top	11'	WOOD289	WOOD289CS	WOOD289DS
	80'	WOOD288	WOOD288CS	WOOD288DS
	75'	WOOD287	WOOD287CS	WOOD287DS
Round Corner		WOOD199	WOOD199CS	WOOD199DS
Storage Bench	11'	WOOD905	WOOD905CS	WOOD905DS
	80'	WOOD902	WOOD902CS	WOOD902DS
	75'	WOOD901	WOOD901CS	WOOD901DS
Crescent S/B		WOOD900	WOOD900CS	WOOD900DS
Bar Corbel		WOO270405060		
Bench Leg		WOO27405020		
Bar Stool		WOOD127	WOOD127CS	WOOD127DS
Surround Step	11'	WOOD296		
	80'	WOOD297		
	75'	WOOD298		
Crescent Step		WOOD214		
30' Step		WOOD107		
30" Storage Step w/Box		WOOD133		
5' Step		WOOD109		
5' Step Storage w/Box		WOOD134		
30" Step w/Handrail		WOOD107-2		
Round Planter		WOOD101		
Square Planter		WOOD100		
Crown Planter		WOOD189		
Octagon Planter		WOOD148		
Crescent Planter		WOOD168		
Bench	11'	WOOD923	WOOD923CS	WOOD923DS
	80'	WOOD922	WOOD922CS	WOOD922DS
	75'	WOOD921	WOOD921CS	WOOD921DS
Crescent Bench		WOOD920	WOOD920CS	WOOD920DS
Privacy Panel		WOOD183		
30" Step (3 tier)	30"	WOOD108		
30" Step (3 Tier with Handrail)	30"	WOOD108-2		
Towel/Wine Glass Rack	4'	WOOD113		
Towel/Wine Glass Rack	5'	WOOD113-5		
Wine Glass Hanger		WOOD114		
Towel Tree		WOOD169		
Kidzone Playhouse		KDZ100		
Corner Towel Bar		WOO27402175		

**8'x8' FRONTIER GAZEBO**

<b>Item Number</b>	<b>Description</b>	<b>Part Number</b>	<b>Quantity</b>
1	12'x88" Corner Wall Panel Solid	WOO27103610	8
2	2"x2"x88" Corner Connector	WOO27106920	4
3	72"x88" Open Wall Panel	WOO27103630	1
4	96"x88" Open Wall Panel	WOO27103635	1
5	72"x88" Wall Panel	WOO27103615	1
6	96"x88" Wall Panel	WOO27103625	1
7	2'x4'x6' Corner Stabilizer	WOO27200600	8
8	2'x3'x101" Header Board m2	WOO27107510	2
9	2'x3'x125" Header Board m2	WOO27107515	2
10	115 3/4" Gable End	WOO27210185	2
11	2'x4'x122" Top Center	WOO27211470	2
12	2'x3'x125" Side End	WOO27210190	2
13	2'x3'x59 1/2" Center Support Gable Roof	WOO27503780	2
14	1"x3"x63" Facia Gable End	WOO27210285	4
15	62 3/8"x62 1/2" Solid Roof Panel	WOO27201030	4
16	2"x4"x58 1/4" Crown Molding	WOO27208285	1
17	2"x4"x63 1/4" Crown Molding	WOO27208285	6
18	8"x3" Screw SQ Drive Drywall	HAR13201140	30
19	8"x2.5" Screw SQ Drive Drywall	HAR13201150	100
20	2"x3"x10' Gable Roof Corbels	WOO27211520	2
21	2"x4"x16" Roof Corbels m2	WOO27200060	4
22	11'x69" Premier Bar	WOO27301500	1
23	Bar Stools	WOO27403300	2
24	Bar Corbels	WOO27300360	2
25	8oz. Can of Touch-Up Paint/ Stain		1
26	Registration Card		1
27	Warranty		1

**8'x10' FRONTIER GAZEBO**

<u>Item Number</u>	<u>Description</u>	<u>Part Number</u>	
<u>Quantity</u>			
1	12'x88" Corner Wall Panel Solid	WOO27103610	8
2	2"x2"x88" Corner Connector	WOO27106920	4
3	72"x88" Open Wall Panel	WOO27103630	1
4	120"x88" Open Wall Panel	WOO27103635	1
5	72"x88" Wall Panel	WOO27103615	1
6	120"x88" Wall Panel	WOO27103625	1
7	2'x4'x6' Corner Stabilizer	WOO27200600	8
8	2'x3'x101" Header Board m2	WOO27107510	2
9	2'x3'x125" Header Board m2	WOO27107515	2
10	115 3/4" Gable End	WOO27210185	2
11	2'x4'x122" Top Center	WOO27211470	2
12	2'x3'x125" Side End	WOO27210190	2
13	2'x3'x59 1/2" Center Support Gable Roof	WOO27503780	2
14	1"x3"x63" Facia Gable End	WOO27210285	4
15	62 3/8"x62 1/2" Solid Roof Panel	WOO27201030	4
16	2"x4"x58 1/4" Crown Molding	WOO27208285	1
17	2"x4"x63 1/4" Crown Molding	WOO27208285	6
18	8"x3" Screw SQ Drive Drywall	HAR13201140	30
19	8"x2.5" Screw SQ Drive Drywall	HAR13201150	100
20	2"x3"x10' Gable Roof Corbels	WOO27211520	2
21	2"x4"x16" Roof Corbels m2	WOO27200060	4
22	11'x69" Premier Bar	WOO27301500	1
23	Bar Stools	WOO27403300	2
24	Bar Corbels	WOO27300360	2



**8'x12' FRONTIER GAZEBO**

<b><u>Item Number</u></b>	<b><u>Description</u></b>	<b><u>Part Number</u></b>	<b><u>Quantity</u></b>
1	12"x88" Corner Wall Panel Solid	WOO27103610	8
2	2"x2"x88" Corner Connector	WOO27106920	4
3	72"x88" Open Wall Panel	WOO27103630	1
4	144"x88" Open Wall Panel	WOO27103635	1
5	72"x88" Wall Panel	WOO27103615	1
6	144"x88" Wall Panel	WOO27103625	1
7	2'x4'x6' Corner Stabilizer	WOO27200600	8
8	2'x3'x101" Header Board m2	WOO27107510	2
9	2'x3'x125" Header Board m2	WOO27107515	2
10	115 3/4" Gable End	WOO27210185	2
11	2'x4'x122" Top Center	WOO27211470	2
12	2'x3'x125" Side End	WOO27210190	2
13	2'x3'x59 1/2" Center Support Gable Roof	WOO27503780	2
14	1"x3"x63" Facia Gable End	WOO27210285	4
15	62 3/8"x62 1/2" Solid Roof Panel	WOO27201030	4
16	2"x4"x58 1/4" Crown Molding	WOO27208285	1
17	2"x4"x63 1/4" Crown Molding	WOO27208285	6
18	8"x3" Screw SQ Drive Drywall	HAR13201140	30
19	8"x2.5" Screw SQ Drive Drywall	HAR13201150	100
20	2"x3"x10' Gable Roof Corbels	WOO27211520	2
21	2"x4"x16" Roof Corbels m2	WOO27200060	4
22	11'x69" Premier Bar	WOO27301500	1
23	Bar Stools	WOO27403300	2
24	Bar Corbels	WOO27300360	2

# NOTES

\$5.00



# 2004 Owner's Manual

## CABANA GAZEBO

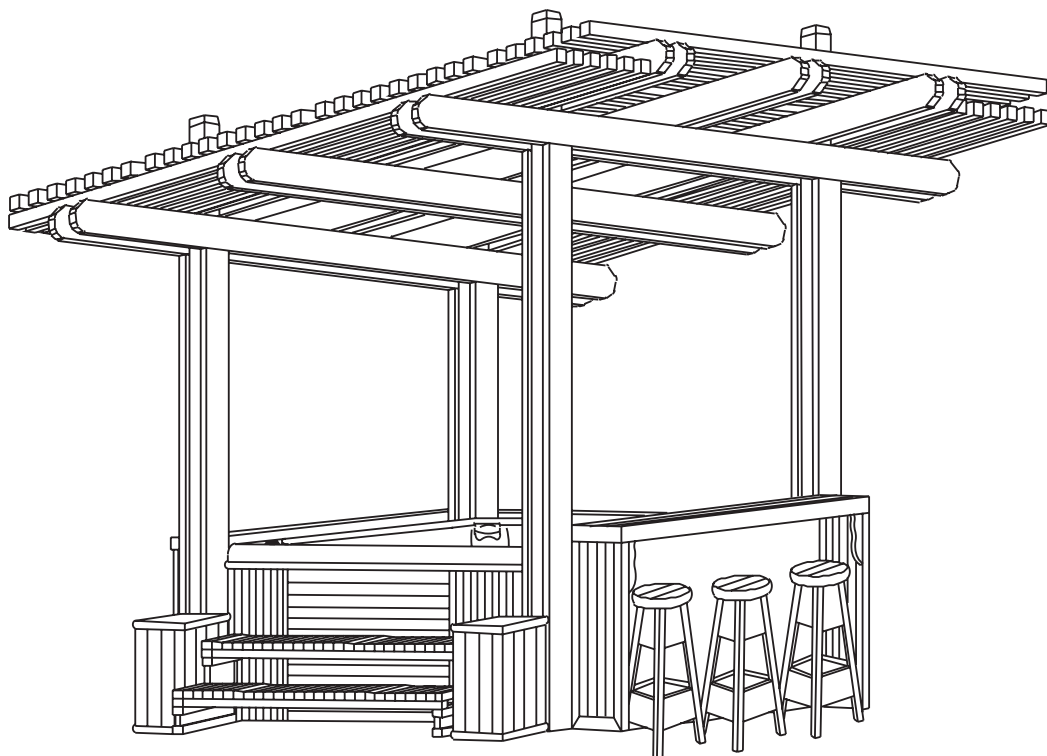

Duplication without written consent is strictly prohibited.

This Owner's Manual is for gazebos manufactured after January 1, 2004

Due to continuous improvement programs, all models, operation, and/or specifications are subject to change without prior notice.

LTR17000771

# Table of Contents

Benefits of Owning a Gazebo .....	2
Safety Instructions .....	3
Contact Information.....	4
Warranty Information .....	4
Set-up and Delivery .....	5
Assembly .....	9
Cleaning, Maintenance and Troubleshooting .....	19
Appendix .....	19
Parts List.....	20
Accessories .....	23
Notes.....	24

## BENEFITS OF OWNING A GAZEBO

Owning a gazebo allows you to have a wonderful place to unwind after a long day of work. It offers a place for you to socialize with family and friends. It offers great cover in the event that you purchase a barbeque and/or spa. Owning a gazebo can add character to your patio and your yard. You can use a gazebo for whatever best suits your needs.

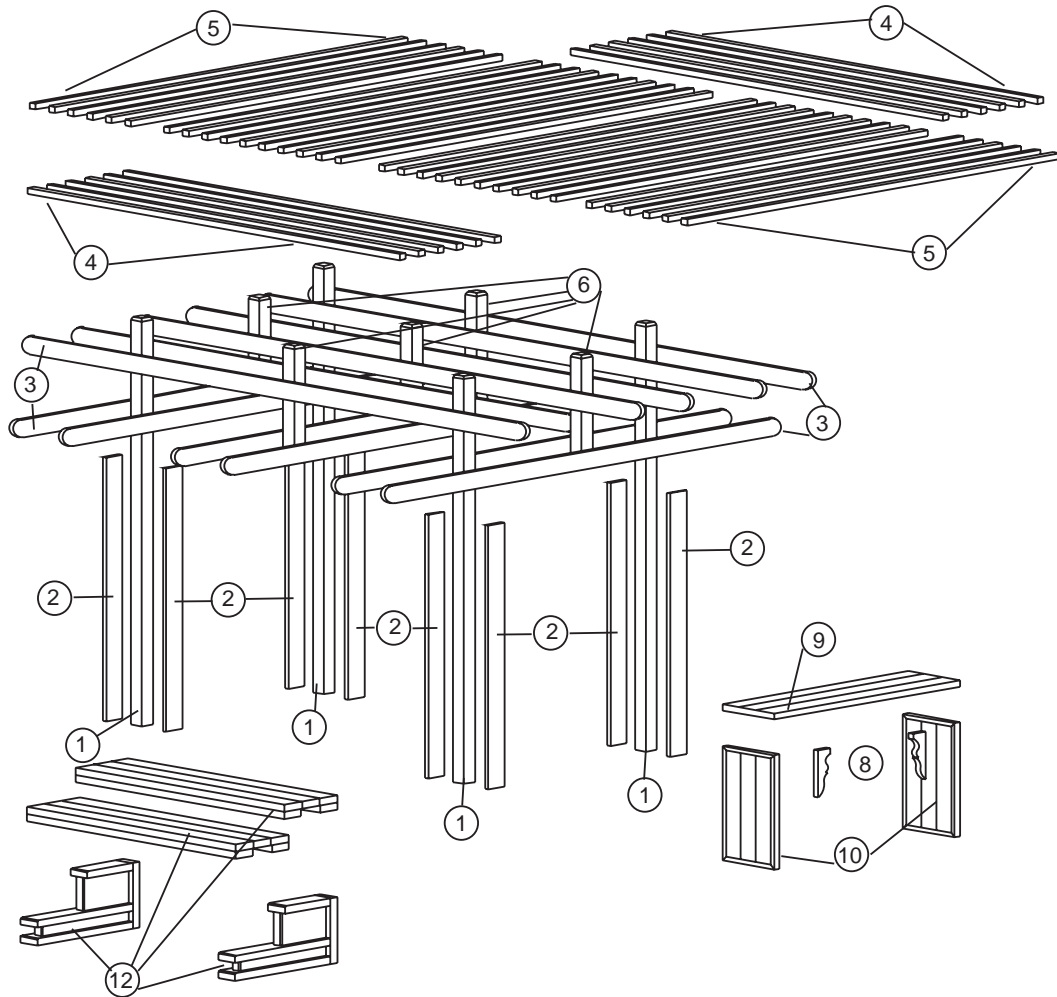

**Figure 1.** Cabana Gazebo (Exploded View)

**NOTE:** Please refer to the parts list located at the end of this manual for a full description on each item number shown above.

## **SAFETY INSTRUCTIONS**

### **Carefully read and follow all safety instructions.**

1. When installing and assembling your gazebo, it is recommended that 2 or more people be involved.
2. Do not use the unit during an electrical storm, as there is a remote chance of getting struck by lightning.
3. Do not climb on top of the gazebo. While the gazebo is made out of high-quality wood and is extremely durable, the gazebo is not meant to be used as a jungle gym. Thus, falling off of the gazebo while climbing on it can result in serious injury, possibly even death.
4. Do not attempt any repair without consulting the manufacturer first. Unauthorized repair attempts will void the manufacturer's warranty (within the first 90 days).

**Save this information.**

## CONTACT INFORMATION

For customer service, please contact your authorized dealer immediately. If you need additional information and/or assistance, please contact:

C.A.I. Customer Service Department  
1462 East Ninth Street  
Pomona, CA 91766  
Toll Free: 1-800-CAL-SPAS  
Fax: 1-909-629-3890

## WARRANTY INFORMATION

See your Cal Enclosures gazebo dealer for a copy of the applicable warranty, details and any questions you may have regarding the warranty coverage on your gazebo.

### Warranty Limitations

The Limited Warranty is void if the gazebo has been subject to negligence, alteration, misuse, abuse, repairs by non- C.A.I. authorized representatives, acts of God and any other cases beyond the control of C.A.I. Examples of common acts invalidating this warranty include but are not limited to:

Use of the gazebo in a non-residential application.

Scratches caused by normal use.

Damage caused by extreme weather conditions. (Hot, cold, etc.)

Damage caused by dirt, sand, and/or water damage.

Damage caused by direct sunlight.

Damage caused as a result of failure to follow the assembly instructions as defined in this Owner's Manual.

This Limited Warranty applies only to gazebos normally used for personal, family, or household purposes.

This Limited Warranty is obsolete 90 days after the original purchase date.

### Warranty Exclusions

C.A.I. warrants the gazebo from defects in material and workmanship for a period of 90 days from the original date of purchase.

**REMINDER: PLEASE DO NOT FORGET TO REGISTER YOUR NEW PRODUCT AT [WWW.CALSPAS.COM](http://WWW.CALSPAS.COM)**

## DELIVERY AND SET-UP

Please make a record of the following. It will be valuable if service is required.

Gazebo Model: \_\_\_\_\_

Gazebo Serial Number: \_\_\_\_\_

Date Purchased: \_\_\_\_\_

Date Installed: \_\_\_\_\_

Gazebo Dealer's Phone Number: \_\_\_\_\_

Gazebo Dealer's Address: \_\_\_\_\_

Most cities and counties require permits for exterior construction and electrical circuits. In addition, some communities have codes requiring residential barriers such as fencing and/or self-closing gates on property to prevent unsupervised access to the property by children under the age of 5. Your dealer can provide information on which permits may be required and how to obtain them prior to the delivery of your equipment.

### Planning the Best Location for Your Gazebo

Here are some of the things that you will need when considering where to locate your new gazebo.

#### How Will You Use Your Gazebo?

How you intend to use your gazebo will help you determine where you should position it. For example, will you use your gazebo for recreational purposes? If your gazebo is mainly used for family functions, be sure to leave plenty of room around it for activity. In any case dealing in how it is to be used, you'll probably want to create a specific mood around it.

#### Consider Your Privacy

In a cold weather climate, bare trees won't provide much privacy. Think of your gazebos surroundings during all seasons to determine your best privacy options. Consider the view of your neighbors as well, when you plan the location of your gazebo.

#### Provide A View With Your Gazebo

Think about the direction you will be facing when sitting in your gazebo. Do you have a special landscaped area in your yard that you find enjoyable? Perhaps there is an area that catches a soothing breeze during the day and lovely sunset in the evening. Consider these things when you plan your location.



**PREPARING A GOOD FOUNDATION**

Your gazebo needs a solid and level foundation. The area that it sits on must be able to support the weight of the gazebo and the occupants who use it. If the foundation is inadequate, it may shift or settle after the gazebo is in place, causing stress that could **DAMAGE YOUR GAZEBO**.

**NOTE:** Damage caused by inadequate or improper foundation support is not covered by the warranty. It is the responsibility of the gazebo owner to provide a proper foundation for the spa.

Place the gazebo on an elevated foundation (**preferably a 3” concrete slab**). Be sure that the concrete slab is at least 12” wider than the outside dimension on the gazebo. (See **NOTE:** on page 8.)

- \* If you are installing your spa on an elevated wood deck or other structure, it is highly recommended that you consult a structural engineer or contractor to ensure the structure will support the weight of 150 Lbs./ sq. ft.
- \* It is strongly recommended that a qualified, licensed contractor prepare the foundation for your spa.

**Your Cal Enclosures Retailer Can Help You With Foundations And More**

Your retailer has a wealth of information and experience about how to get the most out of your gazebo. Your gazebo retailer also has a full line of accessories that are engineered to compliment your gazebo.

**NOTE:** It is strongly advised that you have a licensed professional install the foundation for your new gazebo. It is imperative that the foundation is level, as any damage that occurs due to an uneven foundation is not covered by the warranty.

**Size Specifications**

<u>Model</u>	<u>Length</u>	<u>Width</u>
Frontier Gazebo	8'	8'
	10'	8'
	12'	8'
Cottage Gazebo	8'	8'
<b>Cabana Gazebo</b>	<b>7'</b>	<b>7'</b>
	<b>7.5'</b>	<b>7.5'</b>
	<b>8'</b>	<b>8'</b>
Northeast Gazebo	7.5'	7.5'
	8'	8'
Lattice Wall Gazebo	7'	7'
	7.5'	7.5'
	8'	8'
	12'	8'
	16'	8'
	10'	10'
	12'	10'
	16'	10'
12'	12'	

<b><u>Model</u></b>	<b><u>Length</u></b>	<b><u>Width</u></b>
Lattice Wall Gazebo (cont.)	12'	12'
	16'	12'
	10' (Octagon)	10'
	12' (Octagon)	12'
Plexi Wall Gazebo	7'	7'
	7.5'	7.5'
	8'	8'
	12'	8'
	16'	8'
	10'	10'
	12'	10'
	12'	12'
	16'	12'
	10' (Octagon)	10'
	12' (Octagon)	12'
	15' (Octagon)	15'
18' (Octagon)	18'	
Luxury Wall Gazebo	7'	7'
	7.5'	7.5'
	8'	8'
	12'	8'
	16'	8'
	10'	10'
	12'	10'
	16'	10'
	12'	12'
	16'	12'
Savannah Wall Gazebo	12'	8'
	10'	10'
	12'	10'
	16'	10'
	12'	12'
	16'	12'
	10' (Octagon)	10'
	12' (Octagon)	12'
15' (Octagon)	15'	
18' (Octagon)	18'	
Timberline Gazebo	12'	8'
	10'	10'
	12'	10'
	12'	12'
	16'	12'

<b><u>Model</u></b>	<b><u>Length</u></b>	<b><u>Width</u></b>
Lighthouse Gazebo	10'	10'
	12'	10'
	12'	12'
	16'	12'
Plantation Gazebo	10'	10'
	12'	10'
	12'	12'
	16'	12'
Chalet Gazebo	12'(Octagon)	12'
	14'(Octagon)	14'
	16'(Octagon)	16'
Victorian Gazebo	12'(Octagon)	12'
	14' (Octagon)	14'
	16' (Octagon)	16'

**NOTE:** The gazebo above that is listed in bold lettering is the gazebo that you purchased.

**NOTE:** For all gazebos, regardless of model, it is recommended that the foundation extend beyond the dimension of the gazebo. For example, if the gazebo you purchased is 12'x12', you will want your foundation to be 14'x14'. The reason for this is because it will be easier to maintain the area around the gazebo (mowing the lawn, edging, etc.) without damaging or scarring the gazebo. Also, in doing this, you will eliminate any potential problems, foundation-wise, in the future.

**NOTE:** This Owner's Manual applies to the various sizes that are included in the Cabana Gazebo line (7'x7', 7.5"x7.5", and 8"x8"). While the sizes will vary from gazebo to gazebo, the assembly instructions will be the same, unless otherwise noted.

## **Tools and Materials**

Utility Knife	25' Tape Measure
Cordless Drill	100' Extension Cord
1/8" Pilot Hole Drill Bit	1/2" Ratchet and Impact Drill
Electric Drill	9/16" Socket
Phillips-Head Drill Tips	1/2" Carbide Drill Bit (Masonry Bit)
Slotted-Head Drill Tips	Sandpaper (Various Grades)
Redwood Stain	Wood Putty
Gray Wash Stain	Rags

## ASSEMBLY INSTRUCTIONS

The following will tell you how to assembly your gazebo. If you have any questions, problems with material and/or parts, please contact your local retailer.

**NOTE:** It is strongly advised that you have a licensed professional install the foundation for your new gazebo. It is imperative that the foundation is level, as any damage that occurs due to an uneven foundation is not covered by the warranty.

**NOTE:** When assembling the gazebo, the owner must determine one thing: What is the gazebo going to cover? If the answer is patio furniture, then the owner can place the gazebo where ever they want it. If the answer is a spa, then it is recommended that the spa be located in the center of the slab (for weight distribution) with the gazebo main supports mounted to the concrete at each of the four corners.

1. Prior to the delivery of your new Cal Spa, it is recommended that you determine where your spa will be placed. (For example: if you are going to center your spa on the concrete slab, take measurements that will enable you to determine where the edges of the spa will be located. When done, mark the corner locations.)
2. Upon delivery of your new Cal Spa, notify the installation crew that you have determined where you want the spa located.
3. After the spa has been installed and is operating, the assembly of the your new gazebo may begin.

**IMPORTANT NOTE:** THIS GAZEBO IS A FREE-STANDING UNIT. AS WITH ANY STRUCTURE, IT IS CRITICAL THAT ALL THE MAIN SUPPORT POSTS BE VERTICALLY LEVEL, OR PLUMB. IF THE FIRST MAIN SUPPORT POST IS NOT VERTICALLY LEVEL, OR PLUMB, THEN THE ENTIRE GAZEBO WILL NOT BE VERTICALLY LEVEL. THE BEST WAY TO KEEP THE STRUCTURE LEVEL IS TO USE A LEVEL AFTER EACH TIME AN ITEM IS ATTACHED OR TIGHTENED. THIS WILL ENSURE THAT AFTER EACH MAJOR STEP IS TAKEN, THE GAZEBO IS STILL LEVEL.

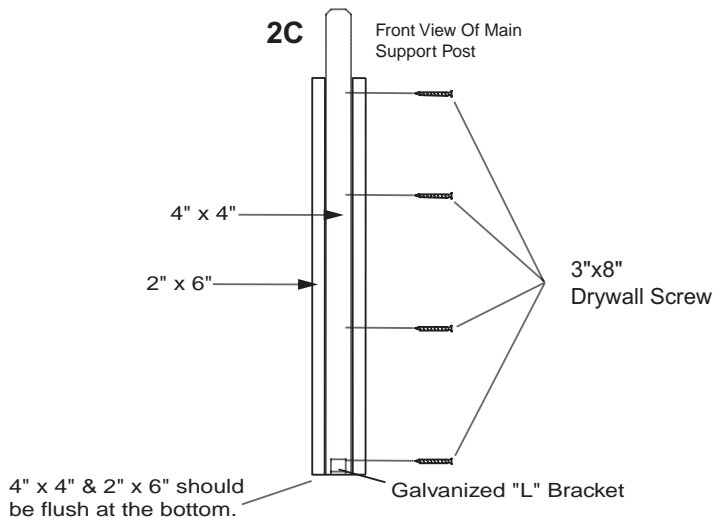
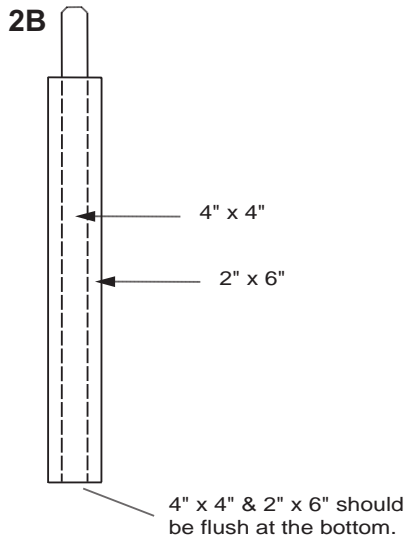
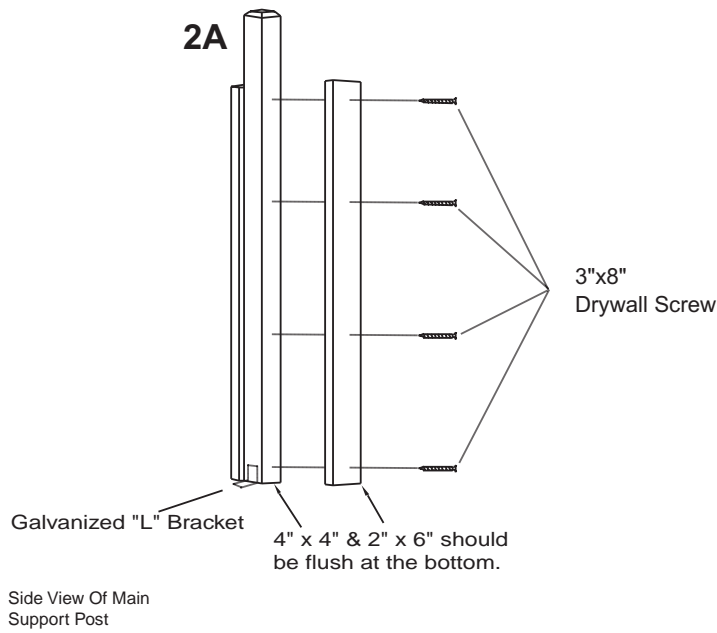

1. Using the materials that are provided in your gazebo kit, take one 4"x4"x108' (9') piece of lumber and 2 2"x6"x90" (7 1/2') pieces of lumber (**Figure 2A**).
2. Take the 2"x6" and center the lumber on the 4"x4" piece of lumber. Once this is done, take four drywall screws (3"x8") and attach the 2"x6" to the 4"x4" (**Figure 2B and 2C**). Repeat this sequence for the other 2"x6".

**NOTE:** The 4"x4" and the 2"x6" (both pieces) should be flush at the bottom.

3. Once this is complete, repeat these steps for all four sides of the gazebo.
4. Using the provided hardware, attach the galvanized "L" bracket to the 4"x4" (either side) as shown in **Figure 2C**.
5. With the use of a level, and after ensuring that the 2"x6" is between the spa and the 4"x4", check that the support is level (top to bottom), and mark the location of the anchoring hole by scoring the concrete.

**Figure 2. Cabana Support Assembly**

Determine spacing of post with spa size before anchoring into concrete.

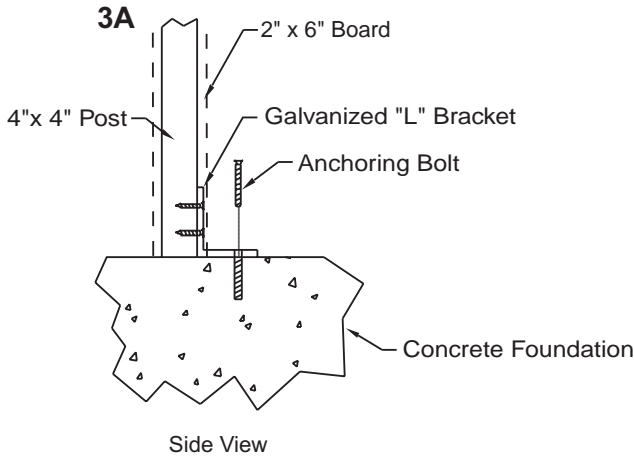

Anchor post into concrete as shown.

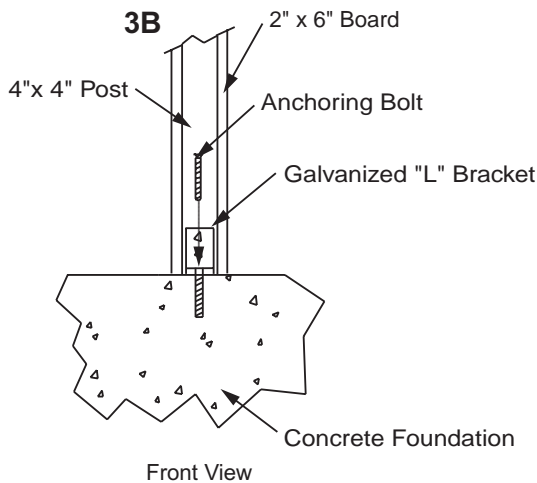
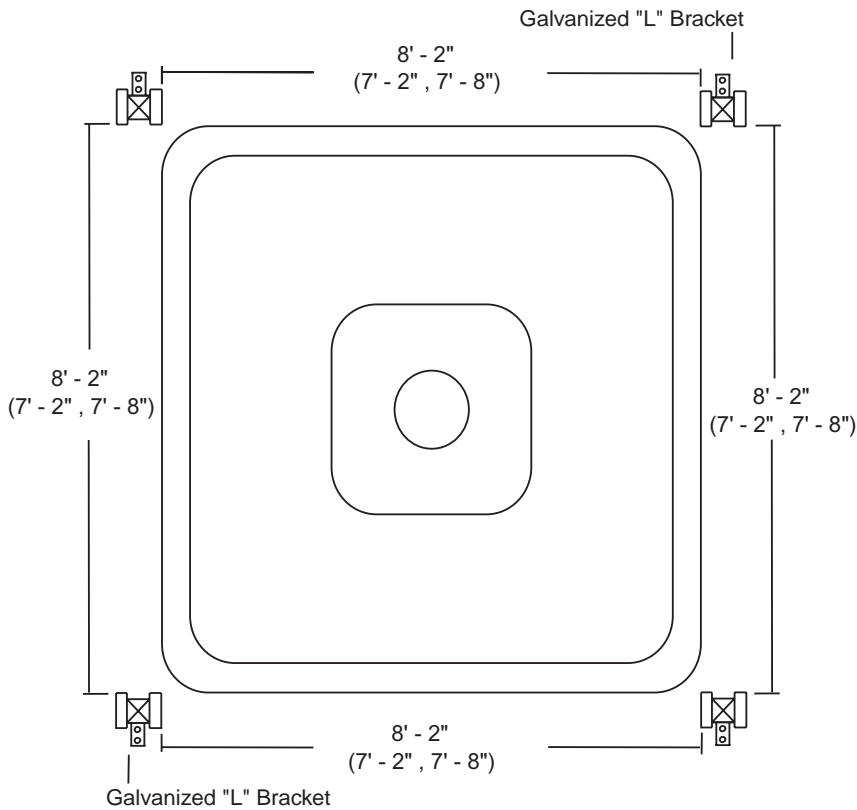

**Figure 3.** Anchoring Main Support Post

### Anchoring the Main Support Post

**NOTE:** When scoring the concrete, make sure that the mark is dark enough to see, as you will be drilling a hole in the concrete. This hole will be where the anchoring bolt is located. Also, it is the owner's responsibility to obtain a 1/2" masonry bit. This bit will be used to drill the anchoring holes in the foundation. A masonry bit may be bought at any local hardware store.

1. Pre-drill the anchoring hole using a 1/2" masonry drill bit (see **NOTE** above). Drill the hole to a depth of no less than 3". Using a hammer, insert the anchoring bolt by gently tapping the bolt into place. Continue to tap into place until the anchoring bolt is seated securely in the hole.
2. After drilling the hole and inserting the anchoring bolt, slide the main support post assembly on to the anchoring bolt and tighten down using the provided hardware.
3. Repeat these steps for all four corners of the gazebo.



The final placement of the main support posts is noted to the left (**Figure 4**). The main support posts should be mounted no less than 1" from the side of the spa. If the gazebo is touching the spa, and any damage is incurred due to contact, the warranty on the spa siding is void.

The total distance between each main support post will be determined by the size of the spa and gazebo that was purchased. The Cabana Gazebo has 3 sizes: 7'x7', 7.5'x7.5', and 8'x8'. The desired distance between each main support post will be determined by the aforementioned sizes.

**Figure 4. Main Support Post Location**

The list below will tell you what each distance should be for each gazebo model :

**If the spa is.....**

7' x 7'

7.5' x 7.5'

8' x 8'

**Then the distance between each gazebo main support post is....**

+/- 7' - 2" x 7' - 2"

+/- 7' - 8" x 7' - 8"

+/- 8' - 2" x 8' - 2"

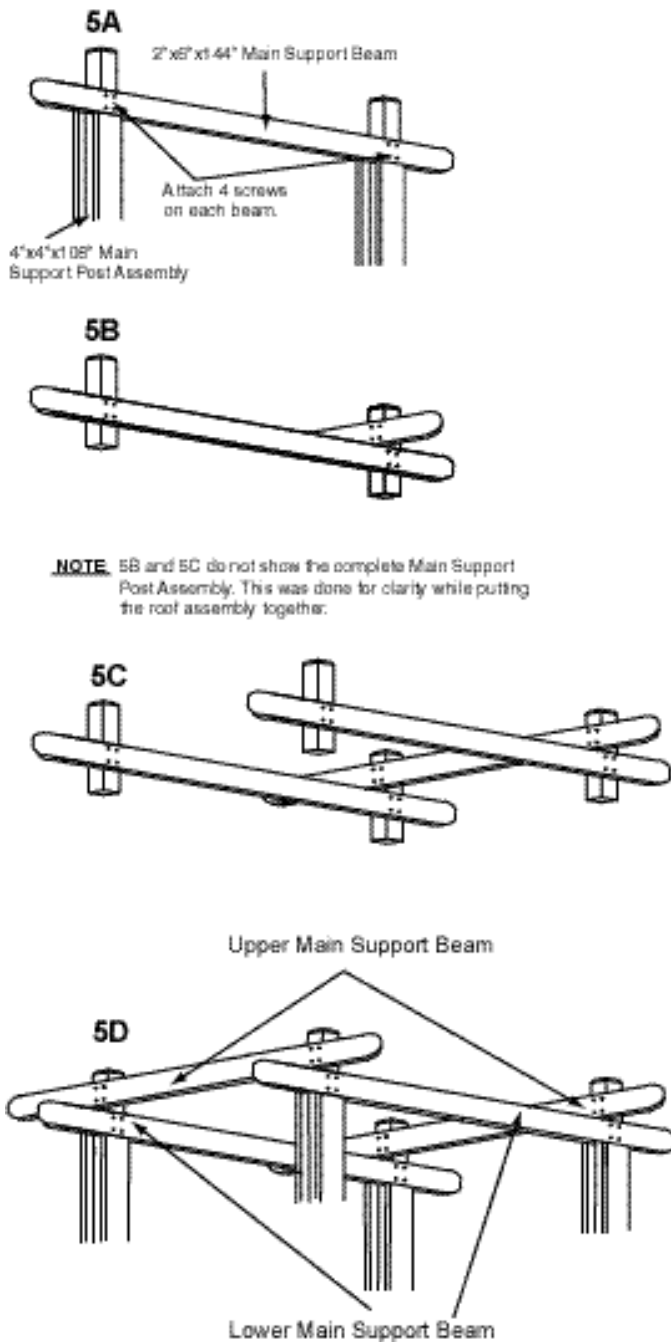

Figure 5. Roof Support Assembly

## Roof Assembly

The roof assembly is a relatively easy process. The majority of the tasks are repetitive. The first part of the roof that needs to be assembled are the support members. It is recommended that the lower support members be installed first and the upper support members second. The support members are the 2"x6"x144" (12').

### Support Member Assembly

**NOTE:** REQUIRE THE HELP OF ANOTHER PERSON. IT IS ADVISED THAT THERE BE TWO LADDERS AVAILABLE WHEN HANGING THE MAIN SUPPORT BEAMS.

**TIP:** TRY ANCHORING THE LADDERS SO THEY DO NOT MOVE WHILE YOU ARE ON TOP OF THEM.

1. With the aid of a ladder, place one 2"x6"x144" roof support on top of the 2"x6"x90" piece (see **Figure 2**) and anchor it to the 4"x4", using the provided drywall screws. Make sure that the 2"x6"x144" is centered between the two 4"x4" main support posts.
2. Place another 2"x6"x144" roof support on the opposite side of the 4"x4" main support post. Screw this piece to the 4"x4" as well.
3. Repeat this process on the other main support posts that are directly across from the main support posts that were just completed.
4. Referring to **Figure 5A**, place another 2"x6"x144" roof support on top of the roof support that was just installed. This next roof support will in effect create a 90° angle with the other 2"x6"x144" roof support. Secure the roof support with the provided drywall screws.
5. Repeat these steps for the remaining roof support beams.



A. Sectional view of 16" x 4" x 4" post. Post can be flush with bottom or be the same height as the four outer posts, as shown.

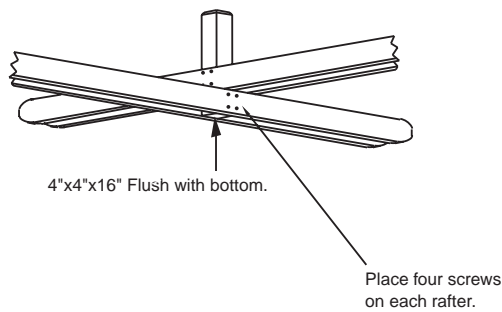

The 4"x4"x16" post is used to tie the roof grid together and re-enforce it (**Figure 6**). These posts should be mounted flush with the bottom of the roof support beams (**Figure 6**) so they are at the same height as the main support posts.

**Figure 6. Roof Re-Enforcement**

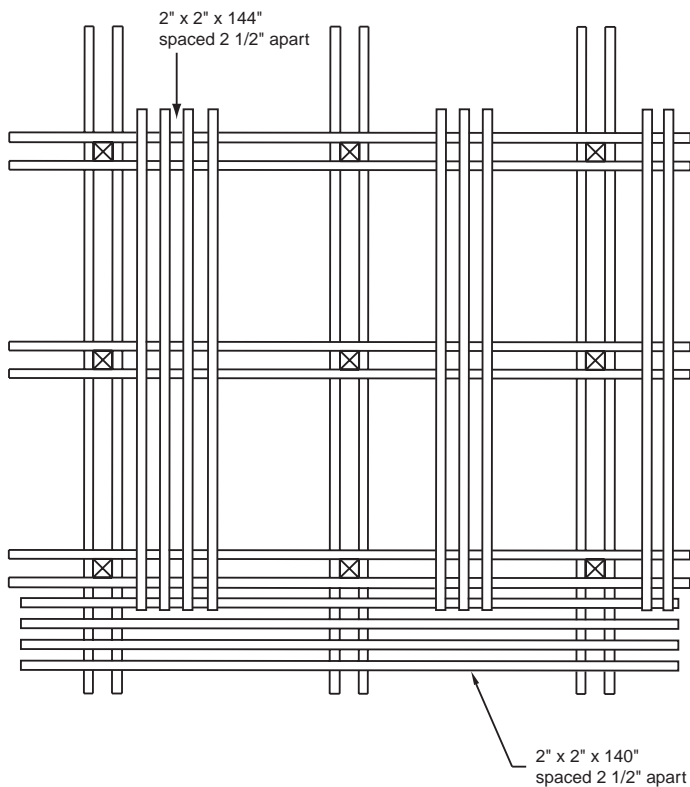

**Final Roof Assembly**

1. Lay out the 2"x2"x140" roof slats on the two lower levels of the gazebo. Make sure that each roof slat is spaced exactly 2 1/2" apart. Twelve roof slats total will be used on the lower level (**Figures 7 and 8**).
2. Secure each roof slat securely in place with 2 1/2" drywall screws.
3. Lay out the 2"x2"x144" roof slats on the one upper level of the gazebo. Make sure that each roof slat is spaced exactly 2 1/2" apart. Twelve roof slats total will be used on the lower level (**Figures 7 and 8**). These roof slats need to be running the opposite direction as the lower level roof slats.

**Figure 7. Roof Configuration**

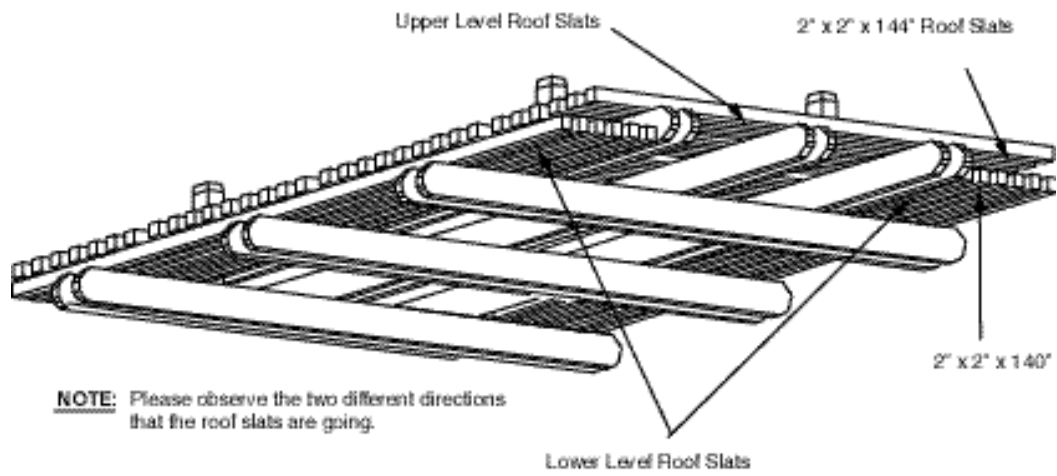

**Figure 8. Roof Configuration**

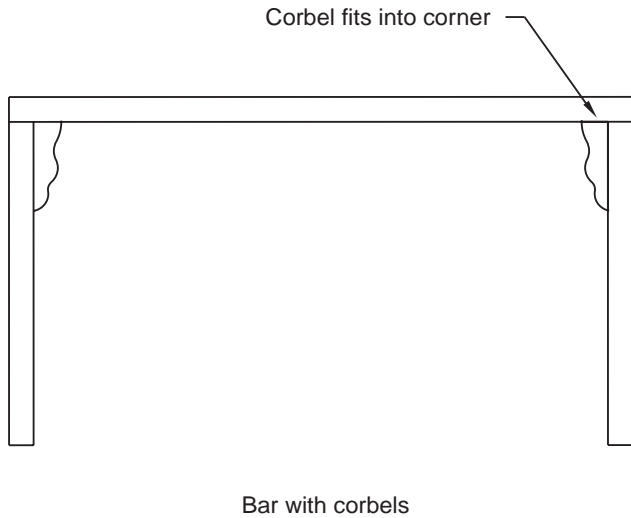

**Bar and Corbel Installation**

1. Place the bar top face down on the ground (**Figure 9**).

**NOTE:** Use care when placing the bar top on the ground. It is recommended that a sheet, or a blanket, be placed on the ground with the bar top being placed on top of the material.

2. Place the bar legs with the decorative finish facing outward. Fasten to the bar top with 2 1/2" screws.
3. Fasten bar corbel to bar top and bar legs with 2 1/2" screws.

**NOTE:** Once the bar assembly is complete, place the bar between the main support posts. Push the bar assembly all the way against the spa. Attach the bar to the main support posts by using drywall screws.

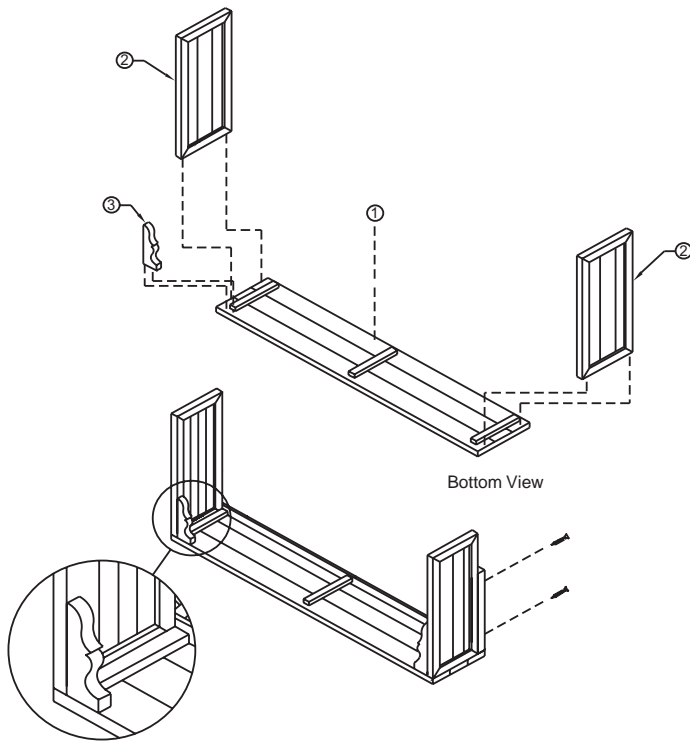

**INSTRUCTIONS**

1. Place bar top face down.
2. Place bar legs w/detail facing outwards and fasten to bar top with 2 1/2" screws.
3. Fasten bar corbel to bar top and bar legs with 2 1/2" screws.

**Figure 9.** Corbel and Bar Installation

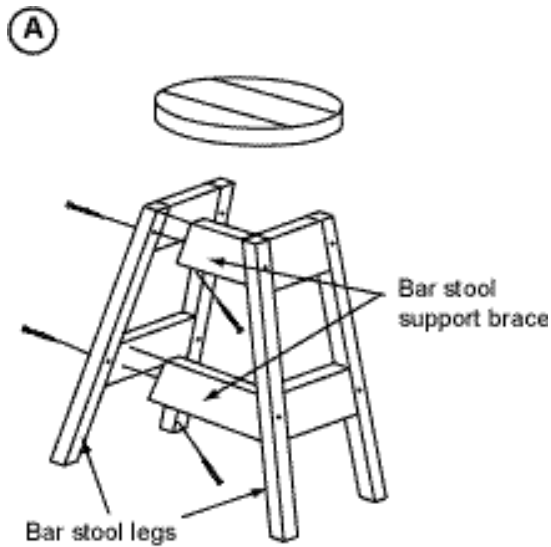

1. Attach sides to legs.

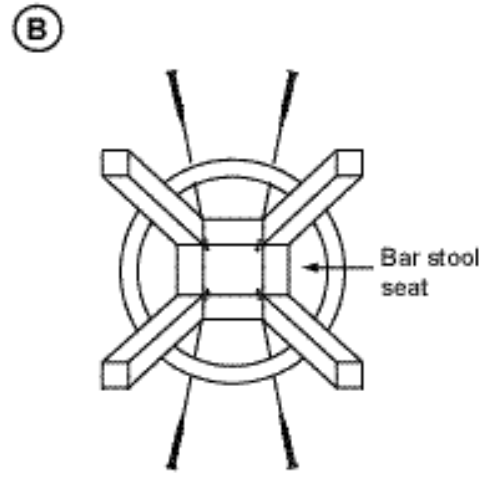

***BOTTOM VIEW***

2. Attach seat to leg assembly.



### Bar Stool Assembly

The final step in the assembly of your Cabana Gazebo is the assembly of your bar stool(s).

1. Attach the bar stool legs to the support brace using the provided drywall screws. There will be a total of 12 screws (**Figure 10A**).
2. Place the bar stool seat on a flat surface (make sure that the finish side is on the ground). Attach the leg assembly using 4 drywall screws (**Figure 10B**).

**Figure 10.** Bar Stool Assembly

## Step Assembly

The Cabana Gazebo comes with a 2-level 5' step assembly. These steps will not need to be mounted to the spa or the gazebo.

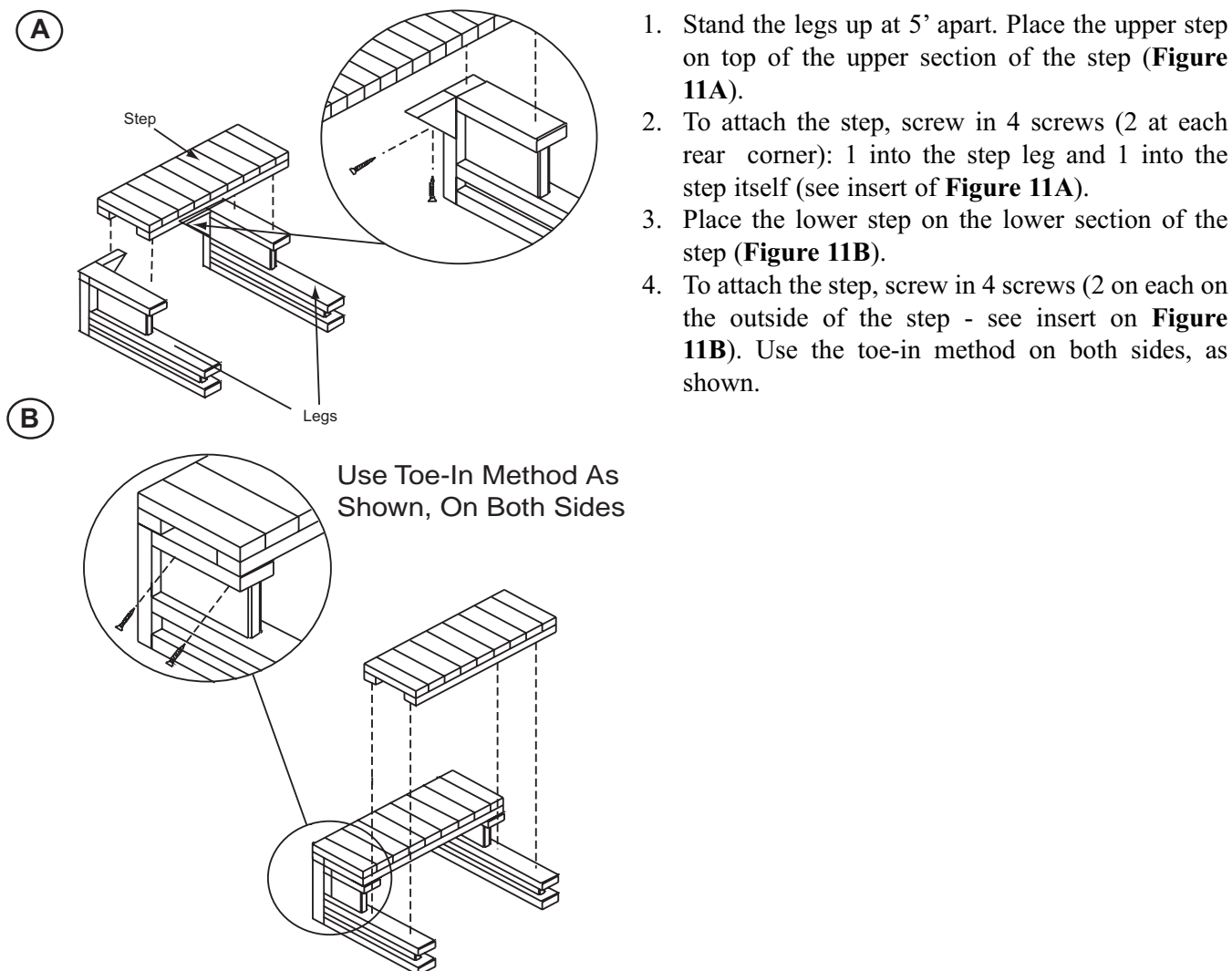

**Figure 11.** Gazebo Step Assembly

# CLEANING, MAINTENANCE and TROUBLESHOOTING

## Cleaning

Your gazebo was designed with low cleaning and maintenance in mind. We recommend that the gazebo be cleaned at least twice a month (or more, if needed). When cleaning your gazebo, cleaning solvents are not recommended. Using a sponge and water will be fine. For ground-in dirt and grime, please refer to the following section.

## Maintenance

Maintaining your gazebo will be an easy task. We recommend that every six months you should do an inspection of the wood on your gazebo. Take note of any deformities in the wood (i.e. cracking, peeling, dirt, grime, etc.). It is recommended that you spot sand these areas with 120-grit sandpaper. When complete, wipe these areas clean with a damp rag.

When dry, you must apply a coat of stain to the sanded area. Wipe the stained area clean and reapply until the sanded area matches the rest of the gazebo.

**NOTE:** An 8oz. can of stain will be supplied with each gazebo. To replace the can of stain, please contact your local Cal Enclosures dealer.

**NOTE:** On models that have plexi-glass windows, the use of a cheese cloth and warm water should be used. These windows are made of plexi-glass and do not hold up well under the abrasive conditions that many commercial cleaners generate.

## TROUBLESHOOTING PROCEDURES

**Q: Why won't the roof panels not sit correctly on the roof frame?**

**A:** Check the top plate on the top center frame and make sure it is level and installed correctly.

**Q: My roof and wall panels are not lining up correctly and there are small gaps in the joint seams. Why is this?**

**A:** The main support post is not "plumb" (meaning vertically level). You must go back and make sure that the main support post is plumb. Also, you must make sure that each of your main support beams is "square" in relation to the main support post (meaning that there is a 90° angle when the main support post and the main support beam intersect).

# PARTS LIST

## 7'x7' CABANA GAZEBO

<u>Item Number</u>	<u>Description</u>	<u>New Part Number</u>	<u>Quantity</u>
1	4'x4'x108" CLR & BTR	WOO27106760	4
2	2'x6'x90" B & BTR	WOO27402960	8
3	2'x6'x144" B & BTR	WOO27106720	12
4	2'x2'x140" B & BTR	WOO27106780	14
5	2'x2'x108" B & BTR	WOO27106800	35
6	4'x4'x16.5" CLR & BTR	WOO27106820	5
7	71" Chaise Lounge Base 12-700	WOO27402720	2
8	2'x3'x10.5" Bar Corbels (w/notch)	WOO27403060	6
9	79" Bar Top (12-700)	WOO27402420	1
10	16"x33" Bar Legs	WOO27402900	8
11	Bar Stools N/S	WOO27403300	4
12	19.5"x22" Steps, Cabana	WOO27401980	2
13	Chaise Lounge Back Rest	WOO27402480	2
14	5' Steps	WOO27401680	1
15	Square Planters	WOO27400560	2
16	8"x3" Screw SQ Drive Drywall	HAR13201140	20
17	8"x2.5" Screw SQ Drive Drywall	HAR13201150	100
18	4'x4'x12" Step, Cabana 19.5"x88" Legs	WOO27402100	8
19	10.5" Corbels (w/out notch)	WOO27210940	4
20	1/2"x2 3/4" Anchoring Bolt	HAR13900050	4
21	Gazebo Galvanized "L" Bracket	WOO27903780	4

**7.5'x7.5' CABANA GAZEBO**

<u>Item Number</u>	<u>Description</u>	<u>New Part Number</u>	<u>Quantity</u>
1	4'x4'x108" CLR & BTR	WOO27106760	4
2	2'x6'x90" B & BTR	WOO27402960	8
3	2'x6'x144" B & BTR	WOO27106720	12
4	2'x2'x140" B & BTR	WOO27106780	12
5	2'x2'x108" B & BTR	WOO27106800	35
6	4'x4'x16.5" CLR &BTR	WOO27106820	5
7	85" Chaise Lounge Base12-750	WOO27402780	1
8	2'x3'x10.5" Bar Corbel (w/notch)	WOO27403060	6
9	77" Bar Top (12-750)	WOO27402820	2
10	16"x33" Bar Legs	WOO27402900	8
11	Bar Stools N/S	WOO27403300	4
12	19.5"x22" Steps Cabana	WOO27401980	2
13	Chaise Lounge Back Rest	WOO27402480	2
14	5' Steps	WOO27401680	1
15	Square Planters	WOO27400560	2
16	8"x3" Screw SQ Drive Drywall	HAR13201140	20
17	8"x2.5" Screw SQ Drive Drywall	HAR13201150	100
18	4'x4'x12' Step Cabana 19.5"x88" Legs	WOO27402100	8
19	10.5" Corbels (w/out notch)	WOO27210940	4
20	1/2"x2 3/4" Anchoring Bolt	HAR13900050	4
21	Gazebo Galvanized "L" Bracket	WOO27903780	4



**8'x8' CABANA GAZEBO**

<b><u>Item Number</u></b>	<b><u>Description</u></b>	<b><u>New Part Number</u></b>	<b><u>Quantity</u></b>
1	4'x4'x108" CLR & BTR	WOO27106760	4
2	2'x6'x90" B & BTR	WOO27402960	8
3	2'x6'x144" B & BTR	WOO27106720	12
4	2'x2'x140" B & BTR	WOO27106780	10
5	2'x2'x108" B & BTR	WOO27106800	35
6	4'x4'x16.5" CLR &BTR	WOO27106820	5
7	85" Chaise Lounge Base12-750	WOO27402780	1
8	2'x3'x10.5" Bar Corbels (w/notch)	WOO27403060	6
9	8' Bar Top Assembly	WOO27402820	1
10	16"x33" Bar Legs	WOO27402900	8
11	Bar Stools N/S	WOO27403300	4
12	19.5"x22" Steps Cabana	WOO27401980	2
13	Chaise Lounge Back Rest	WOO27402480	2
14	5' Steps	WOO27401680	1
15	Square Planters	WOO27400560	2
16	8"x3" Screw SQ Drive Drywall	HAR13201140	20
17	8"x2.5" Screw SQ Drive Drywall	HAR13201150	100
18	1/2"x2 3/4" Anchoring Bolt	HAR13900050	4
19	Gazebo Galvanized "L" Bracket	WOO27903780	4
20	4'x4'x12' Step Cabana 19.5"x88" Legs	WOO27402100	8
21	10.5" Corbels (w/out notch)	WOO27210940	4

## ACCESSORIES

The following is a list of all the accessories that you can use with your Cal Spa Creative Wood Designs Gazebo. If you wish to order an accessory, feel free to contact your dealer with the desired part name and part number, or visit [www.calspas.com](http://www.calspas.com).

<b>Description</b>	<b>Size</b>	<b>Wood</b>	<b>Part Number</b>	
			<b>Cal Stone</b>	<b>Deluxe Stone</b>
Bar Top	11'	WOOD289	WOOD289CS	WOOD289DS
	80'	WOOD288	WOOD288CS	WOOD288DS
	75'	WOOD287	WOOD287CS	WOOD287DS
Round Corner		WOOD199	WOOD199CS	WOOD199DS
Storage Bench	11'	WOOD905	WOOD905CS	WOOD905DS
	80'	WOOD902	WOOD902CS	WOOD902DS
	75'	WOOD901	WOOD901CS	WOOD901DS
Crescent S/B		WOOD900	WOOD900CS	WOOD900DS
Bar Corbel		WOO270405060		
Bench Leg		WOO27405020		
Bar Stool		WOOD127	WOOD127CS	WOOD127DS
Surround Step	11'	WOOD296		
	80'	WOOD297		
	75'	WOOD298		
Crescent Step		WOOD214		
30' Step		WOOD107		
30" Storage Step w/Box		WOOD133		
5' Step		WOOD109		
5' Step Storage w/Box		WOOD134		
30" Step w/Handrail		WOOD107-2		
Round Planter		WOOD101		
Square Planter		WOOD100		
Crown Planter		WOOD189		
Octagon Planter		WOOD148		
Crescent Planter		WOOD168		
Bench	11'	WOOD923	WOOD923CS	WOOD923DS
	80'	WOOD922	WOOD922CS	WOOD922DS
	75'	WOOD921	WOOD921CS	WOOD921DS
Crescent Bench		WOOD920	WOOD920CS	WOOD920DS
Privacy Panel		WOOD183		
30" Step (3 tier)	30"	WOOD108		
30" Step (3 Tier with Handrail)	30"	WOOD108-2		
Towel/Wine Glass Rack	4'	WOOD113		
Towel/Wine Glass Rack	5'	WOOD113-5		
Wine Glass Hanger		WOOD114		
Towel Tree		WOOD169		
Kidzone Playhouse		KDZ100		

# NOTES

\$5.00



# 2004 Owner's Manual

## SAVANNAH GAZEBO

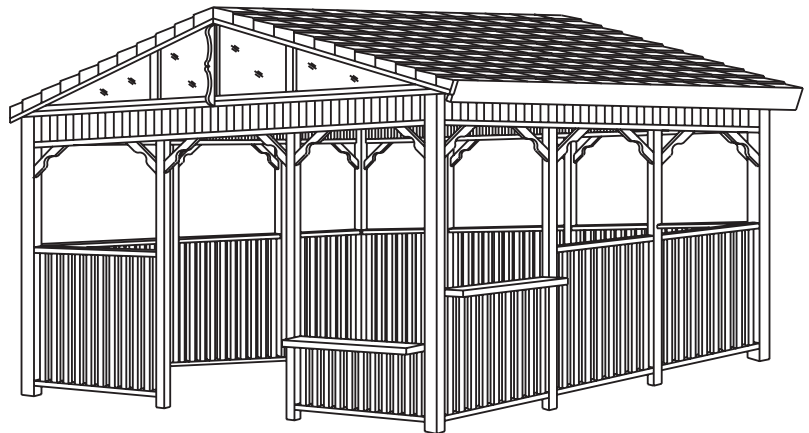
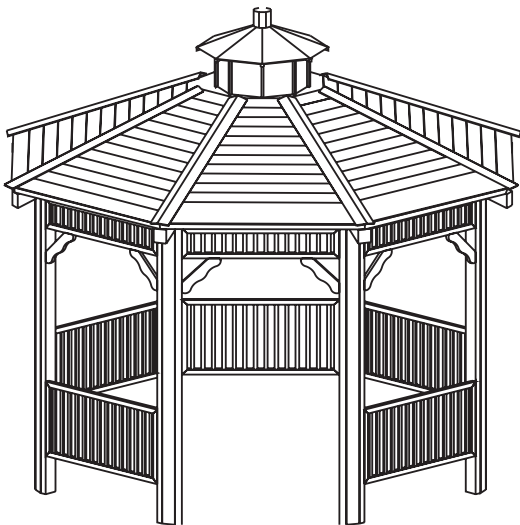

Duplication without written consent is strictly prohibited.

This Owner's Manual is for gazebos manufactured after January 1, 2004

Due to continuous improvement programs, all models, operation, and/or specifications are subject to change without prior notice.

LTR17000782

# Table of Contents

Benefits of Owning a Gazebo .....	2
Safety Instructions .....	3
Contact Information.....	4
Warranty Information .....	4
Set-up and Delivery .....	5
Assembly .....	9
Cleaning, Maintenance and Troubleshooting .....	15
Appendix .....	16
Accessories .....	17
Parts List.....	18
Notes.....	20

### BENEFITS OF OWNING A GAZEBO

Owning a gazebo allows you to have a wonderful place to unwind after a long day of work. It offers a place for you to socialize with family and friends. It offers great cover in the event that you purchase a bar-b-que and/or spa. Owning a gazebo can add character to your patio and/or yard. You can use a gazebo for whatever best suits your needs.

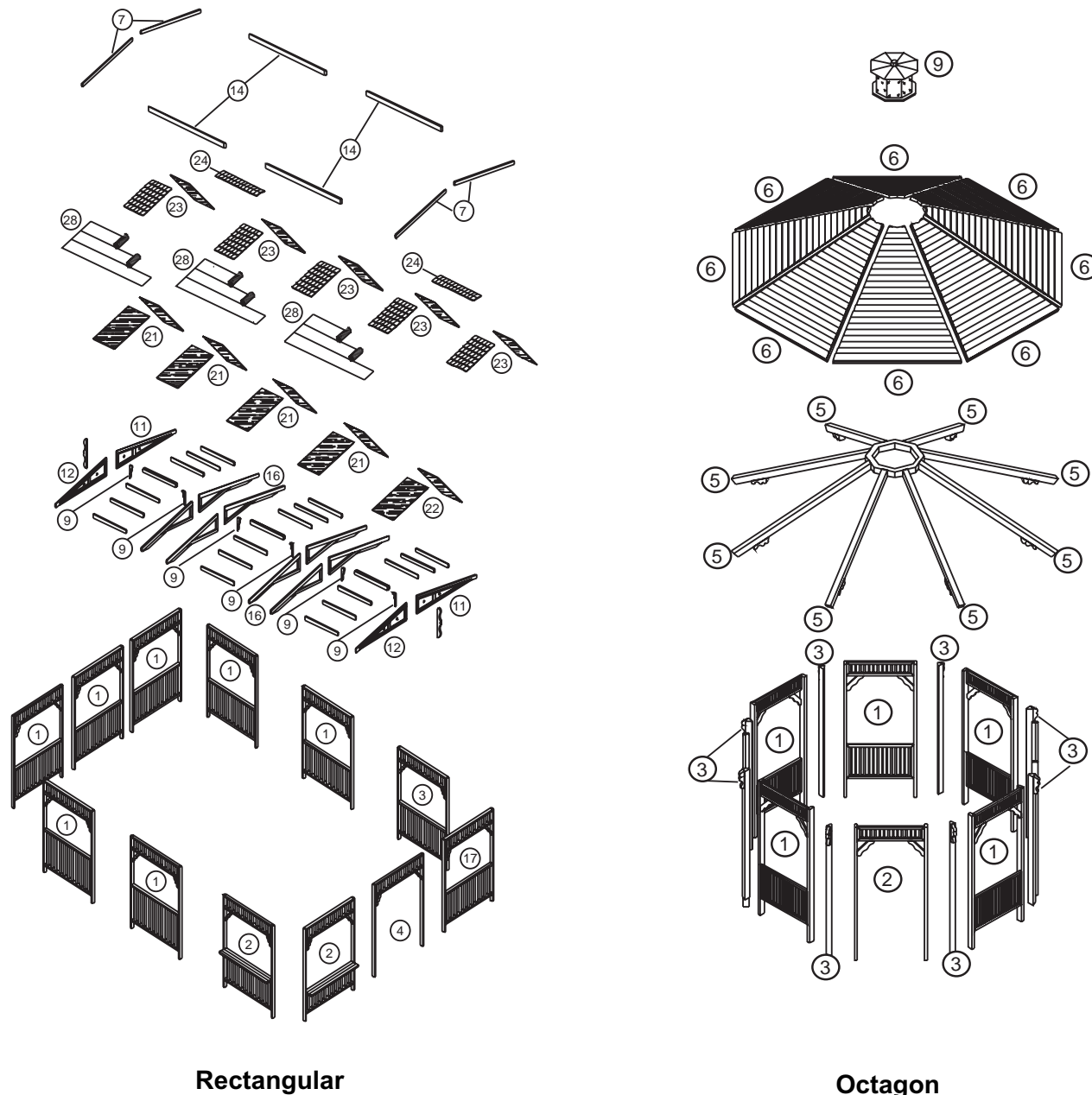

Figure 1. Savannah Gazebo

**NOTE:** Each item number listed above can be found in the “Parts List” section of this manual.

## **SAFETY INSTRUCTIONS**

### **Carefully read and follow all safety instructions.**

1. When installing and assembling your gazebo, it is recommended that 2 or more people be involved.
2. Do not use the unit during an electrical storm, as there is a remote chance of getting struck by lightning.
3. Do not climb on top of the gazebo. While the gazebo is made out of high-quality wood and is extremely durable, the gazebo is not meant to be used as a jungle gym. Thus, falling off of the gazebo while climbing on it can result in serious injury, possibly even death.
4. Do not attempt any repair without consulting the manufacturer first. Unauthorized repair attempts will void the manufacturer's warranty.

**Save this information.**

## CONTACT INFORMATION

For customer service, please contact your authorized dealer immediately. If you need additional information and/or assistance, please contact:

C.A.I. Customer Service Department  
1462 East Ninth Street  
Pomona, CA 91766  
Toll Free: 1-800-CAL-SPAS  
Fax: 1-909-629-3890

## WARRANTY INFORMATION

See your Cal Spas Creative Wood Designs dealer for a copy of the applicable warranty, details and any questions you may have regarding the warranty coverage on your gazebo.

### Warranty Limitations

The Limited Warranty is void if the gazebo has been subject to negligence, alteration, misuse, abuse, repairs by non- C.A.I. authorized representatives, acts of God and any other cases beyond the control of C.A.I. Examples of common acts invalidating this warranty include but are not limited to:

Use of the gazebo in a non-residential application.

Scratches caused by normal use.

Damage caused by extreme weather conditions. (hot, cold, etc.)

Damage caused by dirt, sand, and/or water damage.

Damage caused by continuous operation of the gazebo with either known or unknown problems.

Damage caused by direct sunlight.

Damage caused as a result of failure to follow the assembly instructions as defined in this Owner's Manual.

This Limited Warranty applies only to gazebos normally used for personal, family, or household purposes.

This Limited Warranty specifically excludes commercial gazebos.

### Warranty Exclusions

C.A.I. warrants the gazebo from defects in material and workmanship for a period of 90 days from the original date of purchase.

**REMINDER: PLEASE DO NOT FORGET TO REGISTER YOUR NEW PRODUCT AT [WWW.CALSPAS.COM](http://WWW.CALSPAS.COM)**



## DELIVERY AND SET-UP

Please make a record of the following. It will be valuable if service is required.

Gazebo Model: \_\_\_\_\_

Gazebo Serial Number: \_\_\_\_\_

Date Purchased: \_\_\_\_\_

Date Installed: \_\_\_\_\_

Gazebo Dealer's Phone Number: \_\_\_\_\_

Gazebo Dealer's Address: \_\_\_\_\_

Most cities and counties require permits for exterior construction and electrical circuits. In addition, some communities have codes requiring residential barriers such as fencing and/or self-closing gates on property to prevent unsupervised access to the property by children under the age of 5. Your dealer can provide information on which permits may be required and how to obtain them prior to the delivery of your equipment.

### PLANNING THE BEST LOCATION FOR YOUR GAZEBO

Here are some of the things that you will need to consider when determining where to locate your new gazebo.

#### How Will You Use Your Gazebo?

How you intend to use your gazebo will help you determine where you should position it. For example, will you use your gazebo for recreational purposes? If your gazebo is mainly used for family functions, be sure to leave plenty of room around it for activity. In any case dealing in how it is to be used, you'll probably want to create a specific mood around it.

#### Consider Your Privacy

In a cold- weather climate, bare trees won't provide much privacy. Think of your gazebo's surroundings during all seasons to determine your best privacy options. Consider the view of your neighbors as well, when you plan the location of your gazebo.

#### Provide A View With Your Gazebo

Think about the direction you will be facing when sitting in your gazebo. Do you have a special landscaped area in your yard that you find enjoyable? Perhaps there is an area that catches a soothing breeze during the day and lovely sunset in the evening. Consider these things when you plan your location.

## PREPARING A GOOD FOUNDATION

Your gazebo needs a solid and level foundation. The area that it sits on must be able to support the weight of the gazebo and the occupants who use it. If the foundation is inadequate, it may shift or settle after the gazebo is in place, causing stress that could alter the structures figure and possibly split the wooden joints.

**NOTE:** Damage caused by inadequate or improper foundation support is not covered by the warranty. It is the responsibility of the gazebo owner to provide a proper foundation for the gazebo.

Place the gazebo on an elevated foundation (preferably a 3" concrete slab).

\* If you are installing your gazebo on an elevated wood deck or other structure, it is highly recommended that you consult a structural engineer or contractor to ensure the structure will support the weight.

\* It is strongly recommended that a qualified, licensed contractor prepare the foundation for your gazebo.

## Your Cal Spas Creative Wood Designs Retailer Can Help You With Foundations And More

Your retailer has a wealth of information and experience about how to get the most out of your gazebo. Your gazebo retailer also has a full line of accessories that are engineered to compliment your gazebo.

**NOTE:** It is strongly advised that you have a licensed professional install the foundation for your new gazebo. It is imperative that the foundation is level, as any damage that occurs due to an uneven foundation is not covered by the warranty.

## Size Specifications

<u>Model</u>	<u>Length</u>	<u>Width</u>
Frontier Gazebo	8'	8'
	10'	8'
	12'	8'
Cottage Gazebo	8'	8'
Cabana Gazebo	7'	7'
	7.5'	7.5'
	8'	8'
Northeast Gazebo	7.5'	7.5'
	8'	8'
Lattice Wall Gazebo	7'	7'
	7.5'	7.5'
	8'	8'
	12'	8'
	16'	8'
	10'	10'
	12'	10'
	16'	10'
12'	12'	

<u>Model</u>	<u>Length</u>	<u>Width</u>
Lattice Wall Gazebo (cont.)	12'	12'
	16'	12'
	10' (Octagon)	10'
	12' (Octagon)	12'
Plexi Wall Gazebo	7'	7'
	7.5'	7.5'
	8'	8'
	12'	8'
	16'	8'
	10'	10'
	12'	10'
	12'	12'
	16'	12'
	10' (Octagon)	10'
	12' (Octagon)	12'
	15' (Octagon)	15'
18' (Octagon)	18'	
Luxury Wall Gazebo	7'	7'
	7.5'	7.5'
	8'	8'
	12'	8'
	16'	8'
	10'	10'
	12'	10'
	16'	10'
	12'	12'
	16'	12'
<b>Savannah Wall Gazebo</b>	<b>12'</b>	<b>8'</b>
	<b>10'</b>	<b>10'</b>
	<b>12'</b>	<b>10'</b>
	<b>16'</b>	<b>10'</b>
	<b>12'</b>	<b>12'</b>
	<b>16'</b>	<b>12'</b>
	<b>10' (Octagon)</b>	<b>10'</b>
	<b>12' (Octagon)</b>	<b>12'</b>
<b>15' (Octagon)</b>	<b>15'</b>	
<b>18' (Octagon)</b>	<b>18'</b>	
Timberline Gazebo	12'	8'
	10'	10'
	12'	10'
	12'	12'
	16'	12'

<b><u>Model</u></b>	<b><u>Length</u></b>	<b><u>Width</u></b>
Lighthouse Gazebo	10'	10'
	12'	10'
	12'	12'
	16'	12'
Plantation Gazebo	10'	10'
	12'	10'
	12'	12'
	16'	12'
Chalet Gazebo	12'(Octagon)	12'
	14'(Octagon)	14'
	16'(Octagon)	16'
Victorian Gazebo	12'(Octagon)	12'
	14' (Octagon)	14'
	16' (Octagon)	16'

**NOTE:** The gazebo above that is listed in bold lettering is the gazebo that you purchased.

**NOTE:** For all gazebos, regardless of model, it is recommended that the foundation (concrete slab, railroad ties or pre-cast stepping stones) extend beyond the dimension of the gazebo. For example, if the gazebo you purchased is 12'x12', you will want your foundation to be 12.5'x12.5'. The reason for this is because it will be easier to maintain the area around the gazebo (mowing the lawn, edging, etc.) without damaging or scarring the gazebo. Also, in doing this, you will eliminate any potential problems, foundation-wise, in the future.

**NOTE:** This Owner's Manual applies to the various sizes that are included in the Savannah Gazebo line (Savannah Wall - 8'x12', 10'x10', 10'x12', 10'x16', 12'x12' and 12'x16'; Savannah Octagon - 10'x10, 12'x12', 15'x15' and 18'x18'). While the sizes will vary from gazebo to gazebo, the assembly instructions will be the same, unless otherwise noted.

## **Tools and Materials**

Utility Knife	25' Tape Measure
Cordless Drill	100' Extension Cord
1/8" Pilot Hole Drill Bit	1/2" Ratchet and Impact Drill
Electric Drill	9/16" Socket
Phillips-Head Drill Tips	1/2" Carbide Drill Bit (Masonry Bit)
Slotted-Head Drill Tips	Sandpaper (Various Grades)
Redwood Stain	Wood Putty
Gray Wash Stain	Rags

# Assembly Instructions

The following sections are broken into two parts: Octagon and Rectangle. These sections will tell you how to assembly your gazebo. If you have any questions, problems with material and/or parts, please contact your local retailer.

## Wall Panel Assembly - Octagon

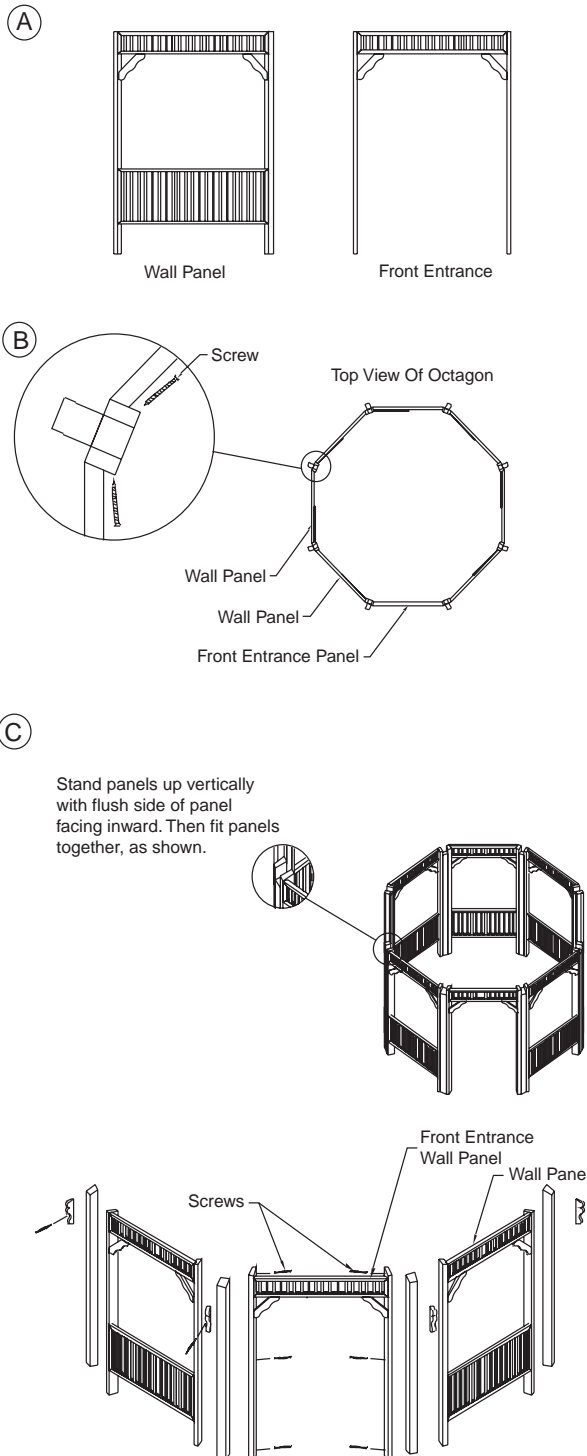

**NOTE:** The assembly instructions contained in this manual are for the Savannah Octagon Gazebo that measures 18'x18'. The assembly instructions will be the same for the 10'x10', 12'x12' and 14'x14' models. The only difference in the assembly of these three models is the amount of steps the owner must perform.

**NOTE:** All wall panels are pre-assembled at the factory before being shipped.

**NOTE:** Please follow the written steps in conjunction with the figures that are shown.

**NOTE:** The smooth side of each wall panel should be facing the inside of the gazebo.

**NOTE:** Check the parts list that came with your gazebo and make sure that all the parts are present.

1. Stand panels up vertically with the flush side of the panel facing inward (fit panels together as shown in **Figure 2A**).
2. Drill holes in all 2"x4" boards. The holes have already been drilled for the wall panels. Line up the holes and mark the 2"x4" and drill accordingly.
3. Insert the provided drywall screws into the pre-drilled holes and tighten with a phillips-head screwdriver (**Figure 2B**).
4. Repeat this step until wall panel assembly is complete (**Figure 2C**).
5. Using drywall screws to attach the corbels, as shown in **Figure 2C**.

**Figure 2.** Octagon Wall Panel Assembly

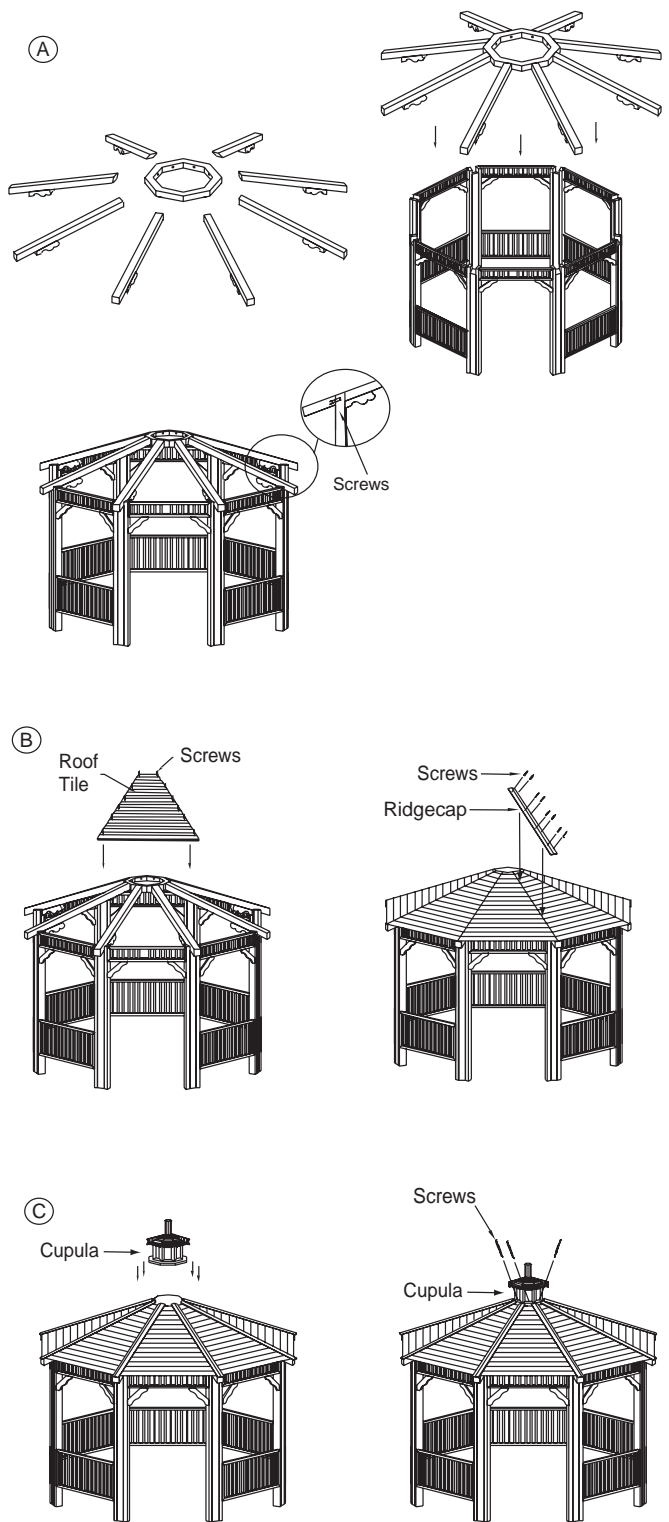

## COMPOSITION ROOF ASSEMBLY

**NOTE:** Check the parts list that came with your gazebo and make sure that all the parts are present. Also, please follow the written steps in conjunction with the figures that are shown.

1. Lay the 8-sided main roof support section flat on the ground. Referring the **Figure 3A**, attach the roof support boards to the 8-sided main roof support.
2. With the assistance of another person, place the roof frame assembly onto the assembled wall panels. There is a notch at each corner of the wall panel assembly (8 total). Place the roof frame in these notches and secure with drywall screws (**Figure 3A - inset**).
3. Place the 4-sided roof tiles (8 total) in the corresponding positions on the roof frame (narrow end on top, wide end on the bottom). Make sure each roof tile is centered on each support before securing. Secure using drywall screws (**Figure 3B**). Repeat this step until the roof frame is completely covered.
4. Attach each ridgecap with drywall screws (**Figure 3B**). Repeat this step until each roof joint is covered with a ridgecap.
5. With the aid of a ladder, place the cupula on top of the finished gazebo. Using the drywall screws, attach the cupula to the roof frame (**Figure 3C**).

**Figure 3.** Composition Roof Assembly

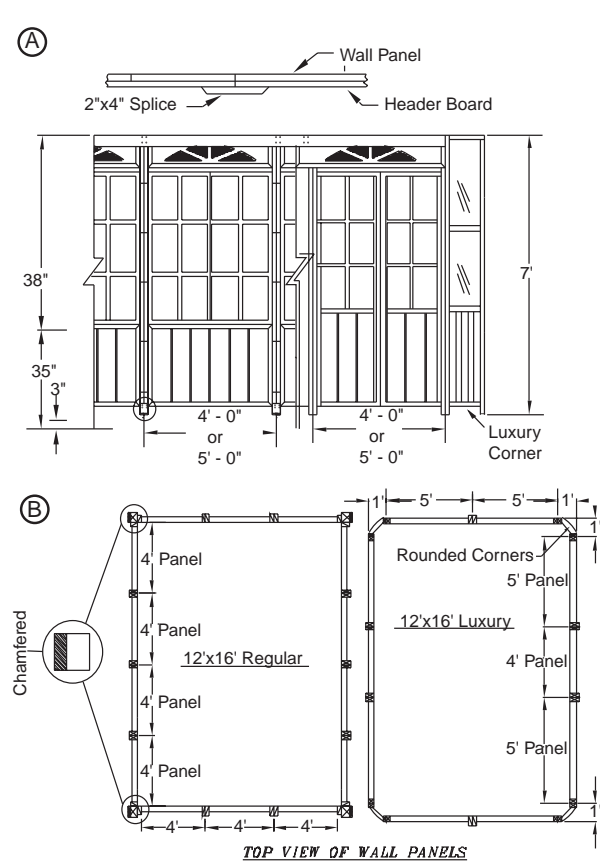

**Figure 4.** Rectangle Wall Panel Assembly

### Wall Panel Assembly - Rectangle

**NOTE:** The assembly instructions contained in this manual are for the Savannah Rectangle Gazebo that measures 12’x16’. The assembly instructions will be the same for the 8’x12’, 10’x10’, 10’x12’, 10’x16’ and 12’x12’ models. The only difference in the assembly of these five models is the amount of steps the owner must perform.

**NOTE:** All wall panels are pre-assembled at the factory before being shipped.

**NOTE:** Please follow the written steps in conjunction with the figures that are shown.

**NOTE:** The smooth side of each wall panel should be facing the inside of the gazebo.

**NOTE:** Check the parts list that came with your gazebo and make sure that all the parts are present.

1. Stand two panels up side by side. Attach the panels together using 5 drywall screws (**Figure 4A**).
2. At each wall seam, attach a 2”x4” Splice. This will tie-in and stabilize the walls (**Figure 4A**).
3. Repeat this step until all the panels are attached. **Figure 4B** will show you which order to go in.

**NOTE:** The rounded corners attach to the wall panels the same way, with 5 drywall screws. The owner must use care when securing the the wall panel and rounded corner together, as any damage incurred during assembly is not covered by the warranty.

**NOTE:** Rounded corners only come on the Luxury model.

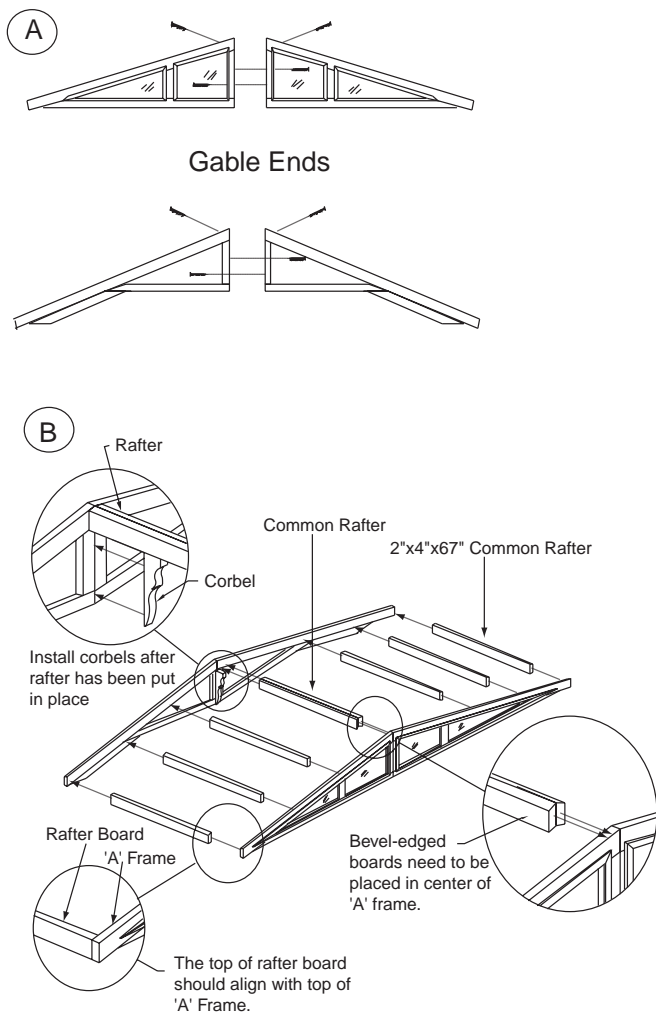

**Figure 5. Roof Frame Assembly**

### Roof Frame Assembly

When assembling the roof frame, it is recommended that you lay everything out and assemble it on a flat surface. It is also recommended that there be another person available when installing the roof frame on to the gazebo walls.

**NOTE:** Check the parts list that came with your gazebo and make sure that all the parts are present. Also, please follow the written steps in conjunction with the figures that are shown.

1. Take the gable ends and attach together using drywall screws (**Figure 5A**). Use the toe-in method for attachment.
2. Stand each gable end up and place about 6' apart.
3. Take two 2"x4"x67" common rafters and attach them to both gable ends (**Figure 5B - inset**). This will keep the roof frame assembly stable while completing the assembly process.
4. Attach two rafter boards at the ends of the gable roof assembly (**Figure 5B - inset**).
5. Take four common rafters and attach them to their corresponding locations (as shown in **Figure 5B**). Make sure that each common rafter is spaced equally apart.
7. Using the provided drywall screws, attach the corbels (**Figure 5B**).
8. Repeat these steps until the roof frame assembly is complete.



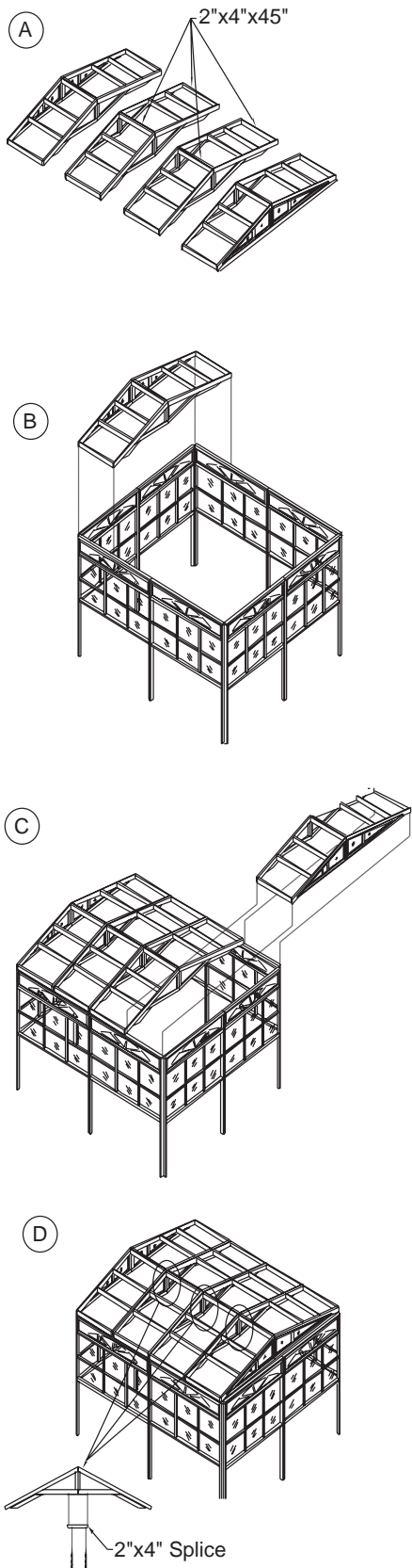
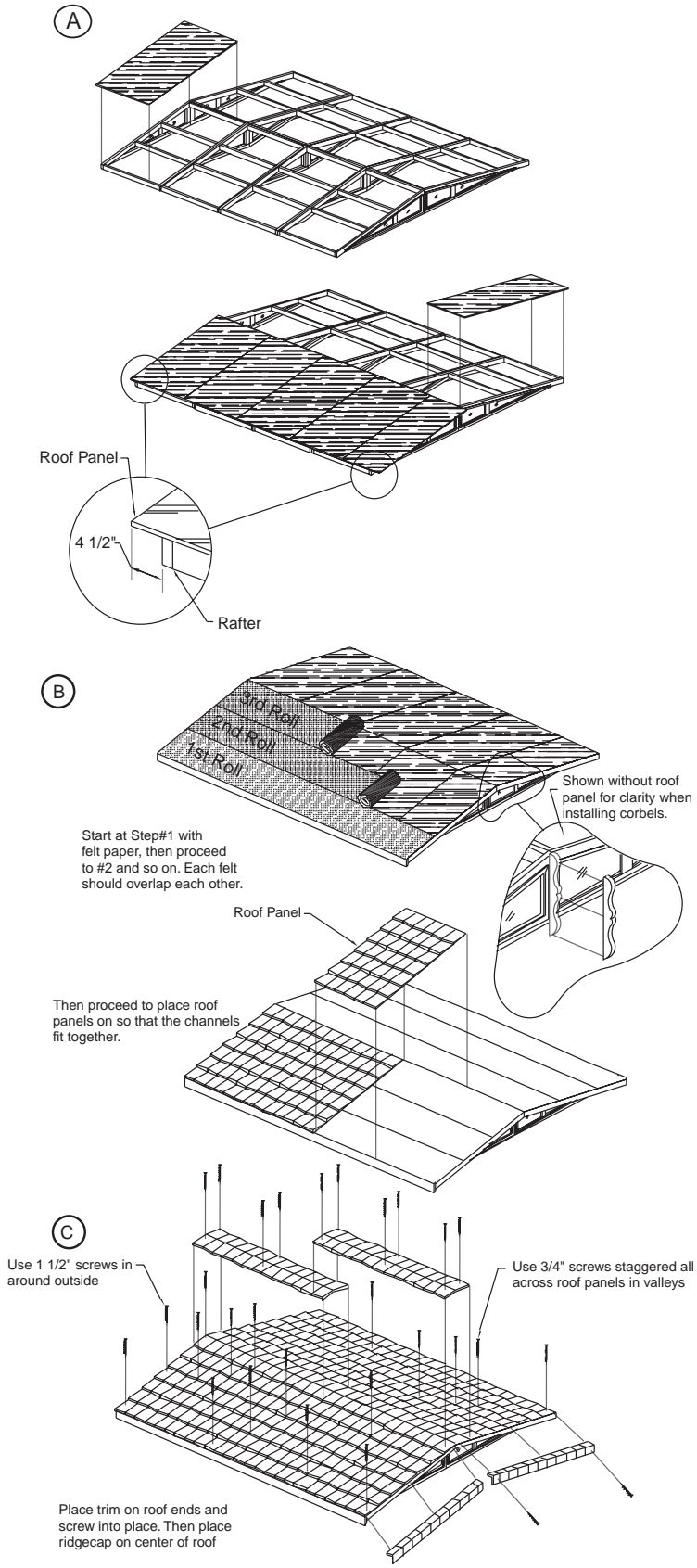

**Figure 6.** Roof Tile Installation

## Roof Frame Installation

**NOTE:** It is strongly recommended that you use a ladder for the final steps of the gazebo assembly.

1. Each roof section (4 total) must be set on top of the wall panel assembly and secured. When complete, tie in each roof section to the next roof section with drywall screws (**Figure 6A, 6B and 6C**).
2. Use 2"x4" splice to reinforce the underside of the roof sections. Secure using drywall screws (**Figure 6D**).



### Roof Panel Installation

**NOTE:** It is strongly recommended that you use a ladder for the final steps of the gazebo assembly.

**NOTE:** When installing the T1-11 plywood (grooved side facing down), the edge of the plywood should overhang the edge of the plexi-glass gable end 4 1/2".

1. Begin by placing one roof panel on to the roof section and secure using drywall screws. Repeat this step until all of the roof panels are secured.
2. Once the roof panels are secured, roll out the roll of felt paper along the bottom of the roof panels (Figure 7B). Make sure that each layer of felt paper overlaps the previous layer.
3. To help reinforce the gable ends, attach a corbel to each side, on the gable seam. Secure with drywall screws (Figure 7B - inset).
4. Place each roof tile panel on top of the roof. Do not secure yet. Line up tile panels and make sure that everything is flush, all the way around (Figure 7B) and that all the channels fit together.
5. Please use the following methods to secure the tile panels (Figure 7C):
  - a. Use 1 1/2" screws around the outside portion of the roof (outer-most edge).
  - b. Use 3/4" screws staggered all across the roof panels, in the valleys.
6. Attach the roof trim on each end of the roof using drywall screws (Figure 7C).
7. Place the ridgecap on top of the roof assembly and attach using drywall screws (Figure 7C).

**Figure 7. Roof Panel Installation**

---

## CLEANING, MAINTENANCE AND TROUBLESHOOTING

### Cleaning

Your gazebo was designed with low cleaning and maintenance in mind. We recommend that the gazebo be cleaned at least twice a month (or more, if needed). When cleaning your gazebo, cleaning solvents are not recommended. Using a sponge and water will be fine. For ground-in dirt and grime, please refer to the following section.

### Maintenance

Maintaining your gazebo will be an easy task. We recommend that every six months you should do an inspection of the wood on your gazebo. Take note of any deformities in the wood (i.e. cracking, peeling, dirt, grime, etc.). It is recommended that you spot sand these areas with 120-grit sandpaper. When complete, wipe these areas clean with a damp rag.

When dry, you must apply a coat of stain to the sanded area. Wipe the stained area clean and reapply until the sanded area matches the rest of the gazebo.

**NOTE:** An 8oz. can of stain will be supplied with each gazebo. To replace the can of stain, please contact your local Cal Enclosures dealer.

**NOTE:** On models that have plexi-glass windows, the use of a cheese cloth and warm water should be used. These windows are made of plexi-glass and do not hold up well under the abrasive conditions that many commercial cleaners generate.

## TROUBLESHOOTING PROCEDURES

**Q: Why will the windows on the gazebo not stay open/closed?**

**A:** This is most likely due to the fact that your foundation is not level. Foundations will most likely have a 1/4" pitch for drainage reasons. To rectify this problem, the gazebo must be shimmed on the low side. Using a standard level, shim the low side so that the gazebo is level.

**Q: Why won't the roof panels not sit correctly on the roof frame?**

**A:** Check the top plate on the top center frame and make sure it is level and installed correctly.

**Q: My roof and wall panels are lining up correctly and there are small gaps in the joint seams. Why is this?**

**A:** The main support post is not "plumb" (meaning vertically level). You must go back and make sure that the main support post is plumb. Also, you must make sure that each of your main support beams is "square" in relation to the main support post (meaning that there is a 90° angle when the main support post and the main support beam intersect).

## APPENDIX

The items that will be covered in this section will consist of the following:

Accessories

Part Numbers

Notes

In order for your retailer to expedite your order, for parts and accessories, it is recommended that you have the information that you attained in the Set-Up and Delivery section. Customer Service will want all this information for warranty purposes.

## ACCESSORIES

The following is a list of all the accessories that you can use with your Cal Spa Creative Wood Designs Gazebo. If you wish to order an accessory, feel free to contact your dealer with the desired part name and part number, or visit [www.calspas.com](http://www.calspas.com).

<b>Description</b>	<b>Size</b>	<b>Wood</b>	<b>Part Number</b>	
			<b>Cal Stone</b>	<b>Deluxe Stone</b>
Bar Top	11'	WOOD289	WOOD289CS	WOOD289DS
	80'	WOOD288	WOOD288CS	WOOD288DS
	75'	WOOD287	WOOD287CS	WOOD287DS
Round Corner		WOOD199	WOOD199CS	WOOD199DS
Storage Bench	11'	WOOD905	WOOD905CS	WOOD905DS
	80'	WOOD902	WOOD902CS	WOOD902DS
	75'	WOOD901	WOOD901CS	WOOD901DS
Crescent S/B		WOOD900	WOOD900CS	WOOD900DS
Bar Corbel		WOO270405060		
Bench Leg		WOO27405020		
Bar Stool		WOOD127	WOOD127CS	WOOD127DS
Surround Step	11'	WOOD296		
	80'	WOOD297		
	75'	WOOD298		
Crescent Step		WOOD214		
30' Step		WOOD107		
30" Storage Step w/Box		WOOD133		
5' Step		WOOD109		
5' Step Storage w/Box		WOOD134		
30" Step w/Handrail		WOOD107-2		
Round Planter		WOOD101		
Square Planter		WOOD100		
Crown Planter		WOOD189		
Octagon Planter		WOOD148		
Crescent Planter		WOOD168		
Bench	11'	WOOD923	WOOD923CS	WOOD923DS
	80'	WOOD922	WOOD922CS	WOOD922DS
	75'	WOOD921	WOOD921CS	WOOD921DS
Crescent Bench		WOOD920	WOOD920CS	WOOD920DS
Privacy Panel		WOOD183		
30" Step (3 tier)	30"	WOOD108		
30" Step (3 Tier with Handrail)	30"	WOOD108-2		
Towel/Wine Glass Rack	4'	WOOD113		
Towel/Wine Glass Rack	5'	WOOD113-5		
Wine Glass Hanger		WOOD114		
Towel Tree		WOOD169		
Kidzone Playhouse		KDZ100		

**12'X16' SAVANNAH WALL GABLE ROOF**

<b>Item Number</b>	<b>Description</b>	<b>Part Number</b>	<b>Quantity</b>
1	4' Savannah Wall Panel (High)	WOO27103320	7
2	4' Savannah Bar and Bench Top	WOO27103400	2
3	4' Savannah Wall w/out Bar	WOO27103480	1
4	4' Savannah Door Panel	WOO27105780	1
5	2"x4"x96" Header Boards M2	WOO27200020	2
6	2"x4"x72" Header Boards M1	WOO27200040	4
7	2"x4"x84 1/2" MIT.1 End 17°	WOO27210840	4
8	2"x4"x72" Corner Stabilizer M2	WOO27106160	6
9	2"x4x"10" Corbels (Inside)	WOO27210940	6
10	2"x4x"28" Corbels (Outside)	WOO27210920	1
11	84 1/2"x12' Gable w/Plexi (R)	WOO27209700	2
12	84 1/2"x12' Gable w/Plexi (L)	WOO27209860	2
13	2"x4"x98" w/ CHMF 17° Support	WOO27212460	2
14	2"x6"x110" Fascia Board	WOO27212500	4
15	4"x4"x84" Corner Connector	WOO27106100	4
16	2"x4"x98" Gable EMD Assembly Support	WOO27211600	6
17	4' Panel w/out Bench	WOO27103420	1
18	2"x3"x11" Savannah Bar Panel Corbel	WOO27103780	2
19	Bar Stool N/S	WOO27403300	2
20	Wine Glass Hanger	WOO27406900	1
21	5/8"x84 1/2"x48" T1-11 Plywood	WOO27209260	4
22	5/8"x84 1/2"x14" T1-11 Plywood	WOO27209260	2
23	56"x85" Roof Tile Section	WOO27212700	4
24	86" @ 90° Ridge Cap	WOO27212660	4
25	60" @ 45° Ridge Cap Top PLS	WOO27212540	2
26	8 x 2 1/2" Screw SQ Drive Drywall	HAR13201150	150
27	8 x 3" Screw SQ Drive Drywall	HAR13201140	25
28	#15 Felt Paper	WOO27904320	138 P/SF
29	8 x 1 5/8" Screw Phillips Drywall	HAR13200010	60
30	Roofing Nails	HAR13600090	0.1 P/5#

**18'X18' SAVANNAH OCTAGON**

<b>Item Number</b>	<b>Description</b>	<b>Part Number</b>	<b>Quantity</b>
1	78" Wall Panel	WOO27104720	7
2	78" Door Opening	WOO27106360	1
3	4"x6"x90" Post w/ 22 1/2" M1	WOO27110526	8
4	4"x6"x16" Corbels	WOO27110528	16
5	4"x4"x108" Hip Rafters	WOO27206300	8
6	18' Octagon Metal Roof Panel	WOO27215020	8
7	Top Center 36"	WOO27215580	1
8	2"x4"x103" Crown Molding	WOO27215560	8
9	Octagon Birdhouse	WOO27215140	1
10	8x2 1/2" Screw SQ Drive Drywall	HAR13201150	150
11	8x23" Screw SQ Drive Drywall	HAR13201140	25
12	3/8"x6" Hex Lags	HAR13200470	16

# NOTES



\$5.00



# 2004 Owner's Manual

## TIMBERLINE GAZEBO

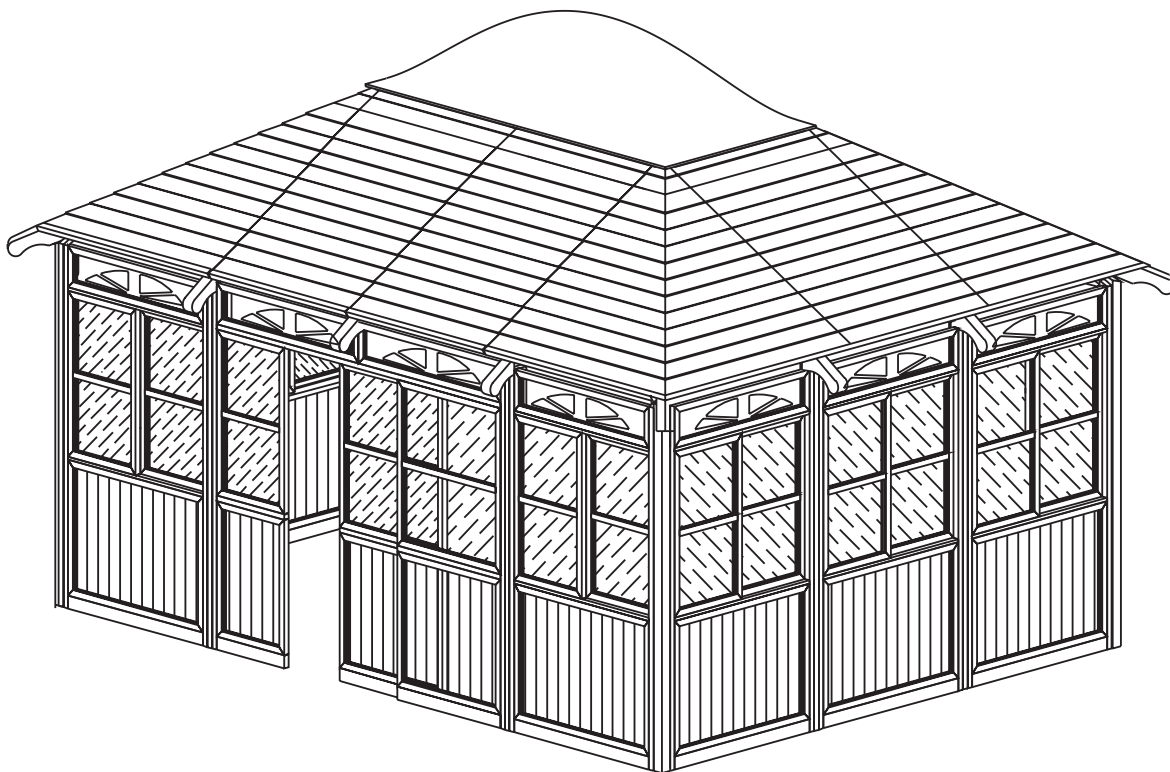

Duplication without written consent is strictly prohibited.

This Owner's Manual is for gazebos manufactured after January 1, 2004

Due to continuous improvement programs, all models, operation, and/or specifications are subject to change without prior notice.

LTR17000783

# Table of Contents

Benefits of Owning a Gazebo .....	2
Safety Instructions .....	3
Contact Information.....	4
Warranty Information .....	4
Set-up and Delivery .....	5
Assembly .....	9
Cleaning, Maintenance and Troubleshooting .....	13
Appendix .....	14
Accessories .....	15
Parts List.....	16
Notes.....	23

### BENEFITS OF OWNING A GAZEBO

Owning a gazebo allows you to have a wonderful place to unwind after a long day of work. It offers a place for you to socialize with family and friends. It offers great cover in the event that you purchase a bar-b-que and/or spa. Owning a gazebo can add character to your patio and/or yard. You can use a gazebo for whatever best suits your needs.

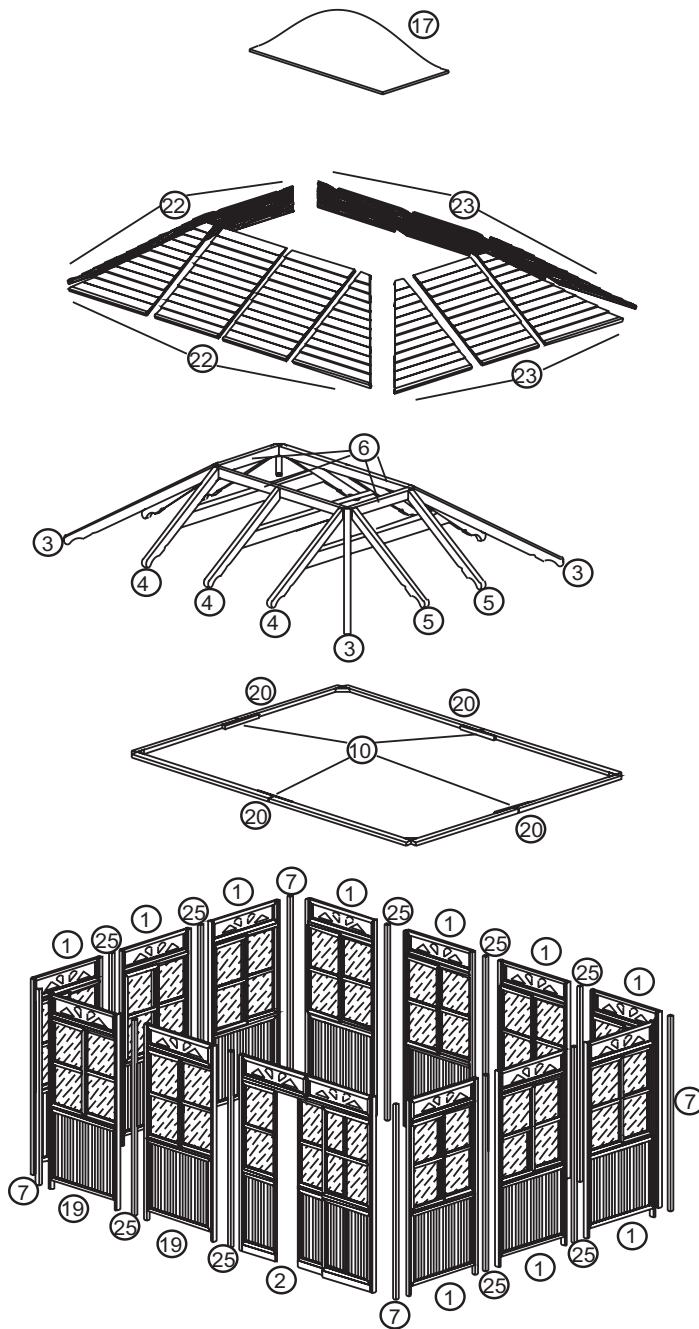

Figure 1. Timberline Gazebo

**NOTE:** Each item number listed above can be found in the “Parts List” section of this manual.

## **SAFETY INSTRUCTIONS**

### **Carefully read and follow all safety instructions.**

1. When installing and assembling your gazebo, it is recommended that 2 or more people be involved.
2. Do not use the unit during an electrical storm. as there is a remote chance of getting struck by lightening.
3. Do not climb on top of the gazebo. While the gazebo is made out of high-quality wood and is extremely durable, the gazebo is not meant to be used as a jungle gym. Thus, falling off of the gazebo while climbing on it can result in serious injury, possibly even death.
4. Do not attempt any repair without consulting the manufacturer first. Unauthorized repair attempts will void the manufacturer's warranty.

**Save this information.**

## CONTACT INFORMATION

For customer service, please contact your authorized dealer immediately. If you need additional information and/or assistance, please contact:

C.A.I. Customer Service Department  
1462 East Ninth Street  
Pomona, CA 91766  
Toll Free: 1-800-CAL-SPAS  
Fax: 1-909-629-3890

## WARRANTY INFORMATION

See your Cal Spas Creative Wood Designs dealer for a copy of the applicable warranty, details and any questions you may have regarding the warranty coverage on your gazebo.

### Warranty Limitations

The Limited Warranty is void if the gazebo has been subject to negligence, alteration, misuse, abuse, repairs by non- C.A.I. authorized representatives, acts of God and any other cases beyond the control of C.A.I. Examples of common acts invalidating this warranty include but are not limited to:

Use of the gazebo in a non-residential application.

Scratches caused by normal use.

Damage caused by extreme weather conditions. (hot, cold, etc.)

Damage caused by dirt, sand, and/or water damage.

Damage caused by continuous operation of the gazebo with either known or unknown problems.

Damage caused by direct sunlight.

Damage caused as a result of failure to follow the assembly instructions as defined in this Owner's Manual.

This Limited Warranty applies only to gazebos normally used for personal, family, or household purposes.

This Limited Warranty specifically excludes commercial gazebos.

### Warranty Exclusions

C.A.I. warrants the gazebo from defects in material and workmanship for a period of 90 days from the original date of purchase.

**REMINDER: PLEASE DO NOT FORGET TO REGISTER YOUR NEW PRODUCT AT [WWW.CALSPAS.COM](http://WWW.CALSPAS.COM)**

## DELIVERY AND SET-UP

Please make a record of the following. It will be valuable if service is required.

Gazebo Model: \_\_\_\_\_

Gazebo Serial Number: \_\_\_\_\_

Date Purchased: \_\_\_\_\_

Date Installed: \_\_\_\_\_

Gazebo Dealer's Phone Number: \_\_\_\_\_

Gazebo Dealer's Address: \_\_\_\_\_

Most cities and counties require permits for exterior construction and electrical circuits. In addition, some communities have codes requiring residential barriers such as fencing and/or self-closing gates on property to prevent unsupervised access to the property by children under the age of 5. Your dealer can provide information on which permits may be required and how to obtain them prior to the delivery of your equipment.

## PLANNING THE BEST LOCATION FOR YOUR GAZEBO

Here are some of the things that you will need to consider when determining where to locate your new gazebo.

### How Will You Use Your Gazebo?

How you intend to use your gazebo will help you determine where you should position it. For example, will you use your gazebo for recreational purposes? If your gazebo is mainly used for family functions, be sure to leave plenty of room around it for activity. In any case dealing in how it is to be used, you'll probably want to create a specific mood around it.

### Consider Your Privacy

In a cold- weather climate, bare trees won't provide much privacy. Think of your gazebos surroundings during all seasons to determine your best privacy options. Consider the view of your neighbors as well, when you plan the location of your gazebo.

### Provide A View With Your Gazebo

Think about the direction you will be facing when sitting in your gazebo. Do you have a special landscaped area in your yard that you find enjoyable? Perhaps there is an area that catches a soothing breeze during the day and lovely sunset in the evening. Consider these things when you plan your location.

## PREPARING A GOOD FOUNDATION

Your gazebo needs a solid and level foundation. The area that it sits on must be able to support the weight of the gazebo and the occupants who use it. If the foundation is inadequate, it may shift or settle after the gazebo is in place, causing stress that could alter the structures figure and possibly split the wooden joints.

**NOTE:** Damage caused by inadequate or improper foundation support is not covered by the warranty. It is the responsibility of the gazebo owner to provide a proper foundation for the gazebo.

Place the gazebo on an elevated foundation (preferably a 3” concrete slab).

- \* If you are installing your gazebo on an elevated wood deck or other structure, it is highly recommended that you consult a structural engineer or contractor to ensure the structure will support the weight.
- \* It is strongly recommended that a qualified, licensed contractor prepare the foundation for your gazebo.

## Your Cal Spas Creative Wood Designs Retailer Can Help You With Foundations And More

Your retailer has a wealth of information and experience about how to get the most out of your gazebo. Your gazebo retailer also has a full line of accessories that are engineered to compliment your gazebo.

**NOTE:** It is strongly advised that you have a licensed professional install the foundation for your new gazebo. It is imperative that the foundation is level, as any damage that occurs due to an uneven foundation is not covered by the warranty.

## Size Specifications

<u>Model</u>	<u>Length</u>	<u>Width</u>
Frontier Gazebo	8'	8'
	10'	8'
	12'	8'
Cottage Gazebo	8'	8'
Cabana Gazebo	7'	7'
	7.5'	7.5'
	8'	8'
Northeast Gazebo	7.5'	7.5'
	8'	8'
Lattice Wall Gazebo	7'	7'
	7.5'	7.5'
	8'	8'
	12'	8'
	16'	8'
	10'	10'
	12'	10'
	16'	10'
	12'	12'

<b><u>Model</u></b>	<b><u>Length</u></b>	<b><u>Width</u></b>
Lattice Wall Gazebo (cont.)	12'	12'
	16'	12'
	10' (Octagon)	10'
	12' (Octagon)	12'
Plexi Wall Gazebo	7'	7'
	7.5'	7.5'
	8'	8'
	12'	8'
	16'	8'
	10'	10'
	12'	10'
	12'	12'
	16'	12'
	10' (Octagon)	10'
	12' (Octagon)	12'
	15' (Octagon)	15'
18' (Octagon)	18'	
Luxury Wall Gazebo	7'	7'
	7.5'	7.5'
	8'	8'
	12'	8'
	16'	8'
	10'	10'
	12'	10'
	16'	10'
	12'	12'
	16'	12'
Savannah Wall Gazebo	12'	8'
	10'	10'
	12'	10'
	16'	10'
	12'	12'
	16'	12'
	10' (Octagon)	10'
	12' (Octagon)	12'
15' (Octagon)	15'	
18' (Octagon)	18'	
<b>Timberline Gazebo</b>	<b>12'</b>	<b>8'</b>
	<b>10'</b>	<b>10'</b>
	<b>12'</b>	<b>10'</b>
	<b>12'</b>	<b>12'</b>
	<b>16'</b>	<b>12'</b>



<b><u>Model</u></b>	<b><u>Length</u></b>	<b><u>Width</u></b>
Lighthouse Gazebo	10'	10'
	12'	10'
	12'	12'
	16'	12'
Plantation Gazebo	10'	10'
	12'	10'
	12'	12'
	16'	12'
Chalet Gazebo	12'(Octagon)	12'
	14'(Octagon)	14'
	16'(Octagon)	16'
Victorian Gazebo	12'(Octagon)	12'
	14' (Octagon)	14'
	16' (Octagon)	16'

**NOTE:** The gazebo above that is listed in bold lettering is the gazebo that you purchased.

**NOTE:** For all gazebos, regardless of model, it is recommended that the foundation (concrete slab, railroad ties or pre-cast stepping stones) extend beyond the dimension of the gazebo. For example, if the gazebo you purchased is 12'x12', you will want your foundation to be 12.5'x12.5'. The reason for this is because it will be easier to maintain the area around the gazebo (mowing the lawn, edging, etc.) without damaging or scarring the gazebo. Also, in doing this, you will eliminate any potential problems, foundation-wise, in the future.

**NOTE:** This Owner's Manual applies to the various sizes that are included in the Timberline Gazebo line (8'x12', 10'x10', 10'x12', 12'x12' and 12'x16'). While the sizes will vary from gazebo to gazebo, the assembly instructions will be the same, unless otherwise noted.

## **Tools and Materials**

Utility Knife	25' Tape Measure
Cordless Drill	100' Extension Cord
1/8" Pilot Hole Drill Bit	1/2" Ratchet and Impact Drill
Electric Drill	9/16" Socket
Phillips-Head Drill Tips	1/2" Carbide Drill Bit (Masonry Bit)
Slotted-Head Drill Tips	Sandpaper (Various Grades)
Redwood Stain	Wood Putty
Gray Wash Stain	Rags

# ASSEMBLY INSTRUCTIONS

The following sections will tell you how to assembly your gazebo. If you have any questions, problems with material and/or parts, please contact your local retailer.

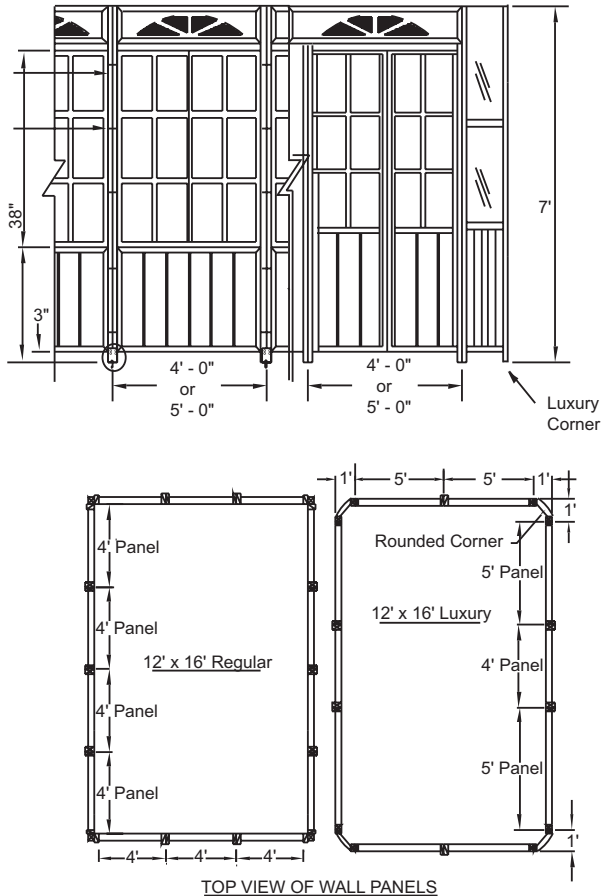

**Figure 2.** Wall Panel Assembly

## Wall Panel Assembly

**NOTE:** Please follow the written steps in conjunction with the figures that are shown.

1. Stand two panels up side by side. Attach the panels together using 5 drywall screws (**Figure 2A**).
2. Repeat this step until all the panels are attached. **Figure 2B** will show you which order to go in.

**NOTE:** The rounded corners attach to the wall panels the same way, with 5 drywall screws. The owner must use care when securing the the wall panel and rounded corner together, as any damage incurred during assembly is not covered by the warranty.

**NOTE:** Use care when attaching the sides and corners. Be sure that the windows do not come in contact with the mounting screws.

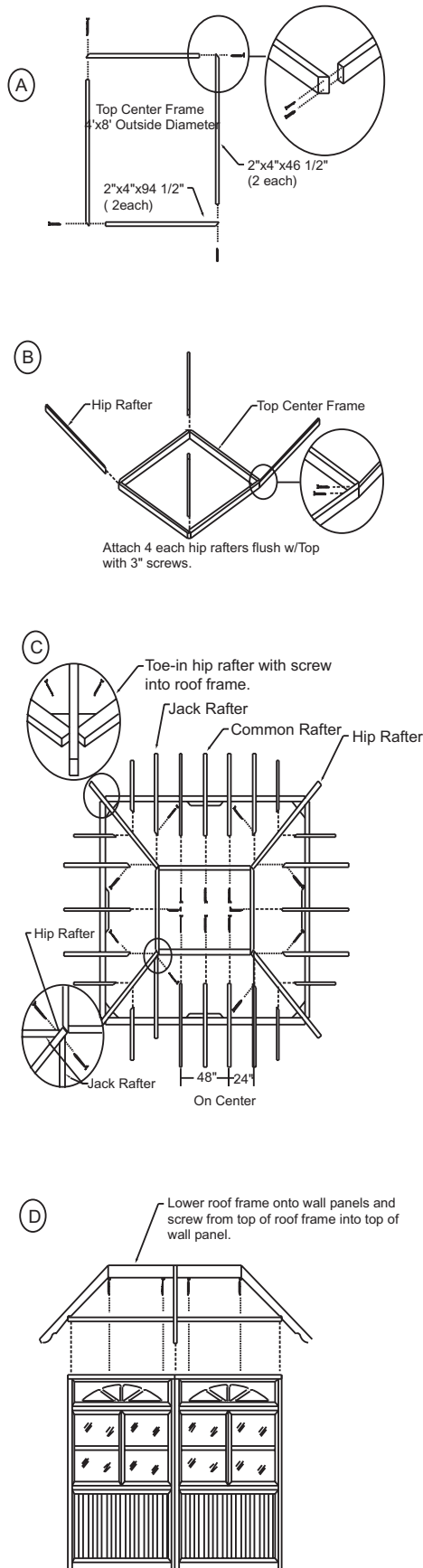

### Roof Frame Assembly

When assembling the roof frame, it is recommended that you lay everything out and assemble it on a flat surface. It is also recommended that there be another person available when installing the roof frame on to the gazebo walls.

**NOTE:** Check the parts list that came with your gazebo and make sure that all the parts are present. Also, please follow the written steps in conjunction with the figures that are shown.

1. Take two 2"x4"x46 1/2" pieces of wood and two 2"x4"x94 1/2" pieces of wood and lay them out on the ground (**Figure 3A**), in effect making a rectangle.
2. Use the provided drywall screws to attach all the pieces together. When complete, the outside diameter should roughly measure 7'x3'.
3. Place corner stabilizer (4 each) and attach in each corner (**Figure 3C**) using drywall screws.
4. Attach each corner together with the provided screws, making sure to keep the 45° corners pointing outward (**Figure 3B - insert**). This is the top center frame.
5. Take the hip rafters (4 each) and attach them to each corner of the top center frame. Make sure that the 45° corner matches the 45° end on the hip rafters (**Figure 3B**).
6. Take 4 common rafters and attach them to the middle of each side of the top center frame assembly (**Figure 3C**). Use the toe-in method (see inset).
7. With the common rafters now installed, attach the the remaining jack rafters using the toe-in method. Make sure that each jack rafter is spaced evenly apart. This will ensure sufficient anchoring points for the roof panels.
8. **Figure 3D** shows what the roof frame will look like when it is completed.

**NOTE:** It is recommended that you have an assistant for the following step.

9. Place the assembled roof section on top of the wall panel assembly. Anchor the roof section by using drywall screws (**Figure 3D**).

**Figure 3. Roof Frame Assembly**

### Roof Panel Installation

**NOTE:** It is strongly recommended that you use a ladder for the final steps of the gazebo assembly.

1. Prior to installing the roof panels, a center line must be drawn on the top side of each rafter (**Figure 4A**).
2. Place each roof panel in place (with the edge being flush with the center line) and mount using drywall screws (**Figure 4B**).
3. Using the provided hardware, mount the dome bracket (**Figure 4C**).
4. Use 2 1/2" drywall screws to mount all ridge caps (**Figure 4C**).
5. Set the roof assembly onto the wall panel assembly and attach using drywall screws.

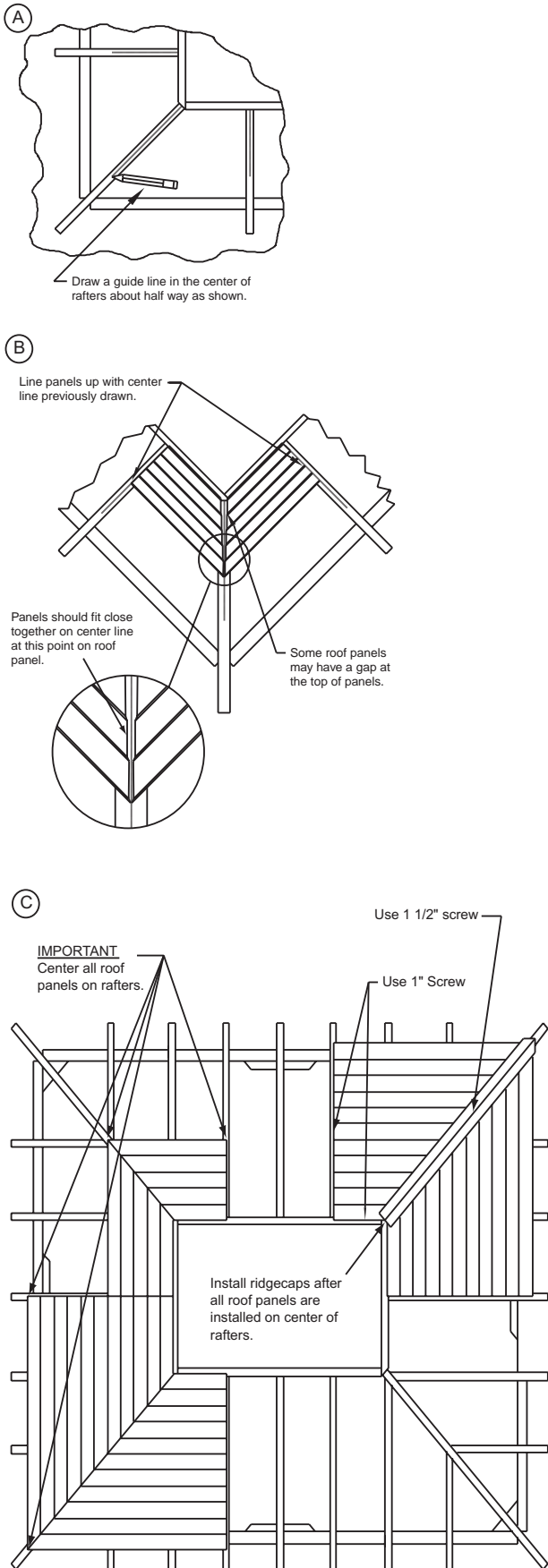
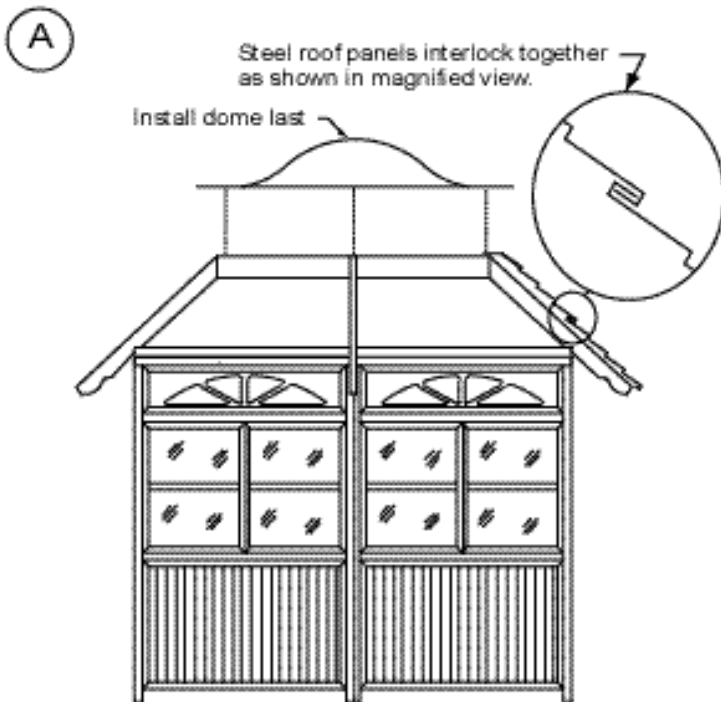

Figure 4. Roof Panel Installation



### Dome Installation

**NOTE:** The final steps of the gazebo assembly will require the use of a ladder.

1. Set the dome assembly into the dome housing (**Figure 5A**).
2. From the inside the gazebo secure the dome assembly to the roof assembly using the dome brackets and drywall screws (**Figure 5B**). There will be four dome brackets that will connect to each side of the dome frame.

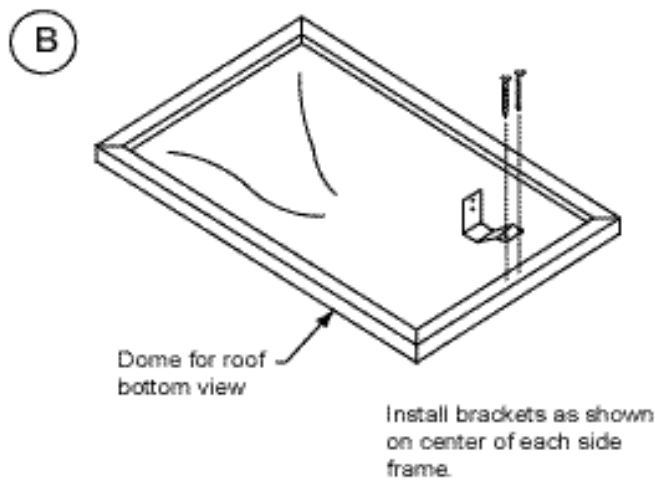

**Figure 5.** Dome Installation

# CLEANING, MAINTENANCE AND TROUBLESHOOTING

## Cleaning

Your gazebo was designed with low cleaning and maintenance in mind. We recommend that the gazebo be cleaned at least twice a month (or more, if needed). When cleaning your gazebo, cleaning solvents are not recommended. Using a sponge and water will be fine. For ground-in dirt and grime, please refer to the following section.

## Maintenance

Maintaining your gazebo will be an easy task. We recommend that every six months you should do an inspection of the wood on your gazebo. Take note of any deformities in the wood (i.e. cracking, peeling, dirt, grime, etc.). It is recommended that you spot sand these areas with 120-grit sandpaper. When complete, wipe these areas clean with a damp rag.

When dry, you must apply a coat of stain to the sanded area. Wipe the stained area clean and reapply until the sanded area matches the rest of the gazebo.

**NOTE:** An 8oz. can of stain will be supplied with each gazebo. To replace the can of stain, please contact your local Cal Enclosures dealer.

**NOTE:** On models that have plexi-glass windows, the use of a cheese cloth and warm water should be used. These windows are made of plexi-glass and do not hold up well under the abrasive conditions that many commercial cleaners generate.

## TROUBLESHOOTING PROCEDURES

**Q: Why will the windows on the gazebo not stay open/closed?**

**A:** This is most likely due to the fact that your foundation is not level. Foundations will most likely have a 1/4" pitch for drainage reasons. To rectify this problem, the gazebo must be shimmed on the low side. Using a standard level, shim the low side so that the gazebo is level.

**Q: Why won't the roof panels not sit correctly on the roof frame?**

**A:** Check the top plate on the top center frame and make sure it is level and installed correctly.

**Q: My roof and wall panels are lining up correctly and there are small gaps in the joint seams. Why is this?**

**A:** The main support post is not "plumb" (meaning vertically level). You must go back and make sure that the main support post is plumb. Also, you must make sure that each of your main support beams is "square" in relation to the main support post (meaning that there is a 90° angle when the main support post and the main support beam intersect).

## APPENDIX

The items that will be covered in this section will consist of the following:

Accessories

Part Numbers

Notes

In order for your retailer to expedite your order, for parts and accessories, it is recommended that you have the information that you attained in the Set-Up and Delivery section. Customer Service will want all this information for warranty purposes.

## ACCESSORIES

The following is a list of all the accessories that you can use with your Cal Spa Creative Wood Designs Gazebo. If you wish to order an accessory, feel free to contact your dealer with the desired part name and part number, or visit [www.calspas.com](http://www.calspas.com).

<b>Description</b>	<b>Size</b>	<b>Wood</b>	<b>Part Number</b>	
			<b>Cal Stone</b>	<b>Deluxe Stone</b>
Bar Top	11'	WOOD289	WOOD289CS	WOOD289DS
	80'	WOOD288	WOOD288CS	WOOD288DS
	75'	WOOD287	WOOD287CS	WOOD287DS
Round Corner		WOOD199	WOOD199CS	WOOD199DS
Storage Bench	11'	WOOD905	WOOD905CS	WOOD905DS
	80'	WOOD902	WOOD902CS	WOOD902DS
	75'	WOOD901	WOOD901CS	WOOD901DS
Crescent S/B		WOOD900	WOOD900CS	WOOD900DS
Bar Corbel		WOO270405060		
Bench Leg		WOO27405020		
Bar Stool		WOOD127	WOOD127CS	WOOD127DS
Surround Step	11'	WOOD296		
	80'	WOOD297		
	75'	WOOD298		
Crescent Step		WOOD214		
30' Step		WOOD107		
30" Storage Step w/Box		WOOD133		
5' Step		WOOD109		
5' Step Storage w/Box		WOOD134		
30" Step w/Handrail		WOOD107-2		
Round Planter		WOOD101		
Square Planter		WOOD100		
Crown Planter		WOOD189		
Octagon Planter		WOOD148		
Crescent Planter		WOOD168		
Bench	11'	WOOD923	WOOD923CS	WOOD923DS
	80'	WOOD922	WOOD922CS	WOOD922DS
	75'	WOOD921	WOOD921CS	WOOD921DS
Crescent Bench		WOOD920	WOOD920CS	WOOD920DS
Privacy Panel		WOOD183		
30" Step (3 tier)	30"	WOOD108		
30" Step (3 Tier with Handrail)	30"	WOOD108-2		
Towel/Wine Glass Rack	4'	WOOD113		
Towel/Wine Glass Rack	5'	WOOD113-5		
Wine Glass Hanger		WOOD114		
Towel Tree		WOOD169		
Kidzone Playhouse		KDZ100		



**8'x12' TIMBERLINE (METAL ROOF)**

<b>Item Number</b>	<b>Description</b>	<b>Part Number</b>	<b>Quantity</b>
1	4' Luxury Wall Panel Complete	WOO27102560	8
2	5' Luxury Door Complete	WOO27107460	1
3	3"x4"x55 3/4" Hip Rafters	WOO27213200	4
4	3"x4"x40 1/2" Common Rafters	WOO27213220	6
5	4"x4"x84" Corner Connector	WOO27106080	4
6	2"x3"x96" Header Boards	WOO27107720	2
7	3"x4"x93 3/4" M1	WOO27209000	2
8	3"x4"x45 3/4" M1 Top Center	WOO27209020	2
9	2"x3"x72" Header Board	WOO27107700	4
10	2"x4"x72" M2 Cross Ties	WOO27209140	2
11	2"x4"x6 1/2" Corner Stabilizer	WOO27200600	4
12	Coil Strap	HAR39000070	8 Ft.
13	8"x3" Screw SQ Drive Drywall	HAR13201140	25
14	8"x2 1/2" Screw SQ Drive Drywall	HAR13201150	125
15	3/8"x6" Hex Lags	HAR13200470	20
16	1/2"x2 3/4" Wedge Anchor ZP	HAR13900050	10
17	Gazebo Bracket	WOO27903780	10
18	54"x102" Dome w/Frame	WOO27211800	1
19	Timberline Dome Bracket	HAR13800030	4
20	8"x1" Roof Screw	HAR13200200	100
21	3" Luxury Wall Panel	WOO27102570	1
22	2"x4"x41" Common Rafter	WOO27200520	10
23	2"x2"x24" M2	WOO27106900	4
24	Corner Metal Panel #4 (L)	WOO27200720	4
25	Corner Metal Panel #4 (R)	WOO27200740	4
26	Center Metal Panel #6	WOO27200800	2
27	47 1/2" Molding Corner	HAR13900180	4
28	36" Molding Center NETA	HAR13900160	6
29	8"x1 1/2" Screw Molding	HAR13200050	35
30	8 oz can of spray paint		1
31	Registration Card		1
32	Warranty Card		1

**8'x12' TIMBERLINE (SOLID ROOF)**

<b>Item Number</b>	<b>Description</b>	<b>Part Number</b>	<b>Quantity</b>
1	4' Luxury Wall Panel Complete	WOO27102560	8
2	5' Luxury Door Complete	WOO27107460	1
3	3"x4"x55 3/4" Hip Rafters	WOO27213200	4
4	3"x4"x40 1/2" Common Rafters	WOO27213220	6
5	4"x4"x84" Corner Connector	WOO27106080	4
6	2"x3"x96" Header Boards	WOO27107720	2
7	3"x4"x93 3/4" M1	WOO27209000	2
8	3"x4"x45 3/4" M1 Top Center	WOO27209020	2
9	2"x3"x72" Header Board	WOO27107700	4
10	2"x4"x72" M2 Cross Ties	WOO27209140	2
11	2"x4"x6 1/2" Corner Stabilizer	WOO27200600	4
12	Coil Strap	HAR39000070	8 Ft.
13	8"x3" Screw SQ Drive Drywall	HAR13201140	25
14	8"x2 1/2" Screw SQ Drive Drywall	HAR13201150	125
15	3/8"x6" Hex Lags	HAR13200470	20
16	1/2"x2 3/4" Wedge Anchor ZP	HAR13900050	10
17	Gazebo Bracket	WOO27903780	10
18	54"x102" Dome w/Frame	WOO27211800	1
19	Timberline Dome Bracket	HAR13800030	4
20	8"x1" Roof Screw	HAR13200200	100
21	3" Luxury Wall Panel	WOO27102570	1
22	2"x2"x24" M2	WOO27208020	4
23	58"x41" Corner Roof Panel (R)	WOO27212880	4
24	58"x41" Corner Roof Panel (L)	WOO27212960	4
25	48"x41" Center Solid Panel	WOO27212980	2
26	2"x4"x60" Crown Molding w/CP	WOO27213520	4
27	2"x4"x43" Crown Molding w/CP	WOO27213540	6
28	8 oz can of spray paint		1
29	Registration Card		1
30	Warranty Card		

**10'x10' TIMBERLINE (METAL ROOF)**

<b>Item Number</b>	<b>Description</b>	<b>Part Number</b>	<b>Quantity</b>
1	5' Luxury Wall Panel Complete	WOO27102920	7
2	5' Luxury Door Complete	WOO27107460	1
3	3"x4"x91" Hip Rafter (TIMB)	WOO27207720	4
4	3"x4"x67" Common Rafter STD	WOO27208040	4
5	4"x4"x84" Corner Connector	WOO27106080	4
6	3"x4"x21 3/4" M1 Moon Roof Frame	WOO27209080	4
7	2"x3"x60" M1 Header Boards	WOO27107680	8
8	2"x4"x96" Cross Ties M1	WOO27211320	1
9	2"x2"x24" M2	WOO27106900	4
10	2"x4"x6 1/2" Corner Stabilizer	WOO27200600	4
11	12" Coil Strap	HAR13900070	8
12	8"x2 1/2" Screw SQ Drive Drywall	HAR13201150	150
13	8"x3" Screw SQ Drive Drywall	HAR13201140	25
14	3/8"x6" Hex Lags	HAR13200470	16
15	Gazebo Bracket	WOO27903780	8
16	8"x1" Metal Roof Screw	HAR13200200	100
17	1/2"x2 3/4" Wedge Anchor ZP	HAR13900050	8
18	30"x30" Dome w/ Frame	WOO27212100	1
19	2"x4"x67" Jack Rafter (L) No Slider	WOO27200640	4
20	2"x4"x67" Jack Rafter (R) No Slider	WOO27200620	4
21	2"x4"x43" Jack Rafter (L)	WOO27200660	4
22	2"x4"x43" Jack Rafter (R)	WOO27200580	4
23	#8 Metal Roof Panel (L) Top	WOO27200900	4
24	#8 Metal Roof Panel (L)Bottom	WOO27200920	4
25	#8 Metal Roof Panel (R) Top	WOO27200940	4
26	#8 Metal Roof Panel (R) Bottom	WOO27200960	4
27	82 3/4" Crown Molding Metal	HAR13900190	4
28	62" Crown Molding Metal	HAR13900070	4
29	6"x1 1/4" Phil Oval Screw 18.8	HAR13200240	60
30	8"x1 1/2" Metal Roof Screw	HAR13200050	35
31	Dome Bracket	HAR13800020	4

**10'x10' TIMBERLINE (SOLID ROOF)**

<b>Item Number</b>	<b>Description</b>	<b>Part Number</b>	<b>Quantity</b>
1	5' Luxury Wall Panel Complete	WOO27102920	7
2	5' Luxury Door Complete	WOO27107460	1
3	3"x4"x91" Hip Rafter (TIMB)	WOO27207720	4
4	3"x4"x67" Common Rafter STD	WOO27208040	4
5	4"x4"x84" Corner Connector	WOO27106080	4
6	3"x4"x21 3/4" M1 Moon Roof Frame	WOO27209080	4
7	2"x3"x60" M1 Header Boards	WOO27107680	8
8	2"x4"x96" Cross Ties M1	WOO27211320	1
9	2"x2"x24" M2	WOO27106900	4
10	2"x4"x6 1/2" Corner Stabilizer	WOO27200600	4
11	12" Coil Strap	HAR13900070	8
13	8"x2 1/2" Screw SQ Drive Drywall	HAR13201150	150
14	8"x3" Screw SQ Drive Drywall	HAR13201140	25
15	3/8"x6" Hex Lags	HAR13200470	16
16	Gazebo Bracket	WOO27903780	8
17	8"x1" Metal Roof Screw	HAR13200200	100
18	1/2"x2 3/4" Wedge Anchor ZP	HAR13900050	8
19	30"x30" Dome w/ Frame	WOO27212100	1
20	36"x84" Deck Assembly	WOO27302820	2
21	36"x36" Deck Assembly	WOO27303080	1
22	66"x70"x5' Solid Roof Panel (R)	WOO27203160	4
23	66"x70"x5' Solid Roof Panel (L)	WOO27203340	4
24	2"x4"x86" Crown Molding	WOO27208220	4
25	2"x4"x64" Crown Molding	WOO27208280	4
26	Timberline Dome Bracket	HAR13800030	4

**10'x12' TIMBERLINE (METAL ROOF)**

<b>Item Number</b>	<b>Description</b>	<b>Part Number</b>	<b>Quantity</b>
1	5' Luxury Wall Panel Complete	WOO27102920	4
2	4' Luxury Wall Panel Complete	WOO27102560	4
3	5' Luxury Door Complete	WOO27107460	1
4	3"x4"x91" Hip Rafter (Timberline)	WOO27207720	4
5	3"x4"x67" Jack Rafter (L)	WOO27208060	2
6	3"x4"x67" Jack Rafter (R)	WOO27208080	2
7	3"x4"x67" Common Rafter	WOO27208040	2
8	4"x4"x84" Corner Connector	WOO27106080	4
9	2"x3"x72" Header Boards	WOO27107700	4
10	2"x3"x60" Header Boards	WOO27107680	4
11	2"x4"x96" Cross Ties	WOO27211320	2
12	3"x4"x21 3/4" M1	WOO27209080	2
13	3"x4"x45 3/4" M1 Top Center	WOO27209020	2
14	2"x2"x24" M2	WOO27106900	4
15	2"x4"x6 1/2" Corner Stabilizer	WOO27200600	4
16	1/2"x2 3/4"x Wedge Anchor ZP	HAR13900050	10
17	Gazebo Bracket	WOO27903780	10
18	Coil Strap	HAR13900070	4
19	30"x54" Dome w/ Frame	WOO27211940	1
20	3' Luxury Wall Panel	WOO27102570	1
21	2"x4"x67" Common Rafter, No Slider	WOO27200480	2
22	2"x4"x43" Jack Rafter (R)	WOO27200580	4
23	2"x4"x43" Jack Rafter (L)	WOO27200660	4
24	2"x4"x67" Jack Rafter (R), No Slider	WOO27200620	2
25	2"x4"x67" Jack Rafter (L), No Slider	WOO27200640	2
26	#7 Top Metal Roof Panel (L)	WOO27200820	2
27	#7 Bottom Metal Roof Panel (L)	WOO27200840	2
28	#7 Top Metal Roof Panel (R)	WOO27200860	2
29	#7 Bottom Metal Roof Panel (R)	WOO27200880	2
30	#8 Metal Roof Top Panel (L)	WOO27200900	2
31	#8 Bottom Metal Roof Panel (L)	WOO27200920	2
32	#8 Top Metal Roof Panel (R)	WOO27200940	2
33	#8 Bottom Metal Roof Panel (R)	WOO27200960	2
34	62" Metal Molding	HAR13900180	4
35	82 3/4" Metal Molding	HAR13900190	4
36	3/8"x6" Hex Lags	HAR13200470	20
37	Dome Bracket	WOO27211940	4

**10'x12' TIMBERLINE (SOLID ROOF)**

<b>Item Number</b>	<b>Description</b>	<b>Part Number</b>	<b>Quantity</b>
1	5' Luxury Wall Panel Complete	WOO27102920	4
2	4' Luxury Wall Panel Complete	WOO27102560	4
3	5' Luxury Door Complete	WOO27107460	1
4	3"x4"x91" Hip Rafter (Timberline)	WOO27207720	4
5	3"x4"x67" Jack Rafter (L)	WOO27208060	2
6	3"x4"x67" Jack Rafter (R)	WOO27208080	2
7	3"x4"x67" Common Rafter	WOO27208040	2
8	4"x4"x84" Corner Connector	WOO27106080	4
9	2"x3"x72" Header Boards	WOO27107700	4
10	2"x3"x60" Header Boards	WOO27107680	4
11	2"x4"x96" Cross Ties	WOO27211320	2
12	3"x4"x21 3/4" M1	WOO27209080	2
13	3"x4"x45 3/4" M1 Top Center	WOO27209020	2
14	2"x2"x24" M2	WOO27106900	4
15	2"x4"x6 1/2" Corner Stabilizer	WOO27200600	4
16	1/2"x2 3/4"x Wedge Anchor ZP	HAR13900050	10
17	Gazebo Bracket	WOO27903780	10
18	Coil Strap	HAR13900070	4
19	30"x54" Dome w/ Frame	WOO27211940	1
20	3' Luxury Wall Panel	WOO27102570	1
21	66"x70"x 5' Solid Roof Panel (R)	WOO27203160	2
22	66"x70"x 5' Solid Roof Panel (L)	WOO27203340	2
23	58"x66"4' Solid Roof Panel (R)	WOO27201720	2
24	58"x66"4' Solid Roof Panel (L)	WOO27201720	2
25	48"x66" Center Wood Panel	WOO27204460	2
26	2"x4"x86" Crown Molding	WOO27208220	4
27	2"x4"x64" Crown Molding	WOO27208280	6
28	Timberline Dome Bracket	HAR13800030	4
29	8"x1" Screw	HAR13200200	25

**12'x12' TIMBERLINE (SOLID ROOF)**

<b>Item Number</b>	<b>Description</b>	<b>Part Number</b>	<b>Quantity</b>
1	4' Luxury Wall Panel Complete	WOO27102560	10
2	5' Luxury Door Complete	WOO27107460	1
3	3"x4"x91" Hip Rafter (TIMB)	WOO27207720	4
4	3"x4"x67" Jack Rafter (L)	WOO27208060	4
5	3"x4"x67" Jack Rafter (R)	WOO27208080	4
6	3"x4"x45 3/4" M1 Top Center	WOO27209020	4
7	4"x4"x84" Corner Connector	WOO27106080	4
8	2"x4"x60" Cross Ties M1	WOO27200140	4
9	1"x4"x18" M2 Cross Ties	WOO27209180	4
10	2"x2"x24" M2	WOO27106900	4
11	Coil Strap	HAR13900070	8
12	8"x2 1/2" Screw SQ Drive Drywall	HAR13201150	150
13	8"x3" Screw SQ Drive Drywall	HAR13201140	25
14	3/8"x6" Hex Lags	HAR13200470	20
15	Gazebo Bracket	WOO27903780	12
16	1/2"x2 3/4" Wedge Anchor ZP	HAR13900050	12
17	54"x54" Dome w/ Frame	WOO27211740	1
18	8"x1" Screw	HAR13200200	25
19	3' Luxury Wall Panel	WOO27102570	1
20	2"x3"x72" Header Boards	WOO27107720	8
21	2"x4"x6 1/2" Corner Stabilizer M2	WOO27200600	4
22	58"x66" 4' Solid Roof Panel (R)	WOO27201720	4
23	58"x66" 4' Solid Roof Panel (L)	WOO27202100	4
24	48"x66" Center Wood Panel	WOO27204460	4
25	2"x4"x86" Crown Molding	WOO27208220	4
26	2"x4"x64" Crown Molding	WOO27208280	8
27	Timberline Bracket Dome	HAR13800030	4

# NOTES



\$5.00



# 2004 Owner's Manual

## LIGHTHOUSE GAZEBO

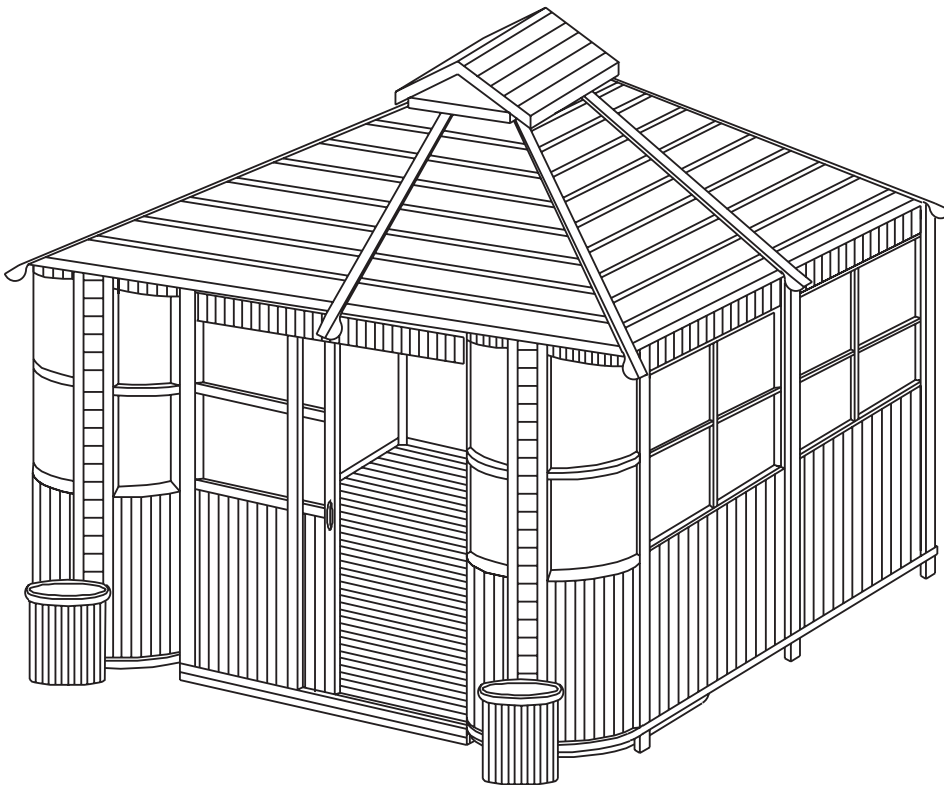

Duplication without written consent is strictly prohibited.

This Owner's Manual is for gazebos manufactured after January 1, 2004

Due to continuous improvement programs, all models, operation, and/or specifications are subject to change without prior notice.

LTR17000776

# Table of Contents

Benefits of Owning a Gazebo .....	2
Safety Instructions .....	3
Contact Information.....	4
Warranty Information .....	4
Set-up and Delivery .....	5
Assembly .....	9
Cleaning, Maintenance and Troubleshooting .....	16
Appendix .....	17
Accessories .....	18
Parts List.....	19
Notes.....	21

### BENEFITS OF OWNING A GAZEBO

Owning a gazebo allows you to have a wonderful place to unwind after a long day of work. It offers a place for you to socialize with family and friends. It offers great cover in the event that you purchase a bar-b-que and/or spa. Owning a gazebo can add character to your patio and/or yard. You can use a gazebo for whatever best suits your needs.

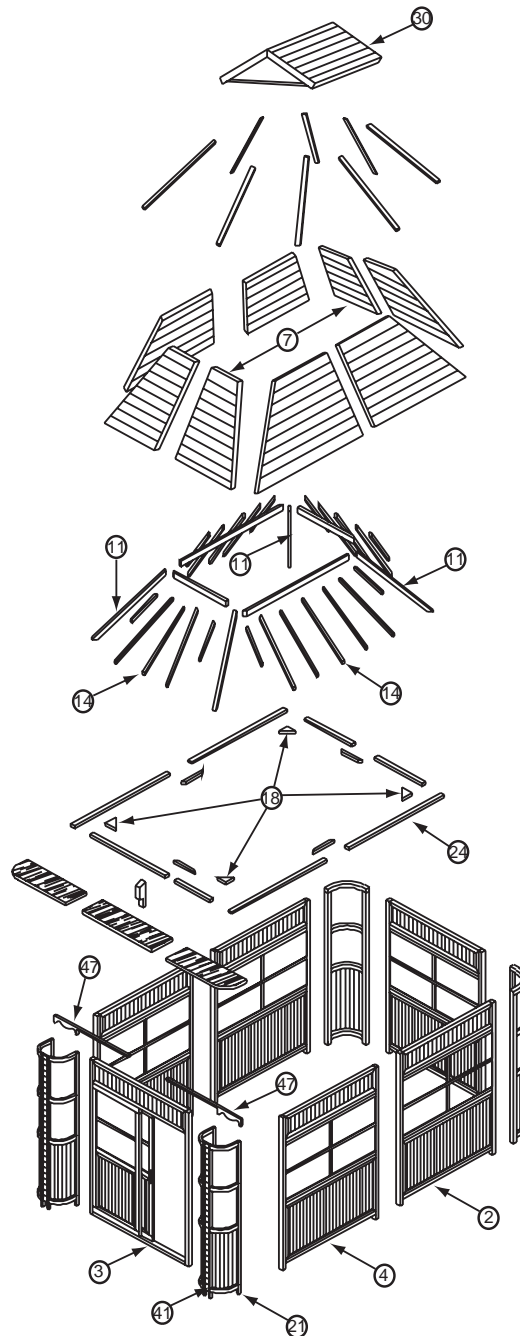

Figure 1. Lighthouse Gazebo

**NOTE:** The numbers in **Figure 1** are located in the back of this manual, in the “Parts List” section.

## **SAFETY INSTRUCTIONS**

### **Carefully read and follow all safety instructions.**

1. When installing and assembling your gazebo, it is recommended that 2 or more people be involved.
2. Do not use the unit during an electrical storm, as there is a remote chance of getting struck by lightning.
3. Do not climb on top of the gazebo. While the gazebo is made out of high-quality wood and is extremely durable, the gazebo is not meant to be used as a jungle gym. Thus, falling off of the gazebo while climbing on it can result in serious injury, possibly even death.
4. Do not attempt any repair without consulting the manufacturer first. Unauthorized repair attempts will void the manufacturer's warranty.

**Save this information.**

## CONTACT INFORMATION

For customer service, please contact your authorized dealer immediately. If you need additional information and/or assistance, please contact:

C.A.I. Customer Service Department  
1462 East Ninth Street  
Pomona, CA 91766  
Toll Free: 1-800-CAL-SPAS  
Fax: 1-909-629-3890

## WARRANTY INFORMATION

See your Cal Spas Creative Wood Designs dealer for a copy of the applicable warranty, details and any questions you may have regarding the warranty coverage on your gazebo.

### Warranty Limitations

The Limited Warranty is void if the gazebo has been subject to negligence, alteration, misuse, abuse, repairs by non- C.A.I. authorized representatives, acts of God and any other cases beyond the control of C.A.I. Examples of common acts invalidating this warranty include but are not limited to:

Use of the gazebo in a non-residential application.

Scratches caused by normal use.

Damage caused by extreme weather conditions. (hot, cold, etc.)

Damage caused by dirt, sand, and/or water damage.

Damage caused by continuous operation of the gazebo with either known or unknown problems.

Damage caused by direct sunlight.

Damage caused as a result of failure to follow the assembly instructions as defined in this Owner's Manual.

This Limited Warranty applies only to gazebos normally used for personal, family, or household purposes.

This Limited Warranty specifically excludes commercial gazebos.

### Warranty Exclusions

C.A.I. warrants the gazebo from defects in material and workmanship for a period of 90 days from the original date of purchase.

**REMINDER: PLEASE DO NOT FORGET TO REGISTER YOUR NEW PRODUCT AT [WWW.CALSPAS.COM](http://WWW.CALSPAS.COM)**

## DELIVERY AND SET-UP

Please make a record of the following. It will be valuable if service is required.

Gazebo Model: \_\_\_\_\_

Gazebo Serial Number: \_\_\_\_\_

Date Purchased: \_\_\_\_\_

Date Installed: \_\_\_\_\_

Gazebo Dealer's Phone Number: \_\_\_\_\_

Gazebo Dealer's Address: \_\_\_\_\_

Most cities and counties require permits for exterior construction and electrical circuits. In addition, some communities have codes requiring residential barriers such as fencing and/or self-closing gates on property to prevent unsupervised access to the property by children under the age of 5. Your dealer can provide information on which permits may be required and how to obtain them prior to the delivery of your equipment.

## PLANNING THE BEST LOCATION FOR YOUR GAZEBO

Here are some of the things that you will need to consider when determining where to locate your new gazebo.

### How Will You Use Your Gazebo?

How you intend to use your gazebo will help you determine where you should position it. For example, will you use your gazebo for recreational purposes? If your gazebo is mainly used for family functions, be sure to leave plenty of room around it for activity. In any case dealing in how it is to be used, you'll probably want to create a specific mood around it.

### Consider Your Privacy

In a cold- weather climate, bare trees won't provide much privacy. Think of your gazebos surroundings during all seasons to determine your best privacy options. Consider the view of your neighbors as well, when you plan the location of your gazebo.

### Provide A View With Your Gazebo

Think about the direction you will be facing when sitting in your gazebo. Do you have a special landscaped area in your yard that you find enjoyable? Perhaps there is an area that catches a soothing breeze during the day and lovely sunset in the evening. Consider these things when you plan your location.

## PREPARING A GOOD FOUNDATION

Your gazebo needs a solid and level foundation. The area that it sits on must be able to support the weight of the gazebo and the occupants who use it. If the foundation is inadequate, it may shift or settle after the gazebo is in place, causing stress that could alter the structures figure and possibly split the wooden joints.

**NOTE:** Damage caused by inadequate or improper foundation support is not covered by the warranty. It is the responsibility of the gazebo owner to provide a proper foundation for the gazebo.

Place the gazebo on an elevated foundation (preferably a 3” concrete slab).

\* If you are installing your gazebo on an elevated wood deck or other structure, it is highly recommended that you consult a structural engineer or contractor to ensure the structure will support the weight.

\* It is strongly recommended that a qualified, licensed contractor prepare the foundation for your gazebo.

## Your Cal Spas Creative Wood Designs Retailer Can Help You With Foundations And More

Your retailer has a wealth of information and experience about how to get the most out of your gazebo. Your gazebo retailer also has a full line of accessories that are engineered to compliment your gazebo.

**NOTE:** It is strongly advised that you have a licensed professional install the foundation for your new gazebo. It is imperative that the foundation is level, as any damage that occurs due to an uneven foundation is not covered by the warranty.

## Size Specifications

<u>Model</u>	<u>Length</u>	<u>Width</u>
Frontier Gazebo	8'	8'
	10'	8'
	12'	8'
Cottage Gazebo	8'	8'
Cabana Gazebo	7'	7'
	7.5'	7.5'
	8'	8'
Northeast Gazebo	7.5'	7.5'
	8'	8'
Lattice Wall Gazebo	7'	7'
	7.5'	7.5'
	8'	8'
	12'	8'
	16'	8'
	10'	10'
	12'	10'
	16'	10'
	12'	12'

<b><u>Model</u></b>	<b><u>Length</u></b>	<b><u>Width</u></b>
Lattice Wall Gazebo (cont.)	12'	12'
	16'	12'
	10' (Octagon)	10'
	12' (Octagon)	12'
Plexi Wall Gazebo	7'	7'
	7.5'	7.5'
	8'	8'
	12'	8'
	16'	8'
	10'	10'
	12'	10'
	12'	12'
	16'	12'
	10' (Octagon)	10'
	12' (Octagon)	12'
	15' (Octagon)	15'
18' (Octagon)	18'	
Luxury Wall Gazebo	7'	7'
	7.5'	7.5'
	8'	8'
	12'	8'
	16'	8'
	10'	10'
	12'	10'
	16'	10'
	12'	12'
	16'	12'
Savannah Wall Gazebo	12'	8'
	10'	10'
	12'	10'
	16'	10'
	12'	12'
	16'	12'
	10' (Octagon)	10'
	12' (Octagon)	12'
Timberline Gazebo	12'	8'
	10'	10'
	12'	10'
	12'	12'
	16'	12'



<b><u>Model</u></b>	<b><u>Length</u></b>	<b><u>Width</u></b>
<b>Lighthouse Gazebo</b>	<b>10'</b>	<b>10'</b>
	<b>12'</b>	<b>10'</b>
	<b>12'</b>	<b>12'</b>
	<b>16'</b>	<b>12'</b>
Plantation Gazebo	10'	10'
	12'	10'
	12'	12'
	16'	12'
Chalet Gazebo	12' (Octagon)	12'
	14' (Octagon)	14'
	16' (Octagon)	16'
Victorian Gazebo	12' (Octagon)	12'
	14' (Octagon)	14'
	16' (Octagon)	16'

**NOTE:** The gazebo above that is listed in bold lettering is the gazebo that you purchased.

**NOTE:** For all gazebos, regardless of model, it is recommended that the foundation (concrete slab, railroad ties or pre-cast stepping stones) extend beyond the dimension of the gazebo. For example, if the gazebo you purchased is 12'x12', you will want your foundation to be 12.5'x12.5'. The reason for this is because it will be easier to maintain the area around the gazebo (mowing the lawn, edging, etc.) without damaging or scarring the gazebo. Also, in doing this, you will eliminate any potential problems, foundation-wise, in the future.

**NOTE:** This Owner's Manual applies to the various sizes that are included in the Lighthouse Gazebo line (10'x10', 12'x10', 12'x12' and 16'x12'). While the sizes will vary from gazebo to gazebo, the assembly instructions will be the same, unless otherwise noted.

## **Tools and Materials**

Utility Knife	25' Tape Measure
Cordless Drill	100' Extension Cord
1/8" Pilot Hole Drill Bit	1/2" Ratchet and Impact Drill
Electric Drill	9/16" Socket
Phillips-Head Drill Tips	1/2" Carbide Drill Bit (Masonry Bit)
Slotted-Head Drill Tips	Sandpaper (Various Grades)
Redwood Stain	Wood Putty
Gray Wash Stain	Rags

# ASSEMBLY INSTRUCTIONS

The following sections will tell you how to assembly your gazebo. If you have any questions, problems with material and/or parts, please contact your local retailer. The electrical service requirements are 110Volts/ 20Amp.

## Wiring Assembly

The Lighthouse Gazebo comes with light fixtures located on the dome and the ceiling light panel (**Figure 2**). These light fixtures are already pre-wired. The owner will have to connect the lights and will also have to supply the power source.

**NOTE:** It is recommended that the owner have the light assembly wired into same panel that the spa is wired to. This should be done by a qualified electrician.

**NOTE:** Please follow the written steps in conjunction with the figures that are shown.

1. The dome light must be wired to the ceiling panel light which, in turn, must be wired to the right front panel.
2. Referring to **Figure 2A** and **Figure 2B**, plug the 4-pin (male) plug into the 4-pin receptacle (female). Make sure the connection is secure.
3. After each connection has been made, carefully tuck any excess wire up and out of the way.

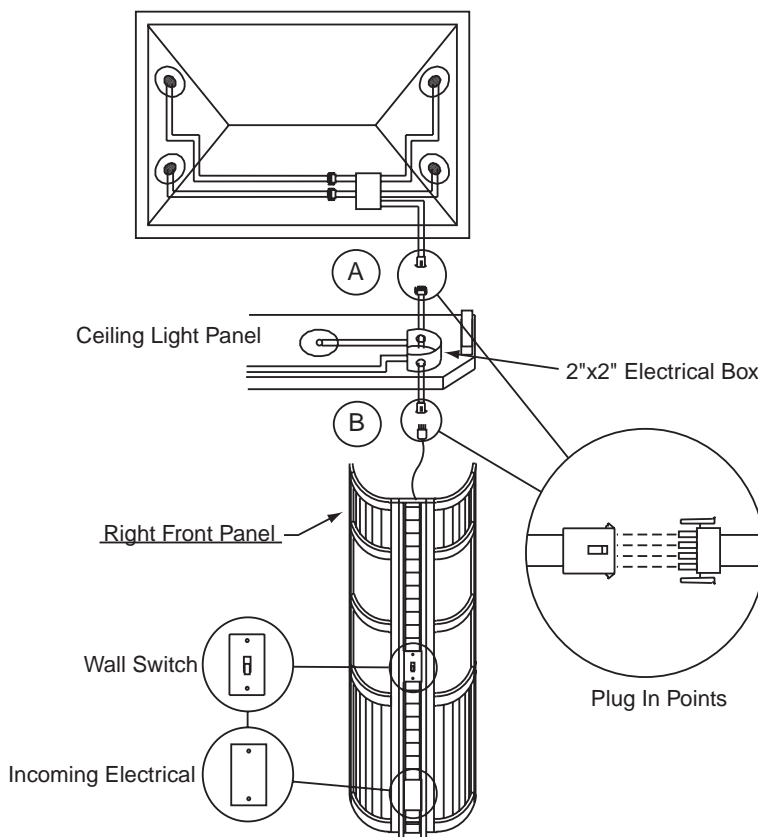

**Figure 2.** Wiring Assembly

### Wall Panel Assembly

**NOTE:** Please follow the written steps in conjunction with the figures that are shown.

1. Stand two panels up side by side. Attach the panels together using 5 drywall screws (**Figure 3A**). Repeat this step until all the panels are attached. **Figure 3B** will show you which order to go in.

**NOTE:** Use care when attaching the corners. Be sure that the windows do not come in contact with the mounting screws.

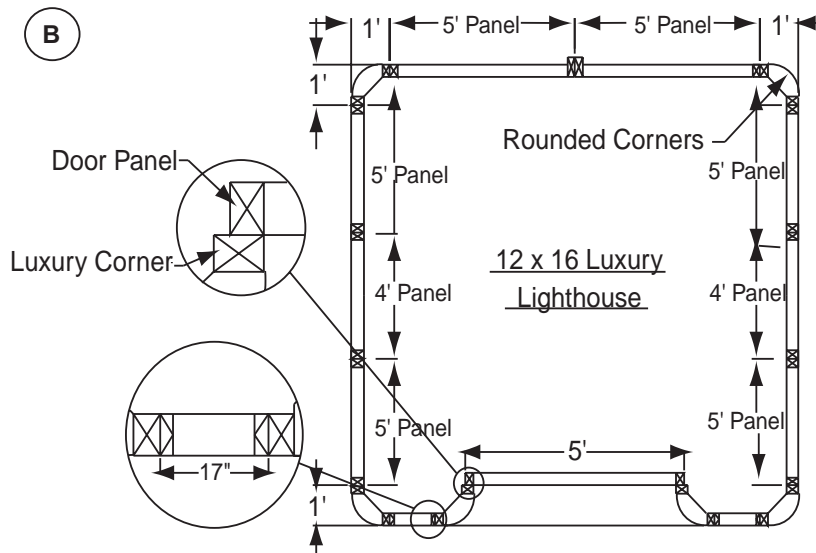
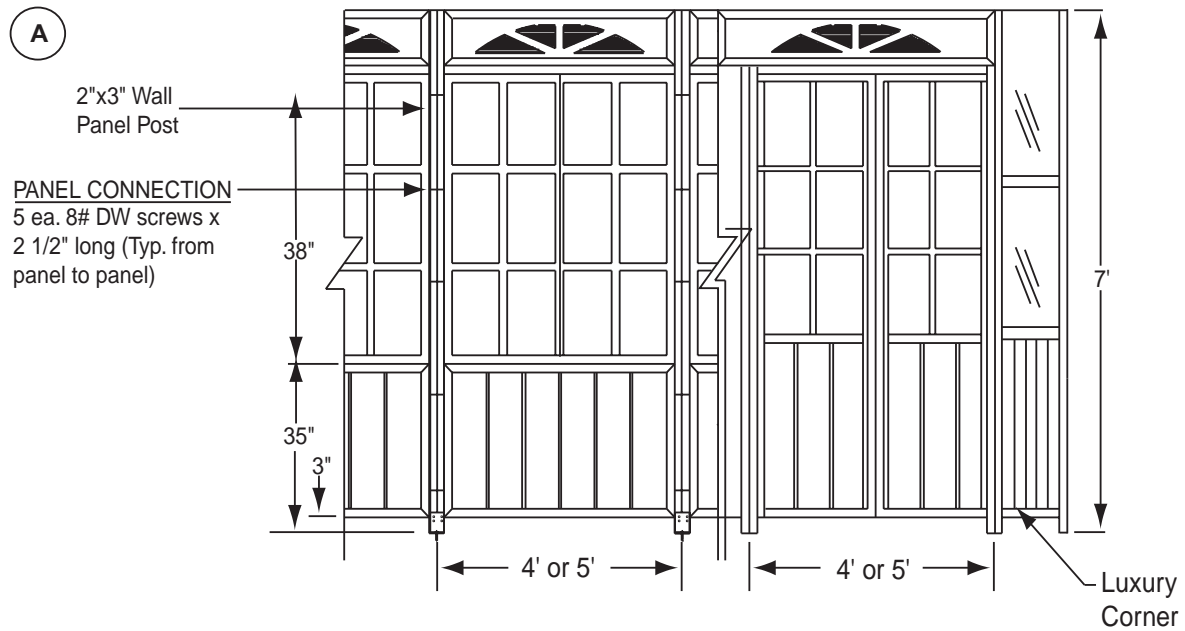
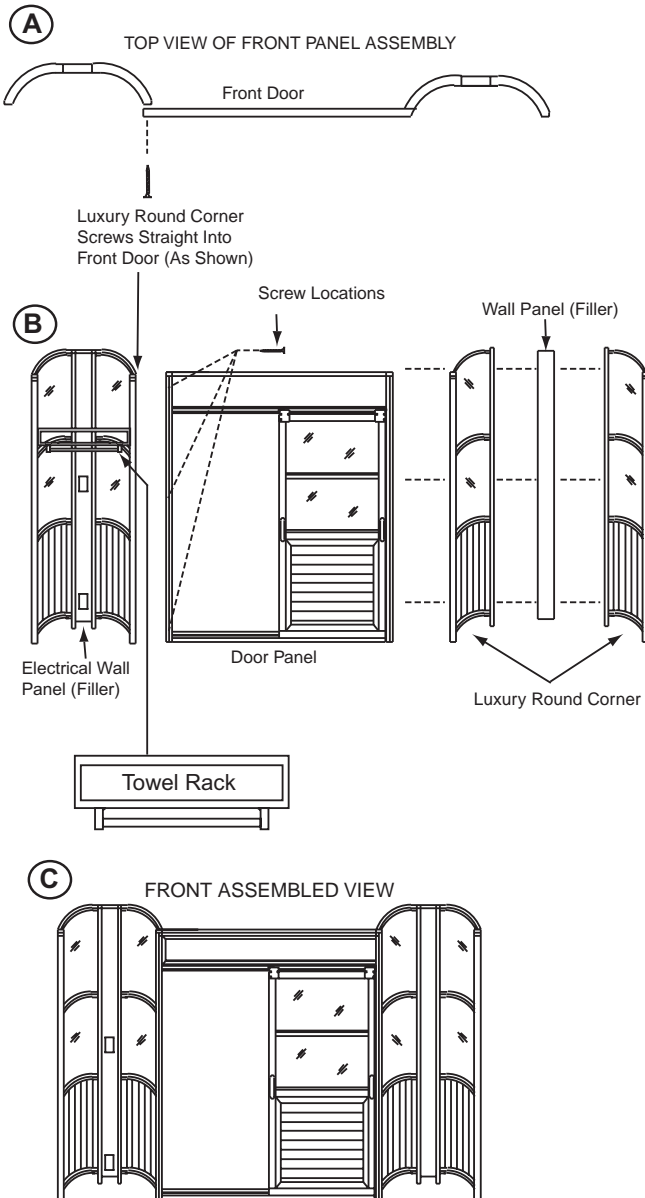

Figure 3. Wall Panel Assembly



**Figure 4.** Front Entrance Panel

## Front Entrance Assembly

**NOTE:** Check the parts list that came with your gazebo and make sure that all the parts are present. Also, please follow the written steps in conjunction with the figures that are shown.

**NOTE:** The following steps will correspond with **Figure 4**. This view is from the inside of the gazebo, not from the outside.

1. Stand two luxury round corners up and attach them to the filler wall panel with 3 drywall screws. Repeat this step for the other side (**Figure 4B**).

**NOTE:** The electrical filler wall panel is distinguished from the other filler wall panel by the cut-outs. These cut-outs will be used for the electrical power input and the light switch.

2. After assembling the corners, stand them up 6' apart. Place the door panel in between the two corner assemblies (**Figure 4B**).
3. Using 3 drywall screws (6 total), attach the corner assemblies to the door panel (**Figure 4B**). Repeat this step for both sides of the door panel.

**NOTE:** Please remember, the view that is shown in **Figure 4** is from the inside of the gazebo. Therefore, the electrical filler panel will be located on the right side.

4. Attach the towel rack to the inside of the left side corner assembly with the provided drywall screws (**Figure 4B**).
5. **Figure 4C** shows how the front entrance assembly will look when completed. Line the corners of the front entrance assembly with the corners of the wall assembly and attach using drywall screws.

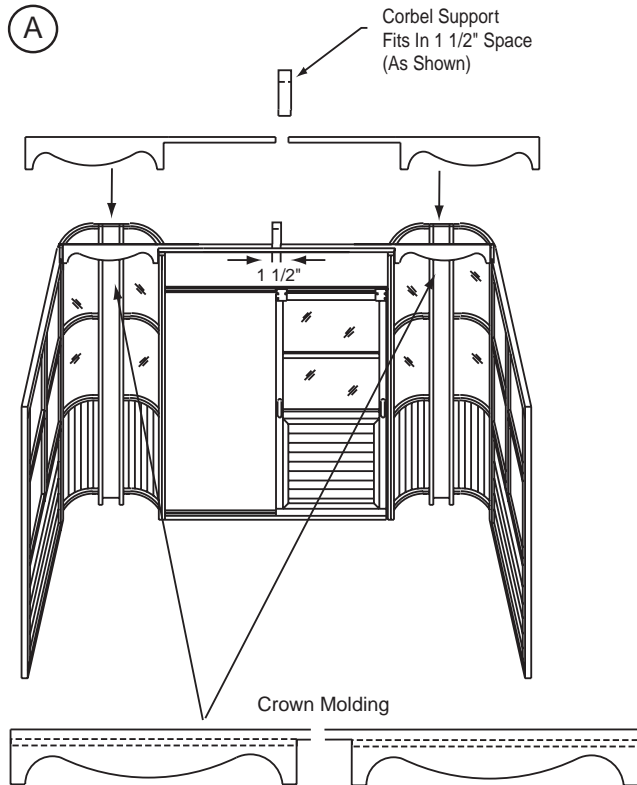

## Overhead Light Panel Assembly

**NOTE:** Check the parts list that came with your gazebo and make sure that all the parts are present. Also, please follow the written steps in conjunction with the figures that are shown.

**NOTE:** The view for **Figure 5A** is from the inside of the gazebo while **Figure 5B** view is from the front of the gazebo.

1. The crown molding must be attached (as shown in **Figure 5A**) using drywall screws. The crown molding will go over each corner assembly.
2. Place the overhead light panel assembly on top of the front wall panel assembly (**Figure 5B**). Align the rounded corners of the light panel with the rounded corners of the wall panel.

**NOTE:** The light locations will be as follows: one light will go in each corner (inside of gazebo); three will be right above the door (outside of gazebo).

4. Attach with drywall screws.
5. Please refer to "Wiring Assembly" on Page 9 for wiring instructions.
6. The 'Electrical-In Box' in **Figure 5B** is where the incoming power will be wired.

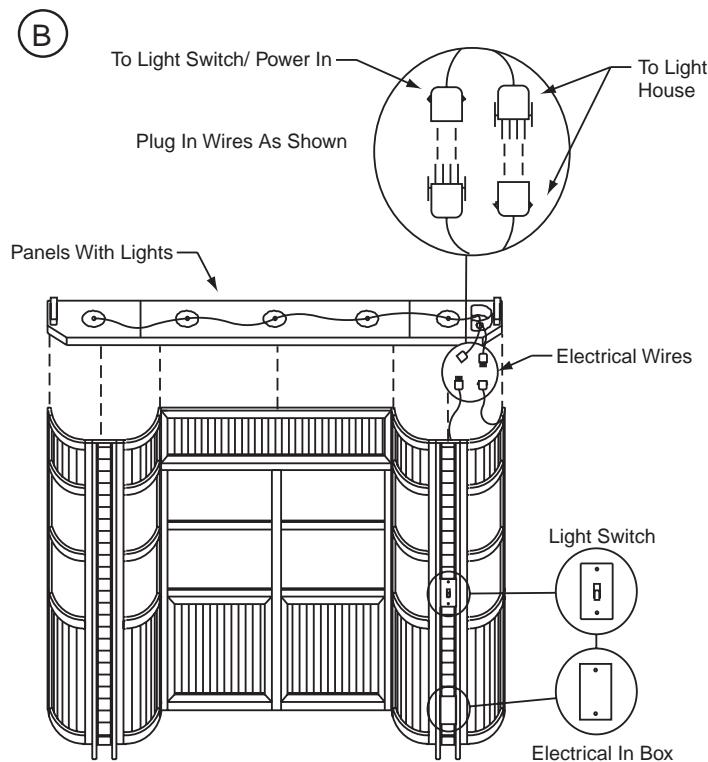

Gazebo is shown without roof for clarity. Roof should be on first then install panels with lights and then plug together.

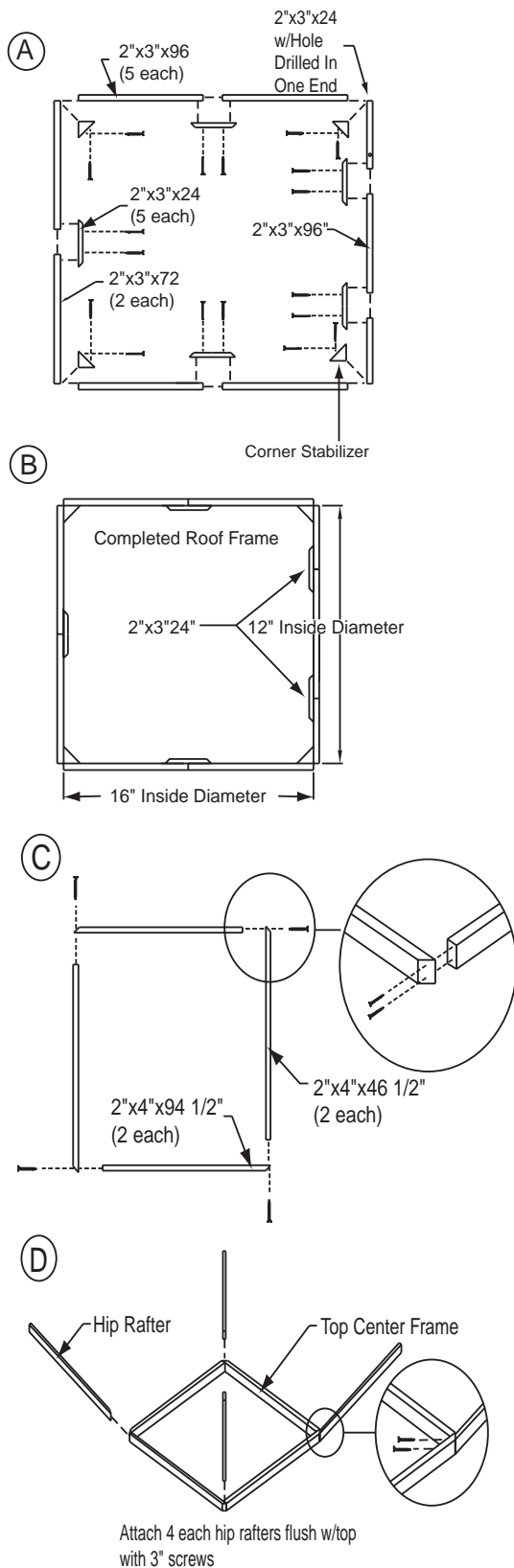

### Roof Frame Assembly

When assembling the roof frame, it is recommended that you place everything out and assemble it on a flat surface. It is also recommended that there be another person available when installing the roof frame on to the gazebo walls.

**NOTE:** Check the parts list that came with your gazebo and make sure that all the parts are present. Also, please follow the written steps in conjunction with the figures that are shown.

1. Lay the roof frame out on a flat surface (**Figure 6A**). Use the provided drywall screws to attach all the pieces together.
2. When complete, the inside dimension should measure 12'x16'. Remove the two 2"x3"x24" pieces after the roof installation is complete (**Figure 6B**).
3. Place corner stabilizer (4 each) and attach in each corner (**Figure 6A**) using drywall screws.
4. Take two 2"x4"x94 1/2" pieces of wood and two 2"x4"x46 1/2" pieces of wood and lay them out on the ground (**Figure 6C**), in effect making a rectangle.
5. Attach each corner together with the provided screws, making sure to keep the 45° corners pointing outward (**Figure 6C - insert**). This is the top center frame.
6. Take the hip rafters (4 each) and attach them to each corner of the top center frame. Make sure that the 45° corner matches the 45° end on the hip rafters (**Figure 6D**).

**Figure 6. Roof Frame Assembly**

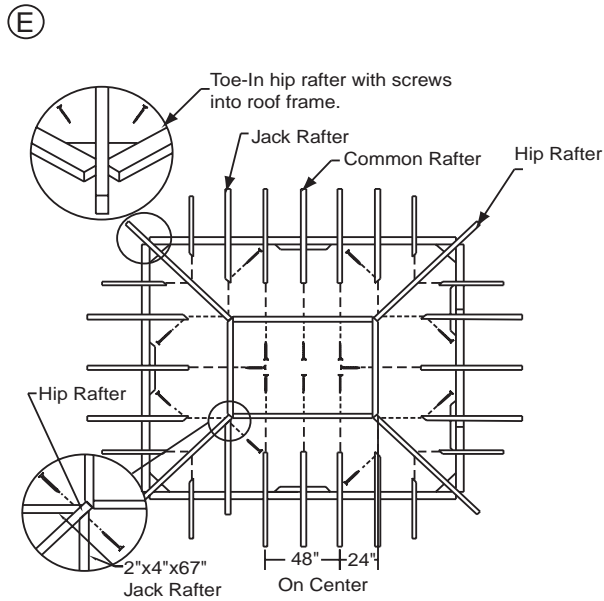

6. After the top center frame has been assembled, place it on top of the roof frame assembly. Toe-in each hip rafter to the roof frame using drywall screws (**Figure 6E**).
7. Take 4 common rafters and attach them to the middle of each side of the top center frame assembly (**Figure 6E**). Use the toe-in method (**see inset**).
8. With the common rafters now installed, attach the remaining jack rafters using the toe-in method. Make sure that each jack rafter is spaced evenly apart. This will ensure sufficient anchoring points for the roof panels.
9. **Figure 6F** shows what the roof frame will look like when it is completed.

**NOTE:** It is recommended that you have an assistant for the following step.

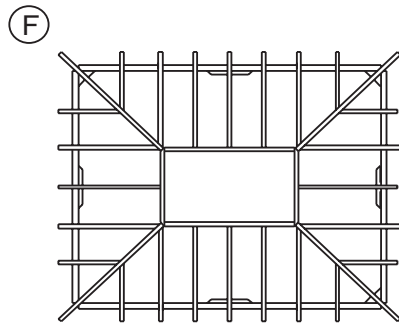

9. Place the assembled roof section on top of the wall panel assembly. Anchor the roof section by using drywall screws (**Figure 6G**).

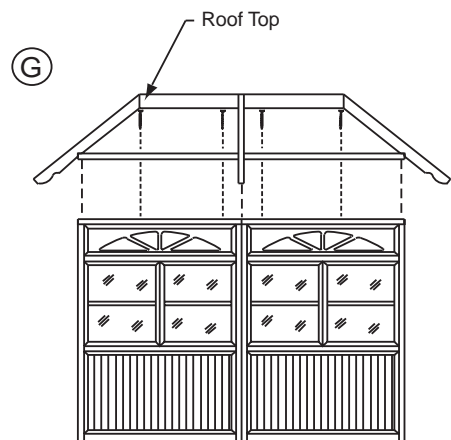

**Figure 6.** Roof Frame Assembly

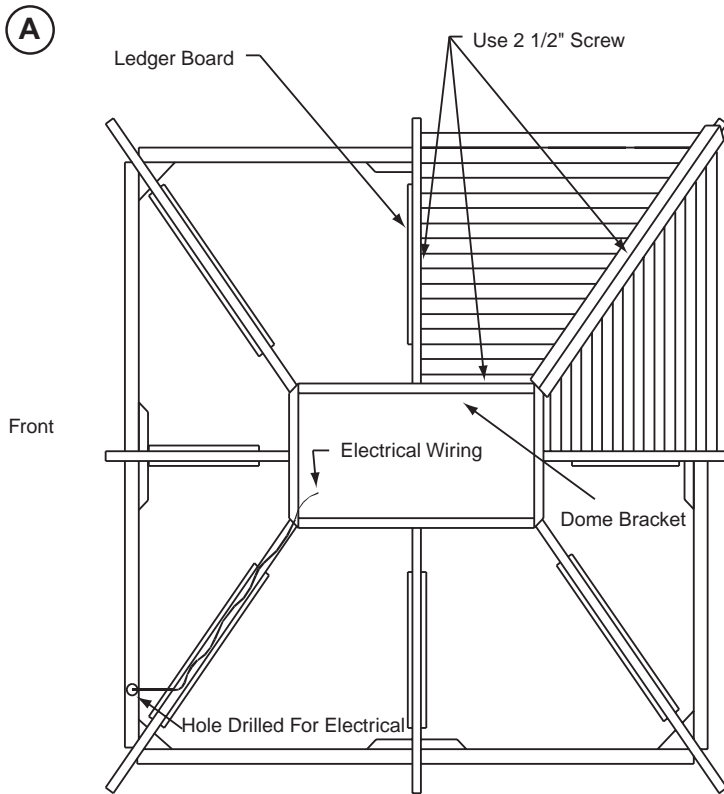

### Roof Panels

**NOTE:** It is strongly recommended that you use a ladder for the final steps of the gazebo assembly.

1. Prior to installing the roof panels, the ledger boards must be installed (**Figure 7A**). Attach each ledger board to the rafters (common, hip and jack) and secure using drywall screws.
2. Place each roof panel in place (pattern facing out) and mount using drywall screws (**Figure 7A**).
3. Using the provided hardware, mount the dome bracket (**Figure 7A**).
4. Use 2 1/2" drywall screws to mount all crown caps (**Figure 7B**).
5. Set the dome light assembly into the dome housing and secure with drywall screws (**Figure 7B**).

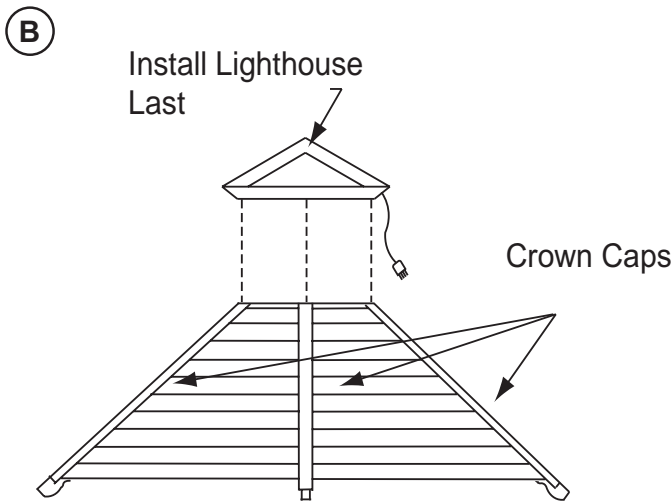



# CLEANING, MAINTENANCE AND TROUBLESHOOTING

## Cleaning

Your gazebo was designed with low cleaning and maintenance in mind. We recommend that the gazebo be cleaned at least twice a month (or more, if needed). When cleaning your gazebo, cleaning solvents are not recommended. Using a sponge and water will be fine. For ground-in dirt and grime, please refer to the following section.

## Maintenance

Maintaining your gazebo will be an easy task. We recommend that every six months you should do an inspection of the wood on your gazebo. Take note of any deformities in the wood (i.e. cracking, peeling, dirt, grime, etc.). It is recommended that you spot sand these areas with 120-grit sandpaper. When complete, wipe these areas clean with a damp rag.

When dry, you must apply a coat of stain to the sanded area. Wipe the stained area clean and reapply until the sanded area matches the rest of the gazebo.

**NOTE:** An 8oz. can of stain will be supplied with each gazebo. To replace the can of stain, please contact your local Cal Enclosures dealer.

**NOTE:** On models that have plexi-glass windows, the use of a cheese cloth and warm water should be used. These windows are made of plexi-glass and do not hold up well under the abrasive conditions that many commercial cleaners generate.

## TROUBLESHOOTING PROCEDURES

**Q: Why will the windows on the gazebo not stay open/closed?**

**A:** This is most likely due to the fact that your foundation is not level. Foundations will most likely have a 1/4" pitch for drainage reasons. To rectify this problem, the gazebo must be shimmed on the low side. Using a standard level, shim the low side so that the gazebo is level.

**Q: Why won't the roof panels not sit correctly on the roof frame?**

**A:** Check the top plate on the top center frame and make sure it is level and installed correctly.

**Q: My roof and wall panels are lining up correctly and there are small gaps in the joint seams. Why is this?**

**A:** The main support post is not "plumb" (meaning vertically level). You must go back and make sure that the main support post is plumb. Also, you must make sure that each of your main support beams is "square" in relation to the main support post (meaning that there is a 90° angle when the main support post and the main support beam intersect).

## APPENDIX

The items that will be covered in this section will consist of the following:

Accessories

Part Numbers

Notes

In order for your retailer to expedite your order, for parts and accessories, it is recommended that you have the information that you attained in the Set-Up and Delivery section. Customer Service will want all this information for warranty purposes.

## ACCESSORIES

The following is a list of all the accessories that you can use with your Cal Spa Creative Wood Designs Gazebo. If you wish to order an accessory, feel free to contact your dealer with the desired part name and part number, or visit [www.calspas.com](http://www.calspas.com).

<u>Description</u>	<u>Size</u>	<u>Wood</u>	<u>Part Number</u>	
			<u>Cal Stone</u>	<u>Deluxe Stone</u>
Bar Top	11'	WOOD289	WOOD289CS	WOOD289DS
	80'	WOOD288	WOOD288CS	WOOD288DS
	75'	WOOD287	WOOD287CS	WOOD287DS
Round Corner		WOOD199	WOOD199CS	WOOD199DS
Storage Bench	11'	WOOD905	WOOD905CS	WOOD905DS
	80'	WOOD902	WOOD902CS	WOOD902DS
	75'	WOOD901	WOOD901CS	WOOD901DS
Crescent S/B		WOOD900	WOOD900CS	WOOD900DS
Bar Corbel		WOO270405060		
Bench Leg		WOO27405020		
Bar Stool		WOOD127	WOOD127CS	WOOD127DS
Surround Step	11'	WOOD296		
	80'	WOOD297		
	75'	WOOD298		
Crescent Step		WOOD214		
30' Step		WOOD107		
30" Storage Step w/Box		WOOD133		
5' Step		WOOD109		
5' Step Storage w/Box		WOOD134		
30" Step w/Handrail		WOOD107-2		
Round Planter		WOOD101		
Square Planter		WOOD100		
Crown Planter		WOOD189		
Octagon Planter		WOOD148		
Crescent Planter		WOOD168		
Bench	11'	WOOD923	WOOD923CS	WOOD923DS
	80'	WOOD922	WOOD922CS	WOOD922DS
	75'	WOOD921	WOOD921CS	WOOD921DS
Crescent Bench		WOOD920	WOOD920CS	WOOD920DS
Privacy Panel		WOOD183		
30" Step (3 tier)	30"	WOOD108		
30" Step (3 Tier with Handrail)	30"	WOOD108-2		
Towel/Wine Glass Rack	4'	WOOD113		
Towel/Wine Glass Rack	5'	WOOD113-5		
Wine Glass Hanger		WOOD114		
Towel Tree		WOOD169		
Kidzone Playhouse		KDZ100		
Corner Towel Bar		WOO27402175		

**PART LIST**

<b>Item Number</b>	<b>Description</b>	<b>Part Number</b>	<b>Quantity</b>
1	48"x95" Deck Assembly	WOO27302700	2
2	5' Luxury Wall Panel, Complete	WOO27102920	6
3	5' Luxury Door, Complete	WOO27107460	1
4	4' Luxury Wall Panel, Complete	WOO27102560	2
5	#7 Metal Roof (R) Top	WOO27200880	4
6	#7 Metal Roof (R), Bottom	WOO27200860	4
7	#7 Metal Roof (L), Top	WOO27200780	4
8	#7 Metal Roof (L) Bottom	WOO27200840	4
9	#9 Metal Roof Top	WOO27200980	2
10	#9 Metal Roof Bottom	WOO27201000	2
11	89' Hip Rafter STD No Slider	WOO27200460	4
12	2"x4"x94.5" M1	WOO27208460	2
13	2"x3"x72" Header Boards Top of Wall	WOO27107700	20
14	2"x4"x67" Common Rafter No Slider	WOO27200480	8
15	2"x4"xB&BTR M1 Moon Roof Frame	WOO27208720	2
16	2"x4"x60" Cross Ties M1	WOO27200140	4
17	2"x3"x96" Header Boards Top Of Wall	WOO27107720	5
18	2"x4"x6 1/2" Corner Stabilizer M2	WOO27200600	4
19	1"x4"x18' M2 Cross Ties	WOO27209180	4
20	2"x4"x45' Center Support	WOO27210580	1
21	Luxury Round Corner	WOO27105940	6
22	Luxury Round Corner (Spa Side)	WOO27105980	1
23	Metal Crown Molding 82 2/3"	HAR13900190	4
24	62' Metal Crown Molding	HAR13900170	6
25	2"x2"x24' M2	WOO27106900	5
26	8"x2"x1/2" Screw Sq. Drive Drywall	HAR13201150	125
27	Screw 8"x3" Sq. Drive Drywall	HAR13201140	25
28	Coil Strap	HAR13900070	4
29	Screw Drywall Square 6"x1 1/4"	HAR13200420	25
30	54"x102" Dome with Frame	WOO27211800	1
31	2"x4"x67' Jack Rafter, No Slider (L)	WOO27200640	4
32	2"x4"x67' Jack Rafter, No Slider (R)	WOO27200620	4
33	2"x4"x43' Jack Rafter (L)	WOO27200660	4
34	2"x4"x43' Jack Rafter (R)	WOO27200580	4
35	Dome Bracket	HAR13800020	6
36	8"x1 1/2 Molding Screw	HAR13200050	50
37	8"x1" Roof Metal Screw	HAR13200200	120
38	2"x3"x24' With Hole For Electric Cable	WOO27508105	1
39	2"x3"x24' Header Board	WOO27750800	1
40	17"x81" Filler Wall Panel	WOO27700114	1
41	17"x81" Electrical Filler Wall Panel	WOO27700116	1
42	14"x41 1/2" Round Deck	WOO27303272	2
43	Storage Bench 41"	WOO27420110	1
44	Storage Bar 41"	WOO27420120	1
45	Wine Glass Holder Towel Rack 41 1/2"	WOO27402190	1

**PART LIST**

<b><u>Item Number</u></b>	<b><u>Description</u></b>	<b><u>Part Number</u></b>	<b><u>Quantity</u></b>
46	Corner Towel Bar	WOO27402175	2
47	2"x6"x42' Facial Inside	WOO27402184	2
48	Lighthouse Patio 12'	WOO27700124	1
49	2"x3"x8 1/2" Front Rafter Support	WOO27402186	1
50	33"x48" Deck	WOO27303274	1
51	48"x48" Deck	WOO27302780	1
52	33"x95" Deck	WOO27303276	1

# NOTES

\$5.00



# 2004 Owner's Manual

## CABANA GAZEBO

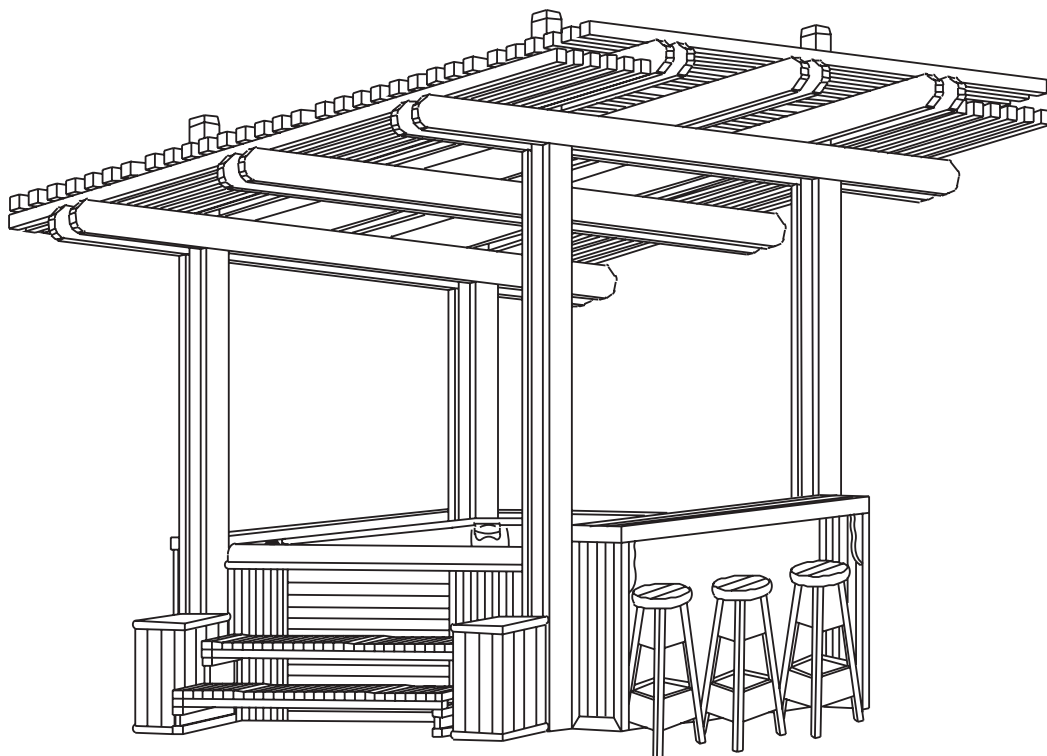

Duplication without written consent is strictly prohibited.

This Owner's Manual is for gazebos manufactured after January 1, 2004

Due to continuous improvement programs, all models, operation, and/or specifications are subject to change without prior notice.

LTR17000771

# Table of Contents

Benefits of Owning a Gazebo .....	2
Safety Instructions .....	3
Contact Information.....	4
Warranty Information .....	4
Set-up and Delivery .....	5
Assembly .....	9
Cleaning, Maintenance and Troubleshooting .....	19
Appendix .....	19
Parts List.....	20
Accessories .....	23
Notes.....	24



## BENEFITS OF OWNING A GAZEBO

Owning a gazebo allows you to have a wonderful place to unwind after a long day of work. It offers a place for you to socialize with family and friends. It offers great cover in the event that you purchase a barbeque and/or spa. Owning a gazebo can add character to your patio and your yard. You can use a gazebo for whatever best suits your needs.

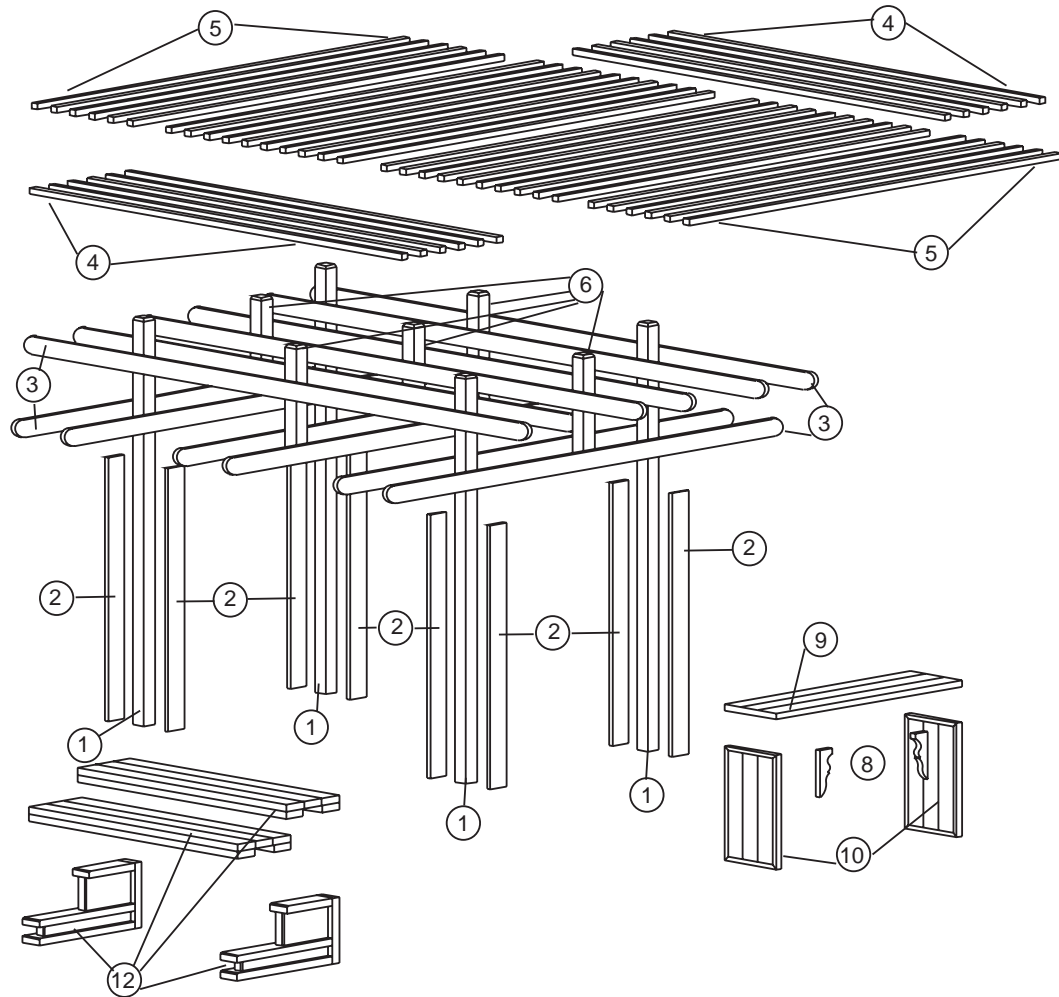

**Figure 1.** Cabana Gazebo (Exploded View)

**NOTE:** Please refer to the parts list located at the end of this manual for a full description on each item number shown above.

## **SAFETY INSTRUCTIONS**

### **Carefully read and follow all safety instructions.**

1. When installing and assembling your gazebo, it is recommended that 2 or more people be involved.
2. Do not use the unit during an electrical storm, as there is a remote chance of getting struck by lightning.
3. Do not climb on top of the gazebo. While the gazebo is made out of high-quality wood and is extremely durable, the gazebo is not meant to be used as a jungle gym. Thus, falling off of the gazebo while climbing on it can result in serious injury, possibly even death.
4. Do not attempt any repair without consulting the manufacturer first. Unauthorized repair attempts will void the manufacturer's warranty (within the first 90 days).

**Save this information.**

## CONTACT INFORMATION

For customer service, please contact your authorized dealer immediately. If you need additional information and/or assistance, please contact:

C.A.I. Customer Service Department  
1462 East Ninth Street  
Pomona, CA 91766  
Toll Free: 1-800-CAL-SPAS  
Fax: 1-909-629-3890

## WARRANTY INFORMATION

See your Cal Enclosures gazebo dealer for a copy of the applicable warranty, details and any questions you may have regarding the warranty coverage on your gazebo.

### Warranty Limitations

The Limited Warranty is void if the gazebo has been subject to negligence, alteration, misuse, abuse, repairs by non- C.A.I. authorized representatives, acts of God and any other cases beyond the control of C.A.I. Examples of common acts invalidating this warranty include but are not limited to:

Use of the gazebo in a non-residential application.

Scratches caused by normal use.

Damage caused by extreme weather conditions. (Hot, cold, etc.)

Damage caused by dirt, sand, and/or water damage.

Damage caused by direct sunlight.

Damage caused as a result of failure to follow the assembly instructions as defined in this Owner's Manual.

This Limited Warranty applies only to gazebos normally used for personal, family, or household purposes.

This Limited Warranty is obsolete 90 days after the original purchase date.

### Warranty Exclusions

C.A.I. warrants the gazebo from defects in material and workmanship for a period of 90 days from the original date of purchase.

**REMINDER: PLEASE DO NOT FORGET TO REGISTER YOUR NEW PRODUCT AT [WWW.CALSPAS.COM](http://WWW.CALSPAS.COM)**

## DELIVERY AND SET-UP

Please make a record of the following. It will be valuable if service is required.

Gazebo Model: \_\_\_\_\_

Gazebo Serial Number: \_\_\_\_\_

Date Purchased: \_\_\_\_\_

Date Installed: \_\_\_\_\_

Gazebo Dealer's Phone Number: \_\_\_\_\_

Gazebo Dealer's Address: \_\_\_\_\_

Most cities and counties require permits for exterior construction and electrical circuits. In addition, some communities have codes requiring residential barriers such as fencing and/or self-closing gates on property to prevent unsupervised access to the property by children under the age of 5. Your dealer can provide information on which permits may be required and how to obtain them prior to the delivery of your equipment.

### Planning the Best Location for Your Gazebo

Here are some of the things that you will need when considering where to locate your new gazebo.

#### How Will You Use Your Gazebo?

How you intend to use your gazebo will help you determine where you should position it. For example, will you use your gazebo for recreational purposes? If your gazebo is mainly used for family functions, be sure to leave plenty of room around it for activity. In any case dealing in how it is to be used, you'll probably want to create a specific mood around it.

#### Consider Your Privacy

In a cold weather climate, bare trees won't provide much privacy. Think of your gazebos surroundings during all seasons to determine your best privacy options. Consider the view of your neighbors as well, when you plan the location of your gazebo.

#### Provide A View With Your Gazebo

Think about the direction you will be facing when sitting in your gazebo. Do you have a special landscaped area in your yard that you find enjoyable? Perhaps there is an area that catches a soothing breeze during the day and lovely sunset in the evening. Consider these things when you plan your location.

## PREPARING A GOOD FOUNDATION

Your gazebo needs a solid and level foundation. The area that it sits on must be able to support the weight of the gazebo and the occupants who use it. If the foundation is inadequate, it may shift or settle after the gazebo is in place, causing stress that could **DAMAGE YOUR GAZEBO**.

**NOTE:** Damage caused by inadequate or improper foundation support is not covered by the warranty. It is the responsibility of the gazebo owner to provide a proper foundation for the spa.

Place the gazebo on an elevated foundation (**preferably a 3" concrete slab**). Be sure that the concrete slab is at least 12" wider than the outside dimension on the gazebo. (See **NOTE:** on page 8.)

- \* If you are installing your spa on an elevated wood deck or other structure, it is highly recommended that you consult a structural engineer or contractor to ensure the structure will support the weight of 150 Lbs./ sq. ft.
- \* It is strongly recommended that a qualified, licensed contractor prepare the foundation for your spa.

## Your Cal Enclosures Retailer Can Help You With Foundations And More

Your retailer has a wealth of information and experience about how to get the most out of your gazebo. Your gazebo retailer also has a full line of accessories that are engineered to compliment your gazebo.

**NOTE:** It is strongly advised that you have a licensed professional install the foundation for your new gazebo. It is imperative that the foundation is level, as any damage that occurs due to an uneven foundation is not covered by the warranty.

## Size Specifications

<b><u>Model</u></b>	<b><u>Length</u></b>	<b><u>Width</u></b>
Frontier Gazebo	8'	8'
	10'	8'
	12'	8'
Cottage Gazebo	8'	8'
<b>Cabana Gazebo</b>	<b>7'</b>	<b>7'</b>
	<b>7.5'</b>	<b>7.5'</b>
	<b>8'</b>	<b>8'</b>
Northeast Gazebo	7.5'	7.5'
	8'	8'
Lattice Wall Gazebo	7'	7'
	7.5'	7.5'
	8'	8'
	12'	8'
	16'	8'
	10'	10'
	12'	10'
	16'	10'
12'	12'	

<b><u>Model</u></b>	<b><u>Length</u></b>	<b><u>Width</u></b>
Lattice Wall Gazebo (cont.)	12'	12'
	16'	12'
	10' (Octagon)	10'
	12' (Octagon)	12'
Plexi Wall Gazebo	7'	7'
	7.5'	7.5'
	8'	8'
	12'	8'
	16'	8'
	10'	10'
	12'	10'
	12'	12'
	16'	12'
	10' (Octagon)	10'
	12' (Octagon)	12'
	15' (Octagon)	15'
18' (Octagon)	18'	
Luxury Wall Gazebo	7'	7'
	7.5'	7.5'
	8'	8'
	12'	8'
	16'	8'
	10'	10'
	12'	10'
	16'	10'
	12'	12'
	16'	12'
Savannah Wall Gazebo	12'	8'
	10'	10'
	12'	10'
	16'	10'
	12'	12'
	16'	12'
	10' (Octagon)	10'
	12' (Octagon)	12'
15' (Octagon)	15'	
18' (Octagon)	18'	
Timberline Gazebo	12'	8'
	10'	10'
	12'	10'
	12'	12'
	16'	12'

<b><u>Model</u></b>	<b><u>Length</u></b>	<b><u>Width</u></b>
Lighthouse Gazebo	10'	10'
	12'	10'
	12'	12'
	16'	12'
Plantation Gazebo	10'	10'
	12'	10'
	12'	12'
	16'	12'
Chalet Gazebo	12'(Octagon)	12'
	14'(Octagon)	14'
	16'(Octagon)	16'
Victorian Gazebo	12'(Octagon)	12'
	14' (Octagon)	14'
	16' (Octagon)	16'

**NOTE:** The gazebo above that is listed in bold lettering is the gazebo that you purchased.

**NOTE:** For all gazebos, regardless of model, it is recommended that the foundation extend beyond the dimension of the gazebo. For example, if the gazebo you purchased is 12'x12', you will want your foundation to be 14'x14'. The reason for this is because it will be easier to maintain the area around the gazebo (mowing the lawn, edging, etc.) without damaging or scarring the gazebo. Also, in doing this, you will eliminate any potential problems, foundation-wise, in the future.

**NOTE:** This Owner's Manual applies to the various sizes that are included in the Cabana Gazebo line (7'x7', 7.5"x7.5", and 8"x8"). While the sizes will vary from gazebo to gazebo, the assembly instructions will be the same, unless otherwise noted.

## **Tools and Materials**

Utility Knife	25' Tape Measure
Cordless Drill	100' Extension Cord
1/8" Pilot Hole Drill Bit	1/2" Ratchet and Impact Drill
Electric Drill	9/16" Socket
Phillips-Head Drill Tips	1/2" Carbide Drill Bit (Masonry Bit)
Slotted-Head Drill Tips	Sandpaper (Various Grades)
Redwood Stain	Wood Putty
Gray Wash Stain	Rags

## ASSEMBLY INSTRUCTIONS

The following will tell you how to assembly your gazebo. If you have any questions, problems with material and/or parts, please contact your local retailer.

**NOTE:** It is strongly advised that you have a licensed professional install the foundation for your new gazebo. It is imperative that the foundation is level, as any damage that occurs due to an uneven foundation is not covered by the warranty.

**NOTE:** When assembling the gazebo, the owner must determine one thing: What is the gazebo going to cover? If the answer is patio furniture, then the owner can place the gazebo where ever they want it. If the answer is a spa, then it is recommended that the spa be located in the center of the slab (for weight distribution) with the gazebo main supports mounted to the concrete at each of the four corners.

1. Prior to the delivery of your new Cal Spa, it is recommended that you determine where your spa will be placed. (For example: if you are going to center your spa on the concrete slab, take measurements that will enable you to determine where the edges of the spa will be located. When done, mark the corner locations.)
2. Upon delivery of your new Cal Spa, notify the installation crew that you have determined where you want the spa located.
3. After the spa has been installed and is operating, the assembly of the your new gazebo may begin.

**IMPORTANT NOTE:** THIS GAZEBO IS A FREE-STANDING UNIT. AS WITH ANY STRUCTURE, IT IS CRITICAL THAT ALL THE MAIN SUPPORT POSTS BE VERTICALLY LEVEL, OR PLUMB. IF THE FIRST MAIN SUPPORT POST IS NOT VERTICALLY LEVEL, OR PLUMB, THEN THE ENTIRE GAZEBO WILL NOT BE VERTICALLY LEVEL. THE BEST WAY TO KEEP THE STRUCTURE LEVEL IS TO USE A LEVEL AFTER EACH TIME AN ITEM IS ATTACHED OR TIGHTENED. THIS WILL ENSURE THAT AFTER EACH MAJOR STEP IS TAKEN, THE GAZEBO IS STILL LEVEL.



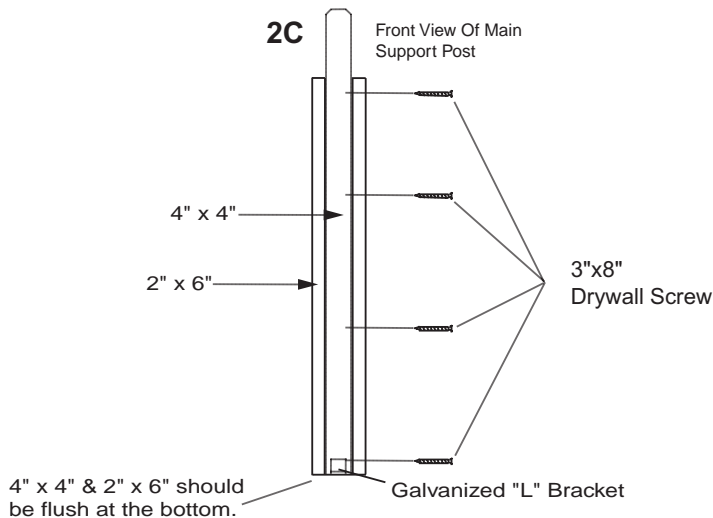
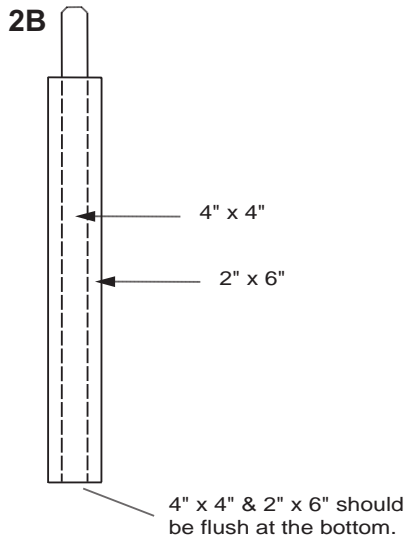
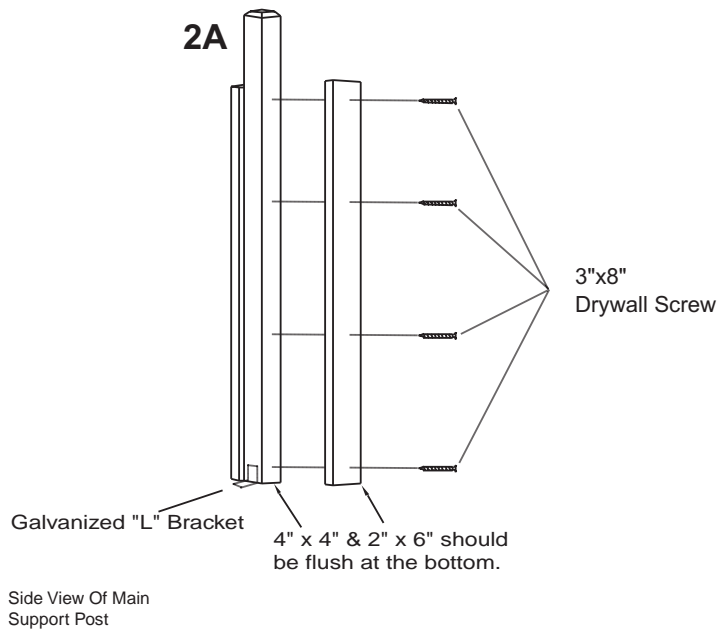

1. Using the materials that are provided in your gazebo kit, take one 4"x4"x108' (9') piece of lumber and 2 2"x6"x90" (7 1/2') pieces of lumber (**Figure 2A**).
2. Take the 2"x6" and center the lumber on the 4"x4" piece of lumber. Once this is done, take four drywall screws (3"x8") and attach the 2"x6" to the 4"x4" (**Figure 2B and 2C**). Repeat this sequence for the other 2"x6".

**NOTE:** The 4"x4" and the 2"x6" (both pieces) should be flush at the bottom.

3. Once this is complete, repeat these steps for all four sides of the gazebo.
4. Using the provided hardware, attach the galvanized "L" bracket to the 4"x4" (either side) as shown in **Figure 2C**.
5. With the use of a level, and after ensuring that the 2"x6" is between the spa and the 4"x4", check that the support is level (top to bottom), and mark the location of the anchoring hole by scoring the concrete.

**Figure 2. Cabana Support Assembly**

Determine spacing of post with spa size before anchoring into concrete.

### Anchoring the Main Support Post

**NOTE:** When scoring the concrete, make sure that the mark is dark enough to see, as you will be drilling a hole in the concrete. This hole will be where the anchoring bolt is located. Also, it is the owner's responsibility to obtain a 1/2" masonry bit. This bit will be used to drill the anchoring holes in the foundation. A masonry bit may be bought at any local hardware store.

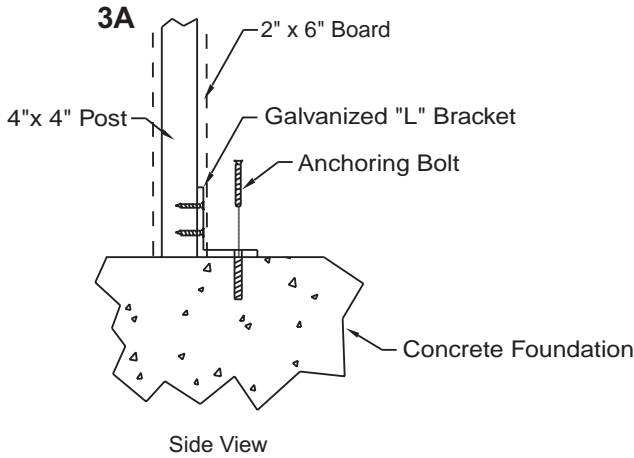

Anchor post into concrete as shown.

1. Pre-drill the anchoring hole using a 1/2" masonry drill bit (see **NOTE** above). Drill the hole to a depth of no less than 3". Using a hammer, insert the anchoring bolt by gently tapping the bolt into place. Continue to tap into place until the anchoring bolt is seated securely in the hole.
2. After drilling the hole and inserting the anchoring bolt, slide the main support post assembly on to the anchoring bolt and tighten down using the provided hardware.
3. Repeat these steps for all four corners of the gazebo.

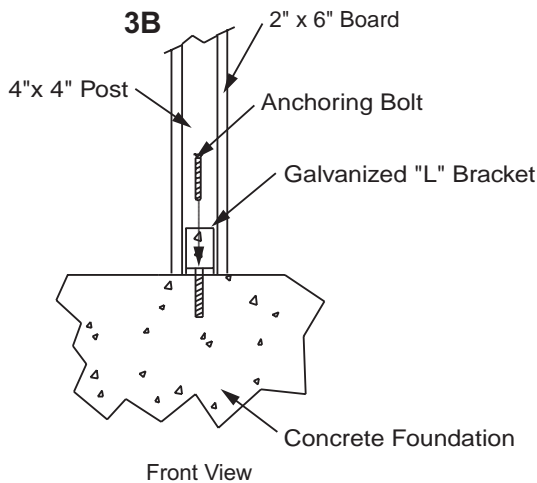

**Figure 3.** Anchoring Main Support Post

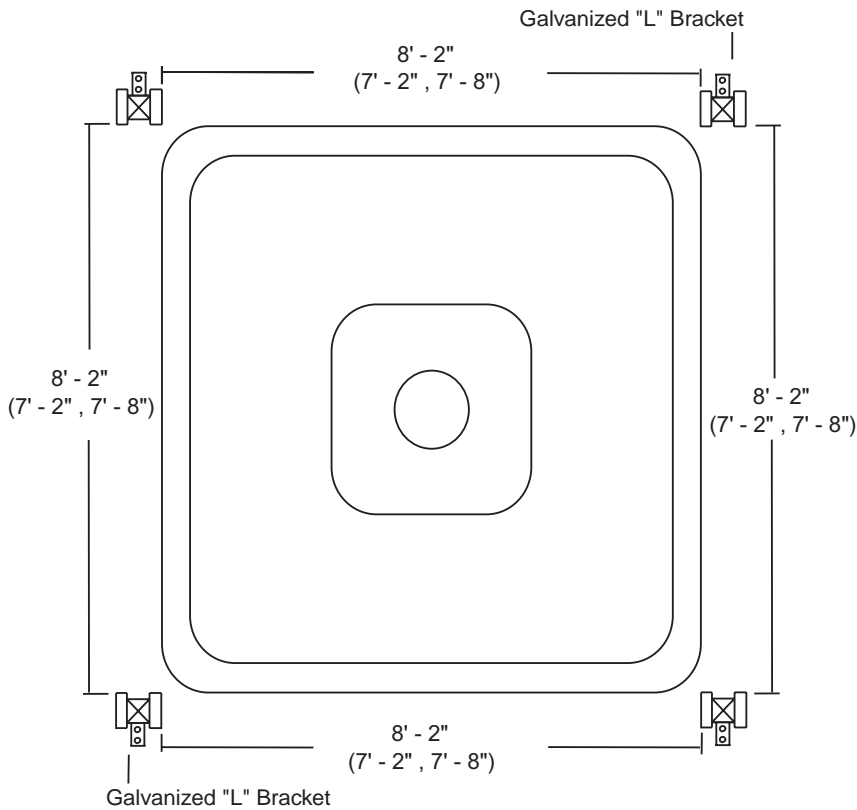

**Figure 4. Main Support Post Location**

The final placement of the main support posts is noted to the left (**Figure 4**). The main support posts should be mounted no less than 1” from the side of the spa. If the gazebo is touching the spa, and any damage is incurred due to contact, the warranty on the spa siding is void.

The total distance between each main support post will be determined by the size of the spa and gazebo that was purchased. The Cabana Gazebo has 3 sizes: 7’x7’, 7.5’x7.5’, and 8’x8’. The desired distance between each main support post will be determined by the aforementioned sizes.

The list below will tell you what each distance should be for each gazebo model :

**If the spa is.....**

7’ x 7’

7.5’ x 7.5’

8’ x 8’

**Then the distance between each gazebo main support post is....**

+/- 7’ - 2” x 7’ - 2”

+/- 7’ - 8” x 7’ - 8”

+/- 8’ - 2” x 8’ - 2”

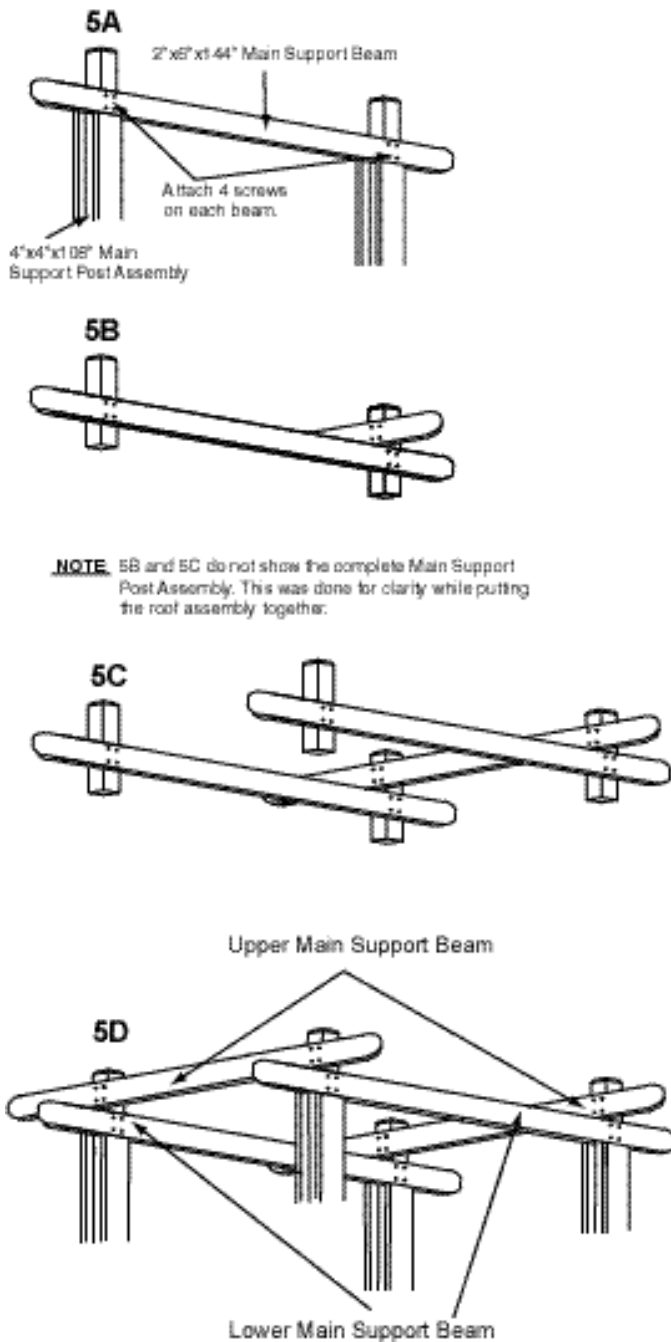

Figure 5. Roof Support Assembly

## Roof Assembly

The roof assembly is a relatively easy process. The majority of the tasks are repetitive. The first part of the roof that needs to be assembled are the support members. It is recommended that the lower support members be installed first and the upper support members second. The support members are the 2"x6"x144" (12').

### Support Member Assembly

**NOTE:** REQUIRE THE HELP OF ANOTHER PERSON. IT IS ADVISED THAT THERE BE TWO LADDERS AVAILABLE WHEN HANGING THE MAIN SUPPORT BEAMS.

**TIP:** TRY ANCHORING THE LADDERS SO THEY DO NOT MOVE WHILE YOU ARE ON TOP OF THEM.

1. With the aid of a ladder, place one 2"x6"x144" roof support on top of the 2"x6"x90" piece (see **Figure 2**) and anchor it to the 4"x4", using the provided drywall screws. Make sure that the 2"x6"x144" is centered between the two 4"x4" main support posts.
2. Place another 2"x6"x144" roof support on the opposite side of the 4"x4" main support post. Screw this piece to the 4"x4" as well.
3. Repeat this process on the other main support posts that are directly across from the main support posts that were just completed.
4. Referring to **Figure 5A**, place another 2"x6"x144" roof support on top of the roof support that was just installed. This next roof support will in effect create a 90° angle with the other 2"x6"x144" roof support. Secure the roof support with the provided drywall screws.
5. Repeat these steps for the remaining roof support beams.

A. Sectional view of 16" x 4" x 4" post. Post can be flush with bottom or be the same height as the four outer posts, as shown.

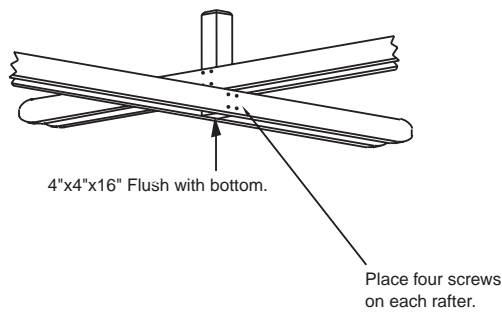

The 4"x4"x16" post is used to tie the roof grid together and re-enforce it (**Figure 6**). These posts should be mounted flush with the bottom of the roof support beams (**Figure 6**) so they are at the same height as the main support posts.

**Figure 6. Roof Re-Enforcement**

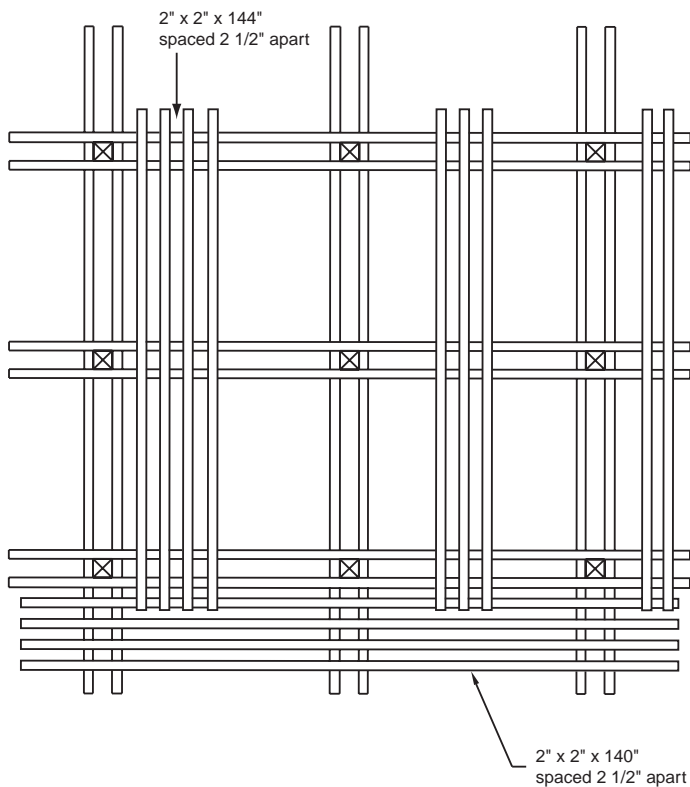

**Final Roof Assembly**

1. Lay out the 2"x2"x140" roof slats on the two lower levels of the gazebo. Make sure that each roof slat is spaced exactly 2 1/2" apart. Twelve roof slats total will be used on the lower level (**Figures 7 and 8**).
2. Secure each roof slat securely in place with 2 1/2" drywall screws.
3. Lay out the 2"x2"x144" roof slats on the one upper level of the gazebo. Make sure that each roof slat is spaced exactly 2 1/2" apart. Twelve roof slats total will be used on the lower level (**Figures 7 and 8**). These roof slats need to be running the opposite direction as the lower level roof slats.

**Figure 7. Roof Configuration**

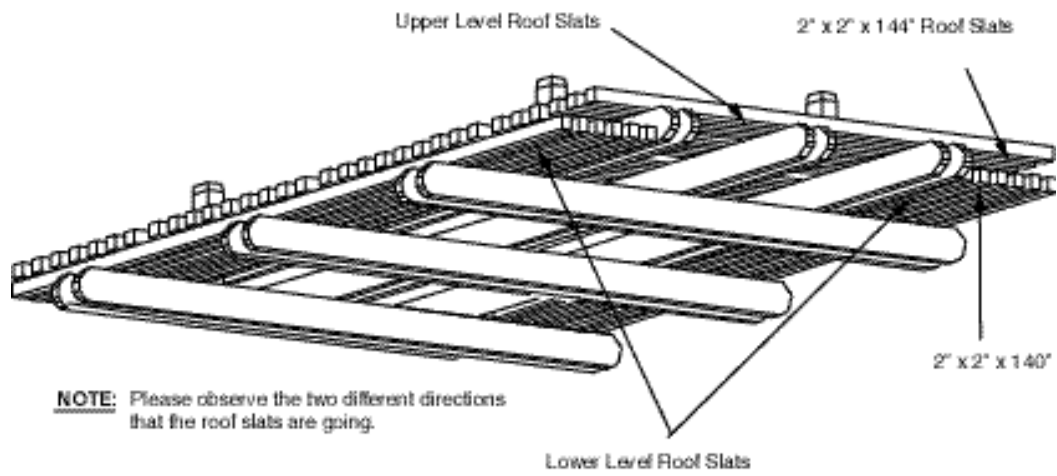

**Figure 8. Roof Configuration**

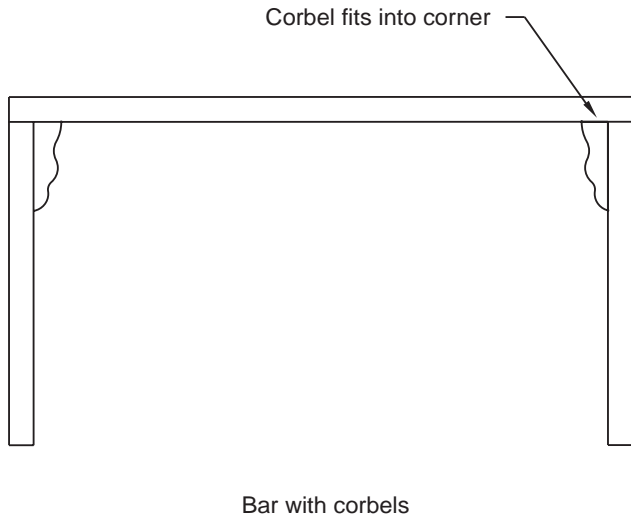

**Bar and Corbel Installation**

1. Place the bar top face down on the ground (**Figure 9**).

**NOTE:** Use care when placing the bar top on the ground. It is recommended that a sheet, or a blanket, be placed on the ground with the bar top being placed on top of the material.

2. Place the bar legs with the decorative finish facing outward. Fasten to the bar top with 2 1/2" screws.
3. Fasten bar corbel to bar top and bar legs with 2 1/2" screws.

**NOTE:** Once the bar assembly is complete, place the bar between the main support posts. Push the bar assembly all the way against the spa. Attach the bar to the main support posts by using drywall screws.

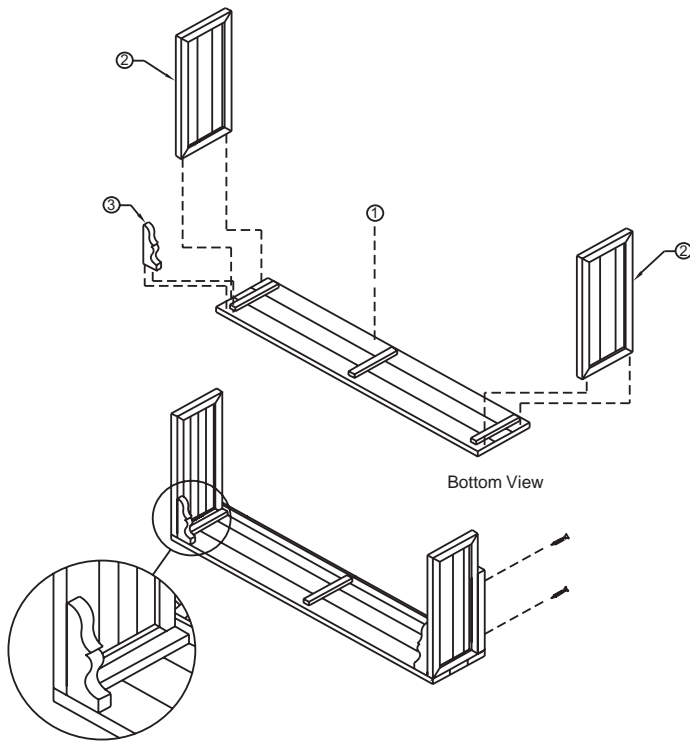

**INSTRUCTIONS**

1. Place bar top face down.
2. Place bar legs w/detail facing outwards and fasten to bar top with 2 1/2" screws.
3. Fasten bar corbel to bar top and bar legs with 2 1/2" screws.

**Figure 9. Corbel and Bar Installation**

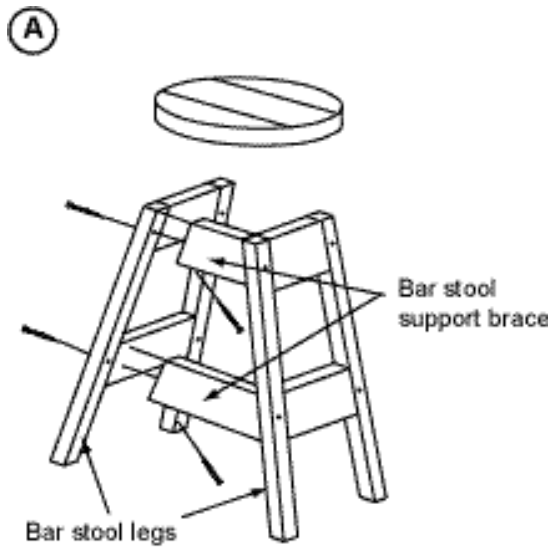

1. Attach sides to legs.

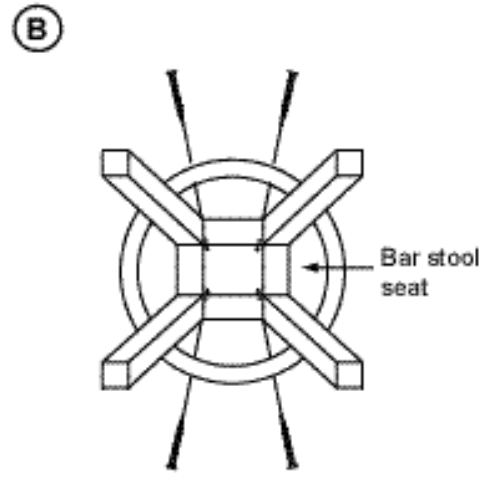

**BOTTOM VIEW**

2. Attach seat to leg assembly.



### Bar Stool Assembly

The final step in the assembly of your Cabana Gazebo is the assembly of your bar stool(s).

1. Attach the bar stool legs to the support brace using the provided drywall screws. There will be a total of 12 screws (**Figure 10A**).
2. Place the bar stool seat on a flat surface (make sure that the finish side is on the ground). Attach the leg assembly using 4 drywall screws (**Figure 10B**).

**Figure 10.** Bar Stool Assembly



## Step Assembly

The Cabana Gazebo comes with a 2-level 5' step assembly. These steps will not need to be mounted to the spa or the gazebo.

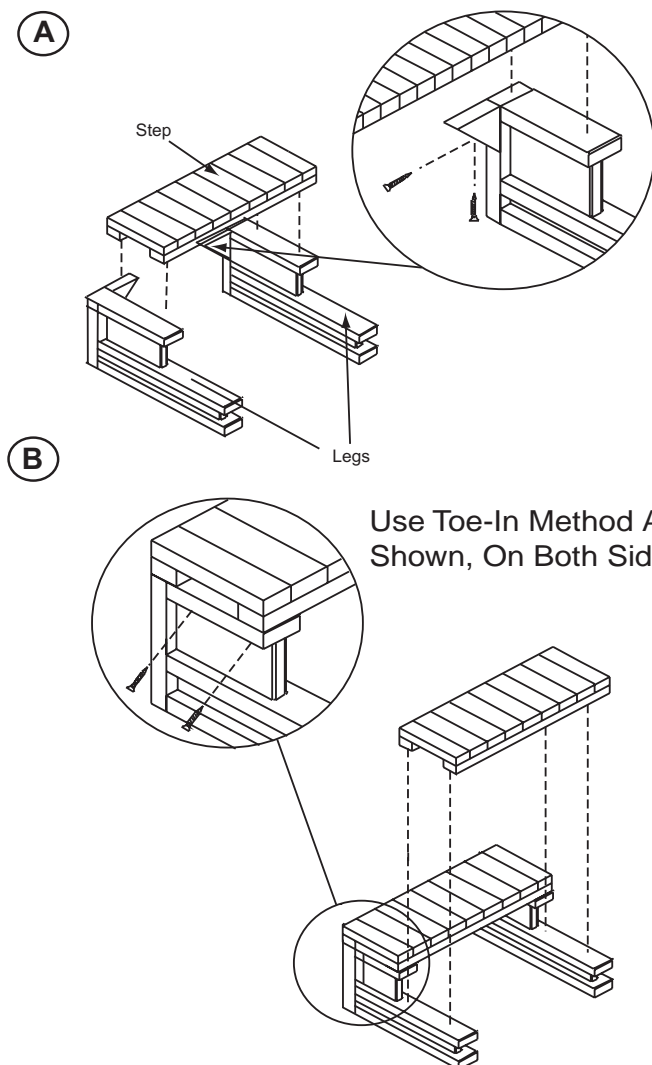

1. Stand the legs up at 5' apart. Place the upper step on top of the upper section of the step (**Figure 11A**).
2. To attach the step, screw in 4 screws (2 at each rear corner): 1 into the step leg and 1 into the step itself (see insert of **Figure 11A**).
3. Place the lower step on the lower section of the step (**Figure 11B**).
4. To attach the step, screw in 4 screws (2 on each on the outside of the step - see insert on **Figure 11B**). Use the toe-in method on both sides, as shown.

**Figure 11.** Gazebo Step Assembly

# CLEANING, MAINTENANCE and TROUBLESHOOTING

## Cleaning

Your gazebo was designed with low cleaning and maintenance in mind. We recommend that the gazebo be cleaned at least twice a month (or more, if needed). When cleaning your gazebo, cleaning solvents are not recommended. Using a sponge and water will be fine. For ground-in dirt and grime, please refer to the following section.

## Maintenance

Maintaining your gazebo will be an easy task. We recommend that every six months you should do an inspection of the wood on your gazebo. Take note of any deformities in the wood (i.e. cracking, peeling, dirt, grime, etc.). It is recommended that you spot sand these areas with 120-grit sandpaper. When complete, wipe these areas clean with a damp rag.

When dry, you must apply a coat of stain to the sanded area. Wipe the stained area clean and reapply until the sanded area matches the rest of the gazebo.

**NOTE:** An 8oz. can of stain will be supplied with each gazebo. To replace the can of stain, please contact your local Cal Enclosures dealer.

**NOTE:** On models that have plexi-glass windows, the use of a cheese cloth and warm water should be used. These windows are made of plexi-glass and do not hold up well under the abrasive conditions that many commercial cleaners generate.

## TROUBLESHOOTING PROCEDURES

**Q: Why won't the roof panels not sit correctly on the roof frame?**

**A:** Check the top plate on the top center frame and make sure it is level and installed correctly.

**Q: My roof and wall panels are not lining up correctly and there are small gaps in the joint seams. Why is this?**

**A:** The main support post is not "plumb" (meaning vertically level). You must go back and make sure that the main support post is plumb. Also, you must make sure that each of your main support beams is "square" in relation to the main support post (meaning that there is a 90° angle when the main support post and the main support beam intersect).

## PARTS LIST

### 7'x7' CABANA GAZEBO

<u>Item Number</u>	<u>Description</u>	<u>New Part Number</u>	<u>Quantity</u>
1	4'x4'x108" CLR & BTR	WOO27106760	4
2	2'x6'x90" B & BTR	WOO27402960	8
3	2'x6'x144" B & BTR	WOO27106720	12
4	2'x2'x140" B & BTR	WOO27106780	14
5	2'x2'x108" B & BTR	WOO27106800	35
6	4'x4'x16.5" CLR & BTR	WOO27106820	5
7	71" Chaise Lounge Base 12-700	WOO27402720	2
8	2'x3'x10.5" Bar Corbels (w/notch)	WOO27403060	6
9	79" Bar Top (12-700)	WOO27402420	1
10	16"x33" Bar Legs	WOO27402900	8
11	Bar Stools N/S	WOO27403300	4
12	19.5"x22" Steps, Cabana	WOO27401980	2
13	Chaise Lounge Back Rest	WOO27402480	2
14	5' Steps	WOO27401680	1
15	Square Planters	WOO27400560	2
16	8"x3" Screw SQ Drive Drywall	HAR13201140	20
17	8"x2.5" Screw SQ Drive Drywall	HAR13201150	100
18	4'x4'x12" Step, Cabana 19.5"x88" Legs	WOO27402100	8
19	10.5" Corbels (w/out notch)	WOO27210940	4
20	1/2"x2 3/4" Anchoring Bolt	HAR13900050	4
21	Gazebo Galvanized "L" Bracket	WOO27903780	4

**7.5'x7.5' CABANA GAZEBO**

<u>Item Number</u>	<u>Description</u>	<u>New Part Number</u>	<u>Quantity</u>
1	4'x4'x108" CLR & BTR	WOO27106760	4
2	2'x6'x90" B & BTR	WOO27402960	8
3	2'x6'x144" B & BTR	WOO27106720	12
4	2'x2'x140" B & BTR	WOO27106780	12
5	2'x2'x108" B & BTR	WOO27106800	35
6	4'x4'x16.5" CLR &BTR	WOO27106820	5
7	85" Chaise Lounge Base12-750	WOO27402780	1
8	2'x3'x10.5" Bar Corbel (w/notch)	WOO27403060	6
9	77" Bar Top (12-750)	WOO27402820	2
10	16"x33" Bar Legs	WOO27402900	8
11	Bar Stools N/S	WOO27403300	4
12	19.5"x22" Steps Cabana	WOO27401980	2
13	Chaise Lounge Back Rest	WOO27402480	2
14	5' Steps	WOO27401680	1
15	Square Planters	WOO27400560	2
16	8"x3" Screw SQ Drive Drywall	HAR13201140	20
17	8"x2.5" Screw SQ Drive Drywall	HAR13201150	100
18	4'x4'x12' Step Cabana 19.5"x88" Legs	WOO27402100	8
19	10.5" Corbels (w/out notch)	WOO27210940	4
20	1/2"x2 3/4" Anchoring Bolt	HAR13900050	4
21	Gazebo Galvanized "L" Bracket	WOO27903780	4

**8'x8' CABANA GAZEBO**

<b><u>Item Number</u></b>	<b><u>Description</u></b>	<b><u>New Part Number</u></b>	<b><u>Quantity</u></b>
1	4'x4'x108" CLR & BTR	WOO27106760	4
2	2'x6'x90" B & BTR	WOO27402960	8
3	2'x6'x144" B & BTR	WOO27106720	12
4	2'x2'x140" B & BTR	WOO27106780	10
5	2'x2'x108" B & BTR	WOO27106800	35
6	4'x4'x16.5" CLR &BTR	WOO27106820	5
7	85" Chaise Lounge Base12-750	WOO27402780	1
8	2'x3'x10.5" Bar Corbels (w/notch)	WOO27403060	6
9	8' Bar Top Assembly	WOO27402820	1
10	16"x33" Bar Legs	WOO27402900	8
11	Bar Stools N/S	WOO27403300	4
12	19.5"x22" Steps Cabana	WOO27401980	2
13	Chaise Lounge Back Rest	WOO27402480	2
14	5' Steps	WOO27401680	1
15	Square Planters	WOO27400560	2
16	8"x3" Screw SQ Drive Drywall	HAR13201140	20
17	8"x2.5" Screw SQ Drive Drywall	HAR13201150	100
18	1/2"x2 3/4" Anchoring Bolt	HAR13900050	4
19	Gazebo Galvanized "L" Bracket	WOO27903780	4
20	4'x4'x12' Step Cabana 19.5"x88" Legs	WOO27402100	8
21	10.5" Corbels (w/out notch)	WOO27210940	4

## ACCESSORIES

The following is a list of all the accessories that you can use with your Cal Spa Creative Wood Designs Gazebo. If you wish to order an accessory, feel free to contact your dealer with the desired part name and part number, or visit [www.calspas.com](http://www.calspas.com).

<b>Description</b>	<b>Size</b>	<b>Wood</b>	<b>Part Number</b>	
			<b>Cal Stone</b>	<b>Deluxe Stone</b>
Bar Top	11'	WOOD289	WOOD289CS	WOOD289DS
	80'	WOOD288	WOOD288CS	WOOD288DS
	75'	WOOD287	WOOD287CS	WOOD287DS
Round Corner		WOOD199	WOOD199CS	WOOD199DS
Storage Bench	11'	WOOD905	WOOD905CS	WOOD905DS
	80'	WOOD902	WOOD902CS	WOOD902DS
	75'	WOOD901	WOOD901CS	WOOD901DS
Crescent S/B		WOOD900	WOOD900CS	WOOD900DS
Bar Corbel		WOO270405060		
Bench Leg		WOO27405020		
Bar Stool		WOOD127	WOOD127CS	WOOD127DS
Surround Step	11'	WOOD296		
	80'	WOOD297		
	75'	WOOD298		
Crescent Step		WOOD214		
30' Step		WOOD107		
30" Storage Step w/Box		WOOD133		
5' Step		WOOD109		
5' Step Storage w/Box		WOOD134		
30" Step w/Handrail		WOOD107-2		
Round Planter		WOOD101		
Square Planter		WOOD100		
Crown Planter		WOOD189		
Octagon Planter		WOOD148		
Crescent Planter		WOOD168		
Bench	11'	WOOD923	WOOD923CS	WOOD923DS
	80'	WOOD922	WOOD922CS	WOOD922DS
	75'	WOOD921	WOOD921CS	WOOD921DS
Crescent Bench		WOOD920	WOOD920CS	WOOD920DS
Privacy Panel		WOOD183		
30" Step (3 tier)	30"	WOOD108		
30" Step (3 Tier with Handrail)	30"	WOOD108-2		
Towel/Wine Glass Rack	4'	WOOD113		
Towel/Wine Glass Rack	5'	WOOD113-5		
Wine Glass Hanger		WOOD114		
Towel Tree		WOOD169		
Kidzone Playhouse		KDZ100		

# NOTES

\$5.00



# 2004 Owner's Manual

## PLANTATION GAZEBO

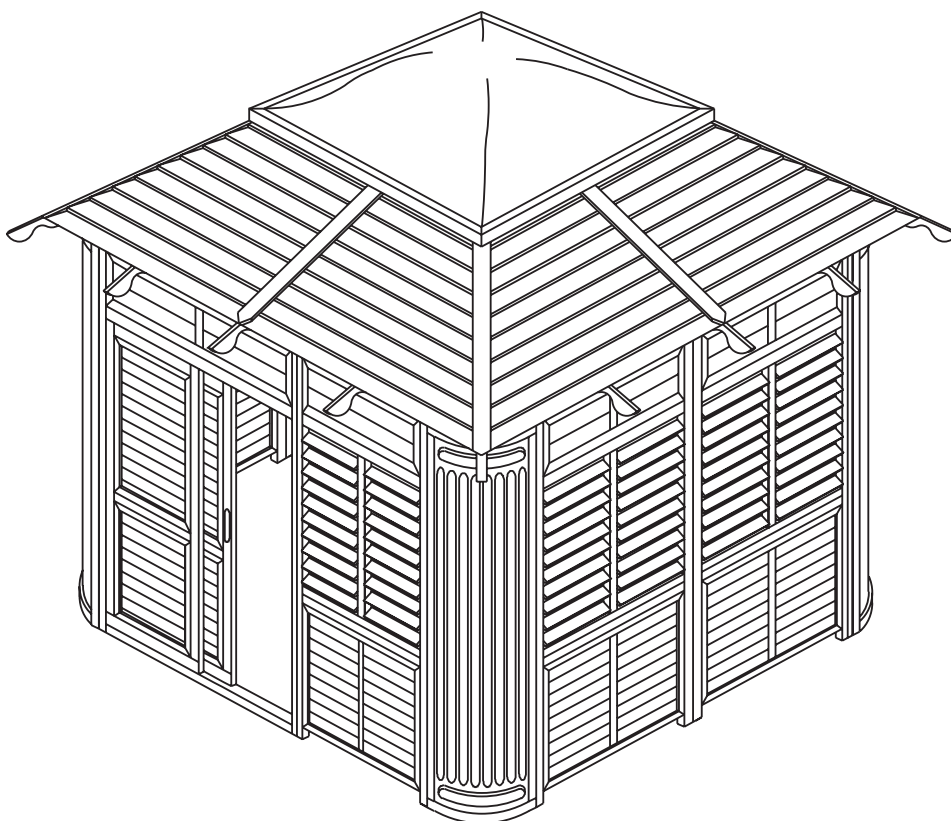

Duplication without written consent is strictly prohibited.

This Owner's Manual is for gazebos manufactured after January 1, 2004

Due to continuous improvement programs, all models, operation, and/or specifications are subject to change without prior notice.

LTR17000779



# Table of Contents

Benefits of Owning a Gazebo .....	2
Safety Instructions .....	3
Contact Information.....	4
Warranty Information .....	4
Set-up and Delivery .....	5
Assembly .....	9
Cleaning, Maintenance and Troubleshooting .....	13
Appendix .....	14
Accessories .....	15
Parts List.....	16
Notes.....	17

### BENEFITS OF OWNING A GAZEBO

Owning a gazebo allows you to have a wonderful place to unwind after a long day of work. It offers a place for you to socialize with family and friends. It offers great cover in the event that you purchase a bar-b-que and/or spa. Owning a gazebo can add character to your patio and/or yard. You can use a gazebo for whatever best suits your needs.

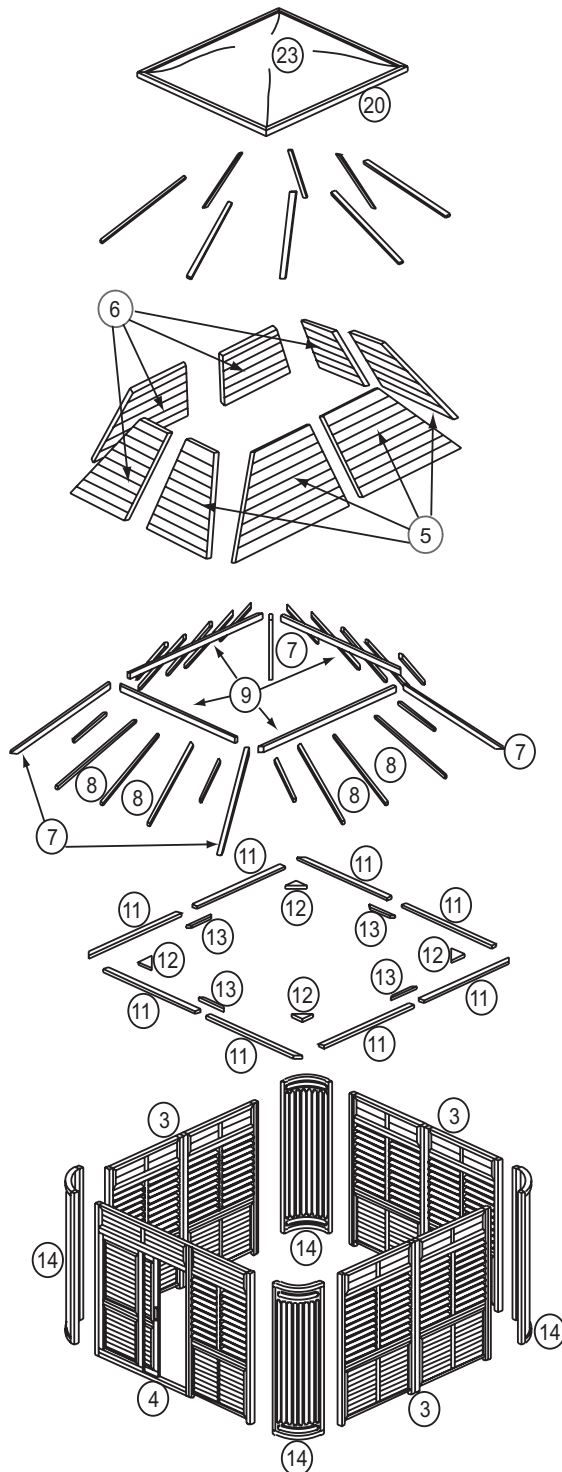

Figure 1. Plantation Gazebo

**NOTE:** Each item number listed above can be found in the “Parts List” section of this manual.

## **SAFETY INSTRUCTIONS**

### **Carefully read and follow all safety instructions.**

1. When installing and assembling your gazebo, it is recommended that 2 or more people be involved.
2. Do not use the unit during an electrical storm. as there is a remote chance of getting struck by lightening.
3. Do not climb on top of the gazebo. While the gazebo is made out of high-quality wood and is extremely durable, the gazebo is not meant to be used as a jungle gym. Thus, falling off of the gazebo while climbing on it can result in serious injury, possibly even death.
4. Do not attempt any repair without consulting the manufacturer first. Unauthorized repair attempts will void the manufacturer's warranty.

**Save this information.**

## CONTACT INFORMATION

For customer service, please contact your authorized dealer immediately. If you need additional information and/or assistance, please contact:

C.A.I. Customer Service Department  
1462 East Ninth Street  
Pomona, CA 91766  
Toll Free: 1-800-CAL-SPAS  
Fax: 1-909-629-3890

## WARRANTY INFORMATION

See your Cal Spas Creative Wood Designs dealer for a copy of the applicable warranty, details and any questions you may have regarding the warranty coverage on your gazebo.

### Warranty Limitations

The Limited Warranty is void if the gazebo has been subject to negligence, alteration, misuse, abuse, repairs by non- C.A.I. authorized representatives, acts of God and any other cases beyond the control of C.A.I. Examples of common acts invalidating this warranty include but are not limited to:

Use of the gazebo in a non-residential application.

Scratches caused by normal use.

Damage caused by extreme weather conditions. (hot, cold, etc.)

Damage caused by dirt, sand, and/or water damage.

Damage caused by continuous operation of the gazebo with either known or unknown problems.

Damage caused by direct sunlight.

Damage caused as a result of failure to follow the assembly instructions as defined in this Owner's Manual.

This Limited Warranty applies only to gazebos normally used for personal, family, or household purposes.

This Limited Warranty specifically excludes commercial gazebos.

### Warranty Exclusions

C.A.I. warrants the gazebo from defects in material and workmanship for a period of 90 days from the original date of purchase.

**REMINDER: PLEASE DO NOT FORGET TO REGISTER YOUR NEW PRODUCT AT [WWW.CALSPAS.COM](http://WWW.CALSPAS.COM)**

## DELIVERY AND SET-UP

Please make a record of the following. It will be valuable if service is required.

Gazebo Model: \_\_\_\_\_

Gazebo Serial Number: \_\_\_\_\_

Date Purchased: \_\_\_\_\_

Date Installed: \_\_\_\_\_

Gazebo Dealer's Phone Number: \_\_\_\_\_

Gazebo Dealer's Address: \_\_\_\_\_

Most cities and counties require permits for exterior construction and electrical circuits. In addition, some communities have codes requiring residential barriers such as fencing and/or self-closing gates on property to prevent unsupervised access to the property by children under the age of 5. Your dealer can provide information on which permits may be required and how to obtain them prior to the delivery of your equipment.

## PLANNING THE BEST LOCATION FOR YOUR GAZEBO

Here are some of the things that you will need to consider when determining where to locate your new gazebo.

### How Will You Use Your Gazebo?

How you intend to use your gazebo will help you determine where you should position it. For example, will you use your gazebo for recreational purposes? If your gazebo is mainly used for family functions, be sure to leave plenty of room around it for activity. In any case dealing in how it is to be used, you'll probably want to create a specific mood around it.

### Consider Your Privacy

In a cold- weather climate, bare trees won't provide much privacy. Think of your gazebo's surroundings during all seasons to determine your best privacy options. Consider the view of your neighbors as well, when you plan the location of your gazebo.

### Provide A View With Your Gazebo

Think about the direction you will be facing when sitting in your gazebo. Do you have a special landscaped area in your yard that you find enjoyable? Perhaps there is an area that catches a soothing breeze during the day and lovely sunset in the evening. Consider these things when you plan your location.

## PREPARING A GOOD FOUNDATION

Your gazebo needs a solid and level foundation. The area that it sits on must be able to support the weight of the gazebo and the occupants who use it. If the foundation is inadequate, it may shift or settle after the gazebo is in place, causing stress that could alter the structures figure and possibly split the wooden joints.

**NOTE:** Damage caused by inadequate or improper foundation support is not covered by the warranty. It is the responsibility of the gazebo owner to provide a proper foundation for the gazebo.

Place the gazebo on an elevated foundation (preferably a 3” concrete slab).

\* If you are installing your gazebo on an elevated wood deck or other structure, it is highly recommended that you consult a structural engineer or contractor to ensure the structure will support the weight.

\* It is strongly recommended that a qualified, licensed contractor prepare the foundation for your gazebo.

## Your Cal Spas Creative Wood Designs Retailer Can Help You With Foundations And More

Your retailer has a wealth of information and experience about how to get the most out of your gazebo. Your gazebo retailer also has a full line of accessories that are engineered to compliment your gazebo.

**NOTE:** It is strongly advised that you have a licensed professional install the foundation for your new gazebo. It is imperative that the foundation is level, as any damage that occurs due to an uneven foundation is not covered by the warranty.

## Size Specifications

<u>Model</u>	<u>Length</u>	<u>Width</u>
Frontier Gazebo	8'	8'
	10'	8'
	12'	8'
Cottage Gazebo	8'	8'
Cabana Gazebo	7'	7'
	7.5'	7.5'
	8'	8'
Northeast Gazebo	7.5'	7.5'
	8'	8'
Lattice Wall Gazebo	7'	7'
	7.5'	7.5'
	8'	8'
	12'	8'
	16'	8'
	10'	10'
	12'	10'
	16'	10'
	12'	12'

<b><u>Model</u></b>	<b><u>Length</u></b>	<b><u>Width</u></b>
Lattice Wall Gazebo (cont.)	12'	12'
	16'	12'
	10' (Octagon)	10'
	12' (Octagon)	12'
Plexi Wall Gazebo	7'	7'
	7.5'	7.5'
	8'	8'
	12'	8'
	16'	8'
	10'	10'
	12'	10'
	12'	12'
	16'	12'
	10' (Octagon)	10'
	12' (Octagon)	12'
	15' (Octagon)	15'
18' (Octagon)	18'	
Luxury Wall Gazebo	7'	7'
	7.5'	7.5'
	8'	8'
	12'	8'
	16'	8'
	10'	10'
	12'	10'
	16'	10'
	12'	12'
	16'	12'
Savannah Wall Gazebo	12'	8'
	10'	10'
	12'	10'
	16'	10'
	12'	12'
	16'	12'
	10' (Octagon)	10'
	12' (Octagon)	12'
15' (Octagon)	15'	
18' (Octagon)	18'	
Timberline Gazebo	12'	8'
	10'	10'
	12'	10'
	12'	12'
	16'	12'

<b><u>Model</u></b>	<b><u>Length</u></b>	<b><u>Width</u></b>
Lighthouse Gazebo	10'	10'
	12'	10'
	12'	12'
	16'	12'
<b>Plantation Gazebo</b>	<b>10'</b>	<b>10'</b>
	<b>12'</b>	<b>10'</b>
	<b>12'</b>	<b>12'</b>
	<b>16'</b>	<b>12'</b>
Chalet Gazebo	12'(Octagon)	12'
	14'(Octagon)	14'
	16'(Octagon)	16'
Victorian Gazebo	12'(Octagon)	12'
	14' (Octagon)	14'
	16' (Octagon)	16'

**NOTE:** The gazebo above that is listed in bold lettering is the gazebo that you purchased.

**NOTE:** For all gazebos, regardless of model, it is recommended that the foundation (concrete slab, railroad ties or pre-cast stepping stones) extend beyond the dimension of the gazebo. For example, if the gazebo you purchased is 12'x12', you will want your foundation to be 12.5'x12.5'. The reason for this is because it will be easier to maintain the area around the gazebo (mowing the lawn, edging, etc.) without damaging or scarring the gazebo. Also, in doing this, you will eliminate any potential problems, foundation-wise, in the future.

**NOTE:** This Owner's Manual applies to the various sizes that are included in the Plantation Gazebo line (10'x10', 12'x10', 12'x12' and 16'x12'). While the sizes will vary from gazebo to gazebo, the assembly instructions will be the same, unless otherwise noted.

## **Tools and Materials**

Utility Knife	25' Tape Measure
Cordless Drill	100' Extension Cord
1/8" Pilot Hole Drill Bit	1/2" Ratchet and Impact Drill
Electric Drill	9/16" Socket
Phillips-Head Drill Tips	1/2" Carbide Drill Bit (Masonry Bit)
Slotted-Head Drill Tips	Sandpaper (Various Grades)
Redwood Stain	Wood Putty
Gray Wash Stain	Rags



# ASSEMBLY INSTRUCTIONS

The following sections will tell you how to assembly your gazebo. If you have any questions, problems with material and/or parts, please contact your local retailer.

**(A)**

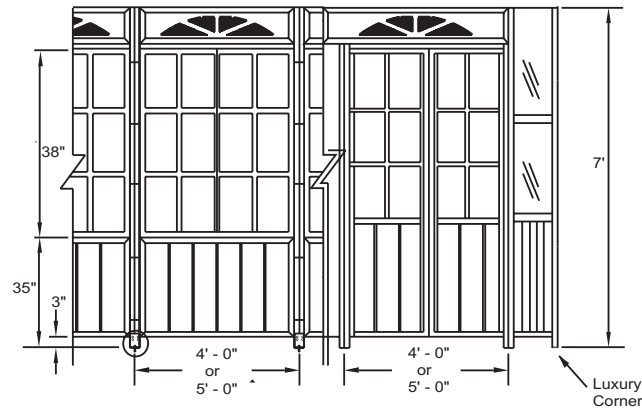

## Wall Panel Assembly

**NOTE:** Please follow the written steps in conjunction with the figures that are shown.

1. Stand two panels up side by side. Attach the panels together using 5 drywall screws (**Figure 2A**).
2. Repeat this step until all the panels are attached. **Figure 2B** will show you which order to go in.

**NOTE:** The rounded corners attach to the wall panels the same way, with 5 drywall screws. The owner must use care when securing the the wall panel and rounded corner together, as any damage incurred during assembly is not covered by the warranty.

**(B)**

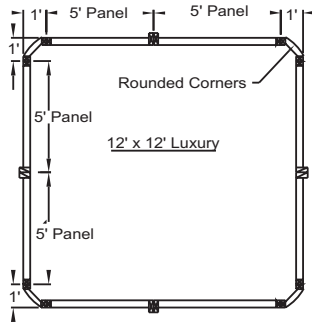
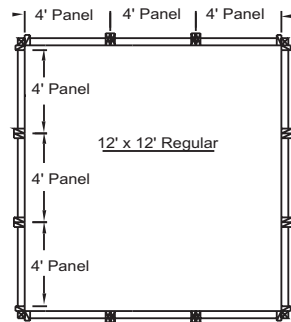

TOP VIEW OF WALL PANELS

**NOTE:** Rounded corners only come on the Luxury model.

**Figure 2A.** Wall Panel Assembly

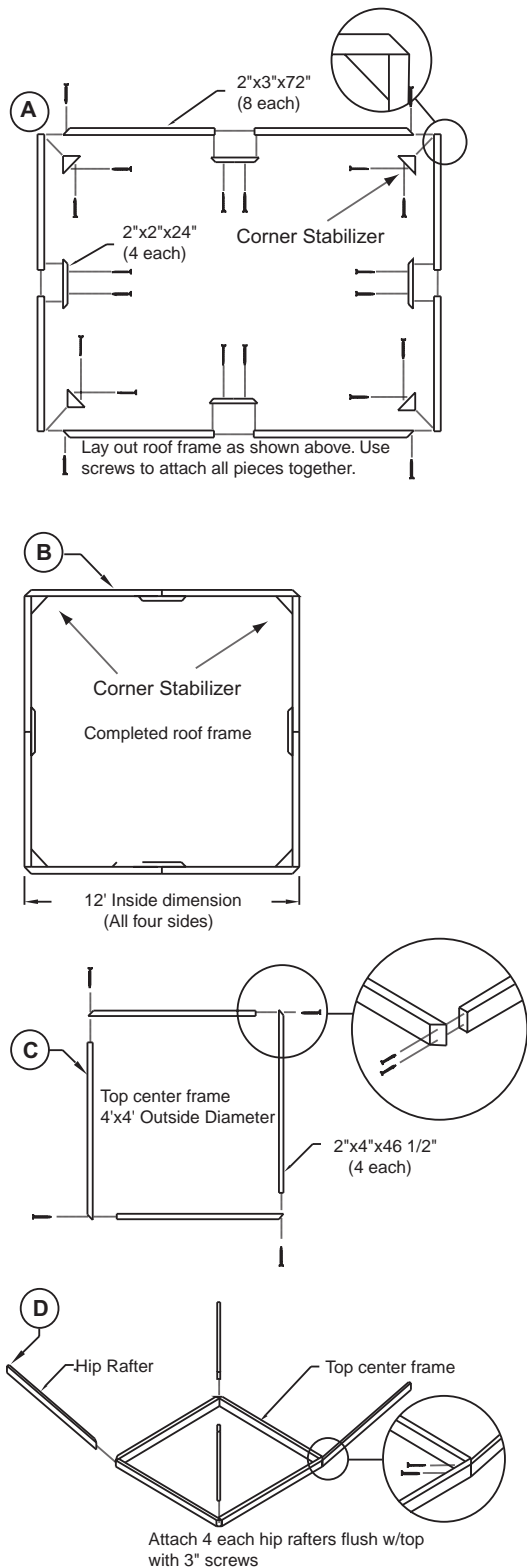

**Figure 3. Roof Frame Assembly**

### Roof Frame Assembly

When assembling the roof frame, it is recommended that you lay everything out and assemble it on a flat surface. It is also recommended that there be another person available when installing the roof frame on to the gazebo walls.

**NOTE:** Check the parts list that came with your gazebo and make sure that all the parts are present. Also, please follow the written steps in conjunction with the figures that are shown.

1. Take eight 2"x4"x72" pieces of wood and lay them out on the ground (**Figure 3A**), in effect making a square.
2. Use the provided drywall screws to attach all the pieces together. When complete, the outside diameter should measure 12'x12' (**Figure 3B**).
3. Place corner stabilizer (4 each) and attach in each corner (**Figure 3B**) using drywall screws.
4. Attach each corner together with the provided screws, making sure to keep the 45° corners pointing outward (**Figure 3C - insert**). This is the top center frame.
5. Take the hip rafters (4 each) and attach them to each corner of the top center frame. Make sure that the 45° corner matches the 45° end on the hip rafters (**Figure 3D**).

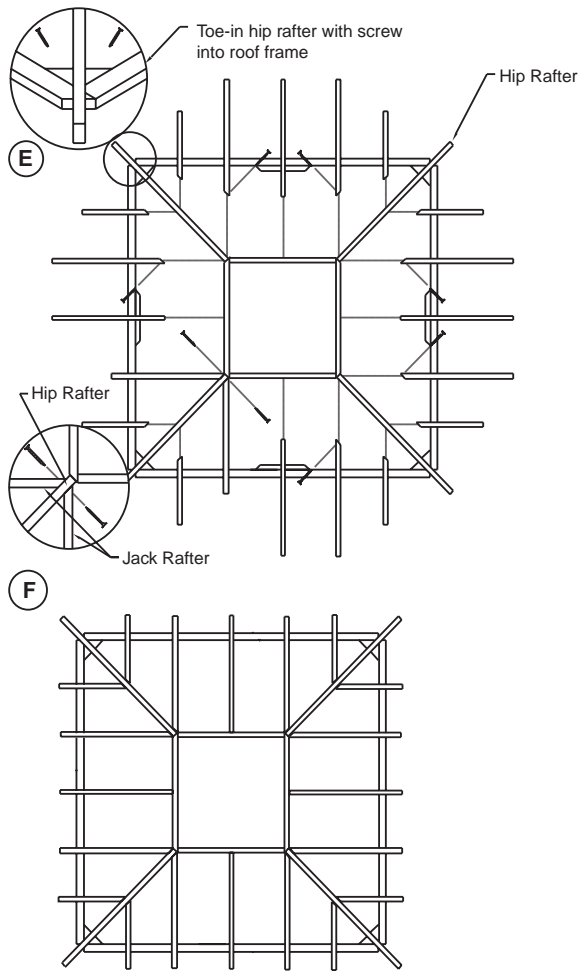

6. Take 4 common rafters and attach them to the middle of each side of the top center frame assembly (**Figure 3E**). Use the toe-in method (**see inset**).
7. With the common rafters now installed, attach the the remaining jack rafters using the toe-in method. Make sure that each jack rafter is spaced evenly apart. This will ensure sufficient anchoring points for the roof panels (**Figure 3E**).
8. **Figure 3F** shows what the roof frame will look like when it is completed.

**NOTE:** It is recommended that you have an assistant for the following step.

9. Place the assembled roof section on top of the wall panel assembly. Anchor the roof section by using drywall screws (**Figure 3G**).

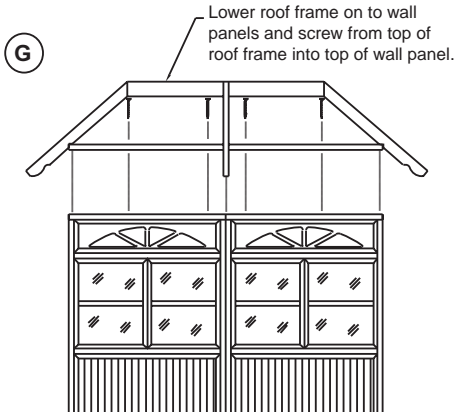

**Figure 3. Roof Frame Assembly**

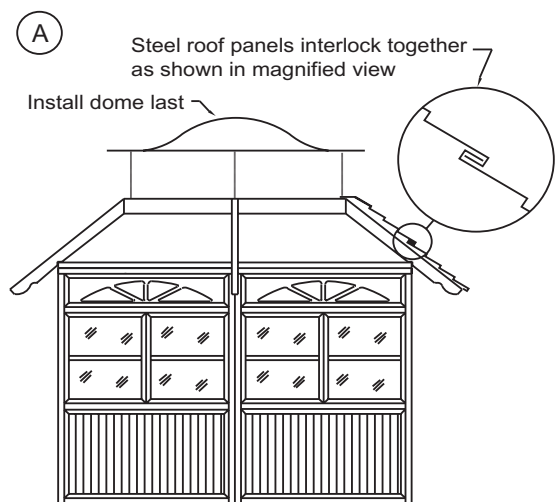

### Dome Installation

**NOTE:** The final steps of the gazebo assembly will require the use of a ladder.

1. Set the dome light assembly into the dome housing (**Figure 4A**).
2. From the inside the gazebo secure the dome assembly to the roof assembly using the dome brackets and drywall screws (**Figure 4B**). There will be four dome brackets that will connect to each side of the dome frame.

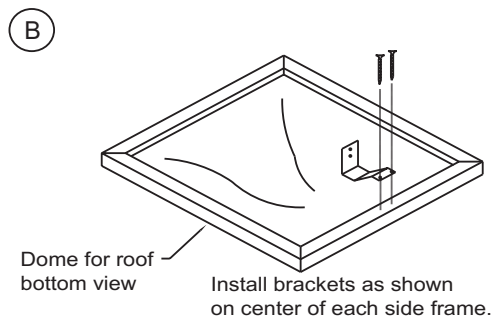

**Figure 4.** Dome Installation

# CLEANING, MAINTENANCE AND TROUBLESHOOTING

## Cleaning

Your gazebo was designed with low cleaning and maintenance in mind. We recommend that the gazebo be cleaned at least twice a month (or more, if needed). When cleaning your gazebo, cleaning solvents are not recommended. Using a sponge and water will be fine. For ground-in dirt and grime, please refer to the following section.

## Maintenance

Maintaining your gazebo will be an easy task. We recommend that every six months you should do an inspection of the wood on your gazebo. Take note of any deformities in the wood (i.e. cracking, peeling, dirt, grime, etc.). It is recommended that you spot sand these areas with 120-grit sandpaper. When complete, wipe these areas clean with a damp rag.

When dry, you must apply a coat of stain to the sanded area. Wipe the stained area clean and reapply until the sanded area matches the rest of the gazebo.

**NOTE:** An 8oz. can of stain will be supplied with each gazebo. To replace the can of stain, please contact your local Cal Enclosures dealer.

**NOTE:** On models that have plexi-glass windows, the use of a cheese cloth and warm water should be used. These windows are made of plexi-glass and do not hold up well under the abrasive conditions that many commercial cleaners generate.

## TROUBLESHOOTING PROCEDURES

**Q: Why will the windows on the gazebo not stay open/closed?**

**A:** This is most likely due to the fact that your foundation is not level. Foundations will most likely have a 1/4" pitch for drainage reasons. To rectify this problem, the gazebo must be shimmed on the low side. Using a standard level, shim the low side so that the gazebo is level.

**Q: Why won't the roof panels not sit correctly on the roof frame?**

**A:** Check the top plate on the top center frame and make sure it is level and installed correctly.

**Q: My roof and wall panels are lining up correctly and there are small gaps in the joint seams. Why is this?**

**A:** The main support post is not "plumb" (meaning vertically level). You must go back and make sure that the main support post is plumb. Also, you must make sure that each of your main support beams is "square" in relation to the main support post (meaning that there is a 90° angle when the main support post and the main support beam intersect).

## APPENDIX

The items that will be covered in this section will consist of the following:

Accessories

Part Numbers

Notes

In order for your retailer to expedite your order, for parts and accessories, it is recommended that you have the information that you attained in the Set-Up and Delivery section. Customer Service will want all this information for warranty purposes.

## ACCESSORIES

The following is a list of all the accessories that you can use with your Cal Spa Creative Wood Designs Gazebo. If you wish to order an accessory, feel free to contact your dealer with the desired part name and part number, or visit [www.calspas.com](http://www.calspas.com).

<b>Description</b>	<b>Size</b>	<b>Wood</b>	<b>Part Number</b>	
			<b>Cal Stone</b>	<b>Deluxe Stone</b>
Bar Top	11'	WOOD289	WOOD289CS	WOOD289DS
	80'	WOOD288	WOOD288CS	WOOD288DS
	75'	WOOD287	WOOD287CS	WOOD287DS
Round Corner		WOOD199	WOOD199CS	WOOD199DS
Storage Bench	11'	WOOD905	WOOD905CS	WOOD905DS
	80'	WOOD902	WOOD902CS	WOOD902DS
	75'	WOOD901	WOOD901CS	WOOD901DS
Crescent S/B		WOOD900	WOOD900CS	WOOD900DS
Bar Corbel		WOO270405060		
Bench Leg		WOO27405020		
Bar Stool		WOOD127	WOOD127CS	WOOD127DS
Surround Step	11'	WOOD296		
	80'	WOOD297		
	75'	WOOD298		
Crescent Step		WOOD214		
30' Step		WOOD107		
30" Storage Step w/Box		WOOD133		
5' Step		WOOD109		
5' Step Storage w/Box		WOOD134		
30" Step w/Handrail		WOOD107-2		
Round Planter		WOOD101		
Square Planter		WOOD100		
Crown Planter		WOOD189		
Octagon Planter		WOOD148		
Crescent Planter		WOOD168		
Bench	11'	WOOD923	WOOD923CS	WOOD923DS
	80'	WOOD922	WOOD922CS	WOOD922DS
	75'	WOOD921	WOOD921CS	WOOD921DS
Crescent Bench		WOOD920	WOOD920CS	WOOD920DS
Privacy Panel		WOOD183		
30" Step (3 tier)	30"	WOOD108		
30" Step (3 Tier with Handrail)	30"	WOOD108-2		
Towel/Wine Glass Rack	4'	WOOD113		
Towel/Wine Glass Rack	5'	WOOD113-5		
Wine Glass Hanger		WOOD114		
Towel Tree		WOOD169		
Kidzone Playhouse		KDZ100		

**10' x 10' PLANTATION GAZEBO**

<b>Item Number</b>	<b>Description</b>	<b>Part Number</b>	<b>Quantity</b>
1	36"x84' Deck Assembly	WOO27302820	2
2	36"x36" Deck Assembly	WOO27303080	1
3	4' Ultra Louver Wall Panel Complete		6
4	5' Ultra Louver Door Complete	WOO27107460	1
5	#5 Metal Roof Panel (L)	WOO27200760	4
6	#5 Metal Roof Panel (R)	WOO27200780	4
7	53" Hip Rafter, No Slider	WOO27207740	4
8	40 1/2" Common Rafter, No Slider	WOO27208100	12
9	2"x4"x70 1/2" M1 Moon Roof, No Slider	WOO27214720	4
10	2"x4"x 96" Cross Ties	WOO27211320	1
11	2"x3"x60" Header Boards	WOO27107680	8
12	2"x2"x24" M2 Corner Stabilizer	WOO27106900	4
13	2"x4"x6 1/2" Mitered Both Ends	WOO27200600	4
14	Round Corner Columns		3
15	36" Molding Center Metal	HAR13900160	4
16	47 1/2" Corner Molding	HAR13900180	4
17	12" Coil Strap	HAR13900070	2
18	8 x 1 1/2" Screw for Molding	HAR13200050	35
19	8 x 2 1/2" Screw SQ Drive Drywall	HAR13201150	125
20	Dome Bracket	HAR13800020	4
21	8 x 3" Screw SQ Drive Drywall	HAR13201140	25
22	8 x 1" Screw for Metal Roof	HAR13200200	100
23	78"x78" Dome w/Frame	WOO27211880	1
24	3' Ultra Louver Wall Panel		1



# NOTES

\$5.00



# 2004 Owner's Manual

## CHALET GAZEBO

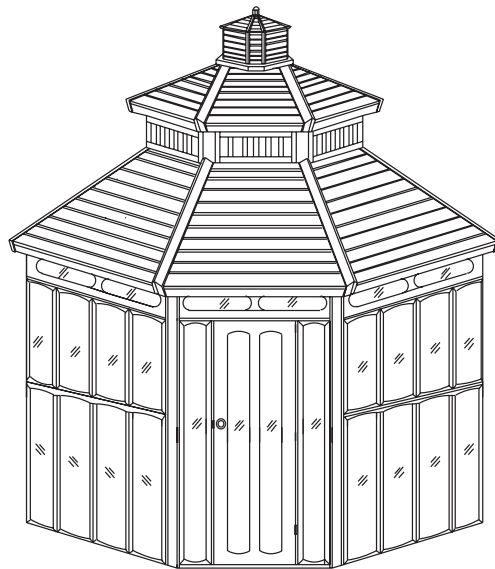

Duplication without written consent is strictly prohibited.  
This Owner's Manual is for gazebos manufactured after January 1, 2004  
Due to continuous improvement programs, all models, operation, and/or specifications are subject to change without prior notice.  
LTR17000772

# Table of Contents

Benefits of Owning a Gazebo .....	2
Safety Instructions .....	3
Contact Information.....	4
Warranty Information .....	4
Set-up and Delivery .....	5
Assembly .....	9
Cleaning, Maintenance and Troubleshooting .....	16
Accessories .....	17
Parts List.....	18
Notes.....	19

### BENEFITS OF OWNING A GAZEBO

Owning a gazebo allows you to have a wonderful place to unwind after a long day of work. It offers a place for you to socialize with family and friends. It offers great cover in the event that you purchase a bar-b-que and/or spa. Owning a gazebo can add character to your patio and/or yard. You can use a gazebo for whatever best suits your needs.

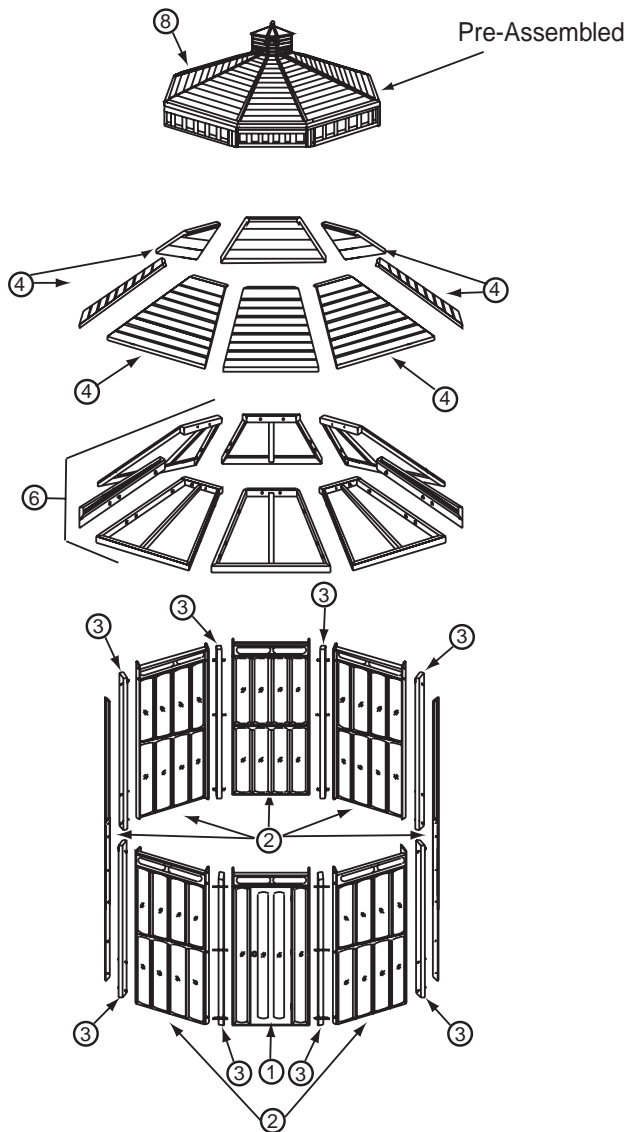

**Figure 1.** Chalet Gazebo (Octagon Series)

**NOTE:** Please refer to the parts list located at the end of this manual for a full description on each item number shown above.

## **SAFETY INSTRUCTIONS**

### **Carefully read and follow all safety instructions.**

1. When installing and assembling your gazebo, it is recommended that 2 or more people be involved.
2. Do not use the unit during an electrical storm, as there is a remote chance of getting struck by lightning.
3. Do not climb on top of the gazebo. While the gazebo is made out of high-quality wood and is extremely durable, the gazebo is not meant to be used as a jungle gym. Thus, falling off of the gazebo while climbing on it can result in serious injury, possibly even death.
4. Do not attempt any repair without consulting the manufacturer first. Unauthorized repair attempts will void the manufacturer's warranty.

**Save this information.**

## CONTACT INFORMATION

For customer service, please contact your authorized dealer immediately. If you need additional information and/or assistance, please contact:

C.A.I. Customer Service Department  
1462 East Ninth Street  
Pomona, CA 91766  
Toll Free: 1-800-CAL-SPAS  
Fax: 1-909-629-3890

## WARRANTY INFORMATION

See your Cal Enclosures dealer for a copy of the applicable warranty, details and any questions you may have regarding the warranty coverage on your gazebo.

### Warranty Limitations

The Limited Warranty is void if the gazebo has been subject to negligence, alteration, misuse, abuse, repairs by non- C.A.I. authorized representatives, acts of God and any other cases beyond the control of C.A.I. Examples of common acts invalidating this warranty include but are not limited to:

Use of the gazebo in a non-residential application.

Scratches caused by normal use.

Damage caused by extreme weather conditions. (Hot, cold, etc.)

Damage caused by dirt, sand, and/or water damage.

Damage caused by continuous operation of the gazebo with either known or unknown problems.

Damage caused by direct sunlight.

Damage caused as a result of failure to follow the assembly instructions as defined in this Owner's Manual.

This Limited Warranty applies only to gazebos normally used for personal, family, or household purposes.

This Limited Warranty specifically excludes commercial gazebos.

### Warranty Exclusions

C.A.I. warrants the gazebo from defects in material and workmanship for a period of 90 days from the original date of purchase.

**REMINDER: PLEASE DO NOT FORGET TO REGISTER YOUR NEW PRODUCT AT [WWW.CALSPAS.COM](http://WWW.CALSPAS.COM)**

## DELIVERY AND SET-UP

Please make a record of the following. It will be valuable if service is required.

Gazebo Model: \_\_\_\_\_

Gazebo Serial Number: \_\_\_\_\_

Date Purchased: \_\_\_\_\_

Date Installed: \_\_\_\_\_

Gazebo Dealer's Phone Number: \_\_\_\_\_

Gazebo Dealer's Address: \_\_\_\_\_

Most cities and counties require permits for exterior construction and electrical circuits. In addition, some communities have codes requiring residential barriers such as fencing and/or self-closing gates on property to prevent unsupervised access to the property by children under the age of 5. Your dealer can provide information on which permits may be required and how to obtain them prior to the delivery of your equipment.

### Planning the Best Location For Your Gazebo

Here are some of the things that you will need to consider when determining where to locate your new gazebo.

#### How Will You Use Your Gazebo?

How you intend to use your gazebo will help you determine where you should position it. For example, will you use your gazebo for recreational purposes? If your gazebo is mainly used for family functions, be sure to leave plenty of room around it for activity. In any case dealing in how it is to be used, you'll probably want to create a specific mood around it.

#### Consider Your Privacy

In a cold- weather climate, bare trees won't provide much privacy. Think of your gazebos surroundings during all seasons to determine your best privacy options. Consider the view of your neighbors as well, when you plan the location of your gazebo.

#### Provide A View With Your Gazebo

Think about the direction you will be facing when sitting in your gazebo. Do you have a special landscaped area in your yard that you find enjoyable? Perhaps there is an area that catches a soothing breeze during the day and lovely sunset in the evening. Consider these things when you plan your location.

## PREPARING A GOOD FOUNDATION

Your gazebo needs a solid and level foundation. The area that it sits on must be able to support the weight of the gazebo and the occupants who use it. If the foundation is inadequate, it may shift or settle after the gazebo is in place, causing stress that could alter the structures figure and possibly split the wooden joints.

**NOTE:** Damage caused by inadequate or improper foundation support is not covered by the warranty. It is the responsibility of the gazebo owner to provide a proper foundation for the gazebo.

Place the gazebo on an elevated foundation (preferably a 3” concrete slab).

- \* If you are installing your gazebo on an elevated wood deck or other structure, it is highly recommended that you consult a structural engineer or contractor to ensure the structure will support the weight.
- \* It is strongly recommended that a qualified, licensed contractor prepare the foundation for your gazebo.

## Your Cal Enclosures Retailer Can Help You With Foundations And More

Your retailer has a wealth of information and experience about how to get the most out of your gazebo. Your gazebo retailer also has a full line of accessories that are engineered to compliment your gazebo.

**NOTE:** It is strongly advised that you have a licensed professional install the foundation for your new gazebo. It is imperative that the foundation is level, as any damage that occurs due to an uneven foundation is not covered by the warranty.

## Size Specifications

<u>Model</u>	<u>Length</u>	<u>Width</u>
Frontier Gazebo	8'	8'
	10'	8'
	12'	8'
Cottage Gazebo	8'	8'
Cabana Gazebo	7'	7'
	7.5'	7.5'
	8'	8'
Northeast Gazebo	7.5'	7.5'
	8'	8'
Lattice Wall Gazebo	7'	7'
	7.5'	7.5'
	8'	8'
	12'	8'
	16'	8'
	10'	10'
	12'	10'
16'	10'	
	12'	12'



<b><u>Model</u></b>	<b><u>Length</u></b>	<b><u>Width</u></b>
Lattice Wall Gazebo (continued)	12'	12'
	16'	12'
	10' (Octagon)	10'
	12' (Octagon)	12'
Plexi Wall Gazebo	7'	7'
	7.5'	7.5'
	8'	8'
	12'	8'
	16'	8'
	10'	10'
	12'	10'
	12'	12'
	16'	12'
	10' (Octagon)	10'
	12' (Octagon)	12'
	15' (Octagon)	15'
18' (Octagon)	18'	
Luxury Wall Gazebo	7'	7'
	7.5'	7.5'
	8'	8'
	12'	8'
	16'	8'
	10'	10'
	12'	10'
	16'	10'
	12'	12'
	16'	12'
Savannah Wall Gazebo	12'	8'
	10'	10'
	12'	10'
	16'	10'
	12'	12'
	16'	12'
	10' (Octagon)	10'
	12' (Octagon)	12'
Timberline Gazebo	12'	8'
	10'	10'
	12'	10'
	12'	12'
	16'	12'

<b><u>Model</u></b>	<b><u>Length</u></b>	<b><u>Width</u></b>
Lighthouse Gazebo	10'	10'
	12'	10'
	12'	12'
	16'	12'
Plantation Gazebo	10'	10'
	12'	10'
	12'	12'
	16'	12'
<b>Chalet Gazebo</b>	<b>12'(Octagon)</b>	<b>12'</b>
	<b>14'(Octagon)</b>	<b>14'</b>
	<b>16'(Octagon)</b>	<b>16'</b>
Victorian Gazebo	12'(Octagon)	12'
	14' (Octagon)	14'
	16' (Octagon)	16'

**NOTE:** The gazebo above that is listed in bold lettering is the gazebo that you purchased.

**NOTE:** For all gazebos, regardless of model, it is recommended that the foundation (concrete slab, railroad ties or pre-cast stepping stones) extend beyond the dimension of the gazebo. For example, if the gazebo you purchased is 12'x12', you will want your foundation to be 14'x14'. The reason for this is because it will be easier to maintain the area around the gazebo (mowing the lawn, edging, etc.) without damaging or scarring the gazebo. Also, in doing this, you will eliminate any potential problems, foundation-wise, in the future.

**NOTE:** This Owner's Manual applies to the various sizes that are included in the Chalet Gazebo line (12'x12', 14'x14' and 16'x16'). While the sizes will vary from gazebo to gazebo, the assembly instructions will be the same, unless otherwise noted.

## **Tools and Materials**

Utility Knife	25' Tape Measure
Cordless Drill	100' Extension Cord
1/8" Pilot Hole Drill Bit	1/2" Ratchet and Impact Drill
Electric Drill	9/16" Socket
Phillips-Head Drill Tips	1/2" Carbide Drill Bit (Masonry Bit)
Slotted-Head Drill Tips	Sandpaper (Various Grades)
Redwood Stain	Wood Putty
Gray Wash Stain	Rags

# ASSEMBLY INSTRUCTIONS

The following sections will tell you how to assembly your gazebo. If you have any questions, problems with material and/or parts, please contact your local retailer.

**IMPORTANT NOTE:** The assembly instructions contained in this manual are for the Chalet Gazebo that measures 16' x 16'. The assembly instructions will be the same for the 12' x 12' and 14' x 14' models. The only difference in the assembly of these three models is the amount of steps the owner must perform.

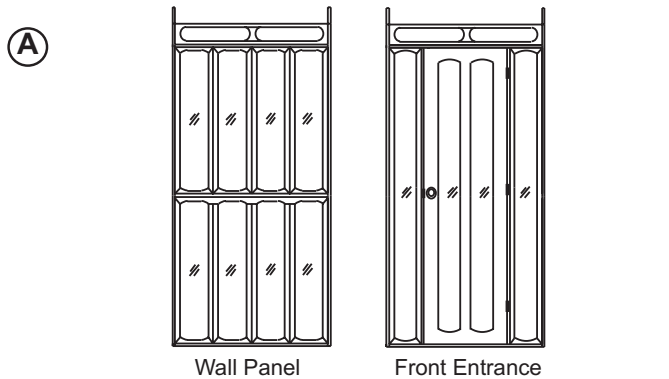

## Wall Panel Assembly

**NOTE:** Check the parts list that came with your gazebo and make sure that all the parts are present. Please follow the written steps in conjunction with the figures that are shown.

1. Stand panels up vertically with the flush side of the panel facing inward (fit panels together as shown in **Figure 2A**).
2. Drill holes in all 2"x4" boards. The holes have already been drilled for the wall panels. Line up the holes and mark the 2"x4" and drill accordingly.
3. Insert the provided 7"x5/16" threaded rod and washer into the pre-drilled holes and tighten with the nut (**Figure 2B**).
4. Repeat this step until wall panel assembly is complete (**Figure 2C**).

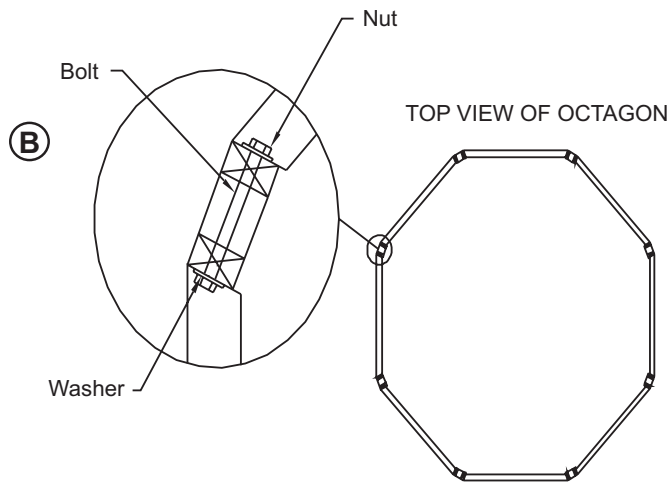

**Figure 2. Wall Panel Assembly**

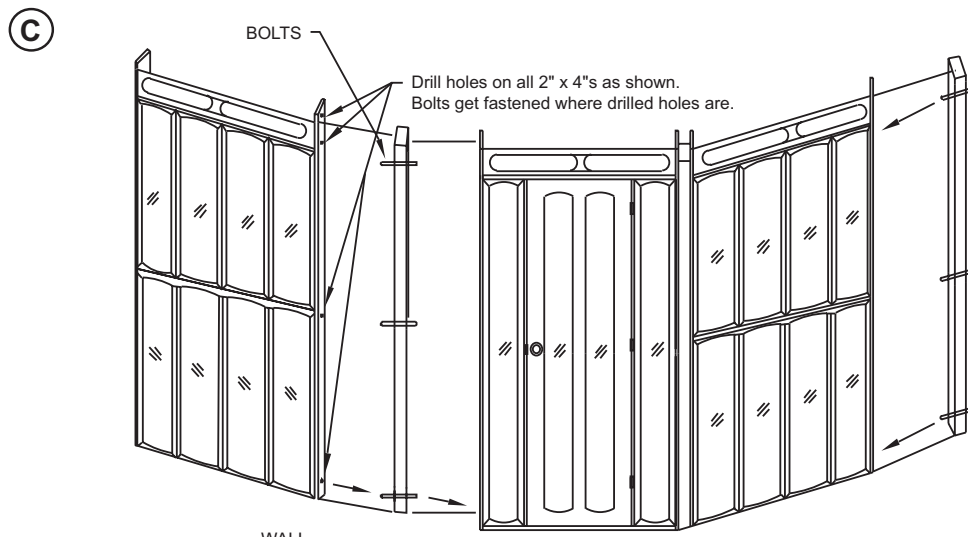

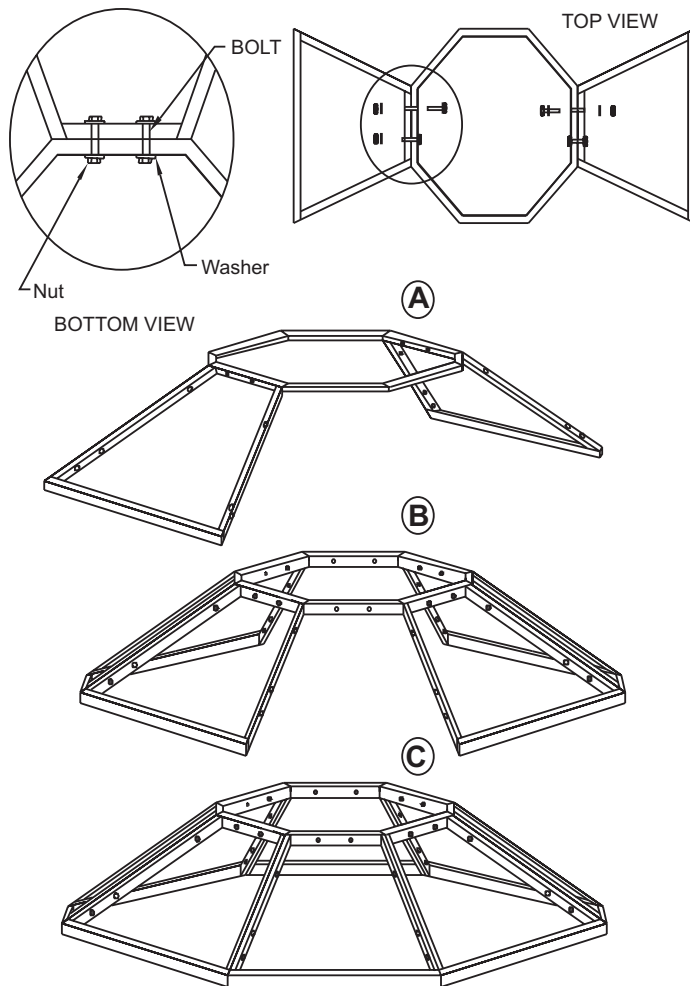
ASSEMBLY INSTRUCTIONS  
COMPOSITION ROOF

**Figure 3.** Composition Roof Assembly

## COMPOSITION ROOF ASSEMBLY

**NOTE:** Check the parts list that came with your gazebo and make sure that all the parts are present. Also, please follow the written steps in conjunction with the figures that are shown.

1. Lay the 8-sided main roof support section flat on the ground.
2. Take one 4-sided roof frame section and place the narrow end against the 8-sided main roof support section.
3. Using the provided hardware, insert two 3/8"x16"x1/2" hex-head cap bolts through the pre-drilled holes (**Figure 3A**) and tighten with the washer and nut.
4. Repeat this step until roof frame is complete.

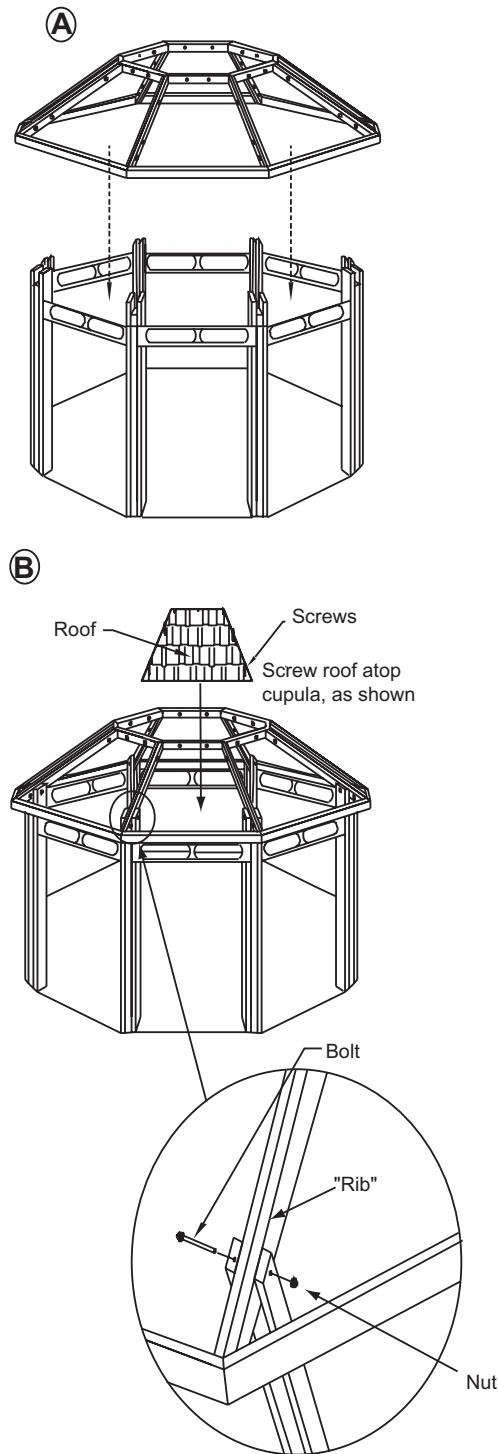

**NOTE:** It is strongly recommended that two people perform the following steps, as the roof assembly is extremely heavy.

5. Having already assembled the wall panels, and now the roof frame, pick up the roof assembly and place it on top of the wall panel assembly (**Figure 4A**).
6. The top of each wall panel support has a slot (8 total). Place each "rib" of the roof frame into each one of these slots (**Figure 4B**).
7. Using the provided hardware, insert a 5/16"x18"x3 1/2" bolt into the pre-drilled hole that is located on the slotted end of the wall panel support and the "rib" section of the roof frame.
8. Repeat this step until the roof frame is securely attached to the wall panel assembly.
9. Take one 4-sided section of shingled roof and attach it to the corresponding location on top of the roof frame (**Figure 4C**).

**Figure 4.** Chalet Assembly Instructions

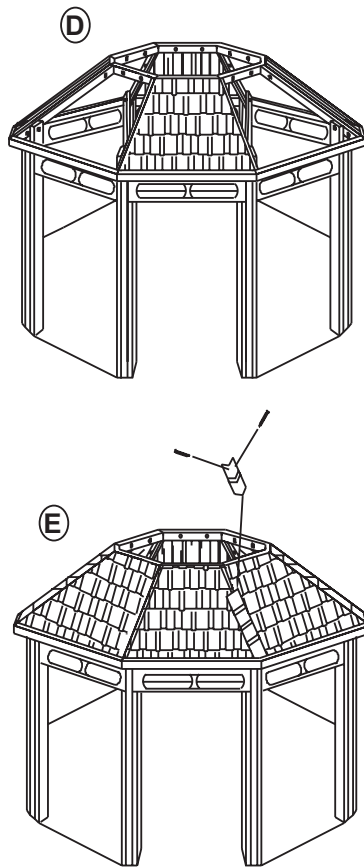

10. Take one 4-sided section of shingled roof and attach it to the corresponding location on top of the roof frame (**Figure 4D**).
11. Attach each individual corner roof shingle. Start at the bottom and work your way to the top, securing each shingle as you go (**Figure 4E**).
12. Repeat this step until the shingled roof sections are securely attached to the roof.

**Figure 4.** Chalet Assembly Instructions

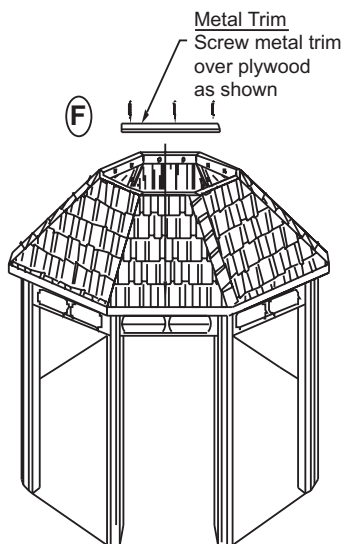

12. Using the provided metal trim, slide the non-decorative piece between the shingle and plywood layers (**Figure 4C**).
13. Attach the metal trim, using the provided metal screws, by screwing it into the plywood layer (use the “toe-in” method: attach the metal trim with a 3” screw, at a 45° angle, through the the 2”x4” into the plywood layer - **Figure 4D**).
14. Repeat this step until the metal trim is securely attached to the roof.

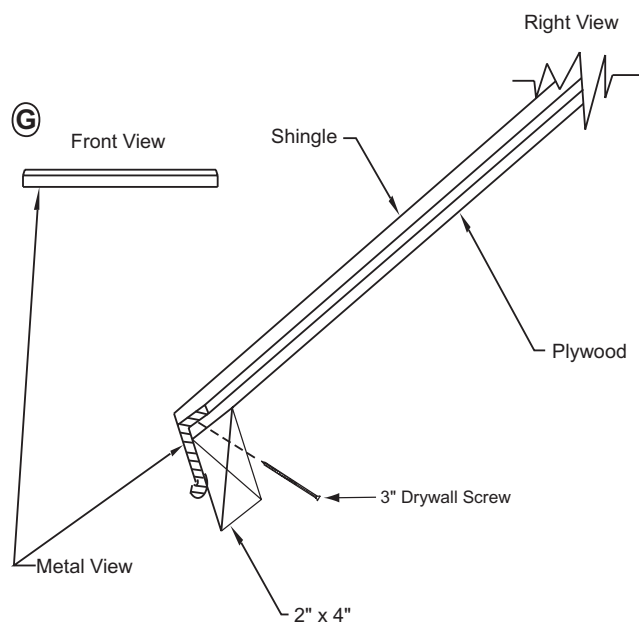

**Figure 4.** Chalet Assembly Instructions

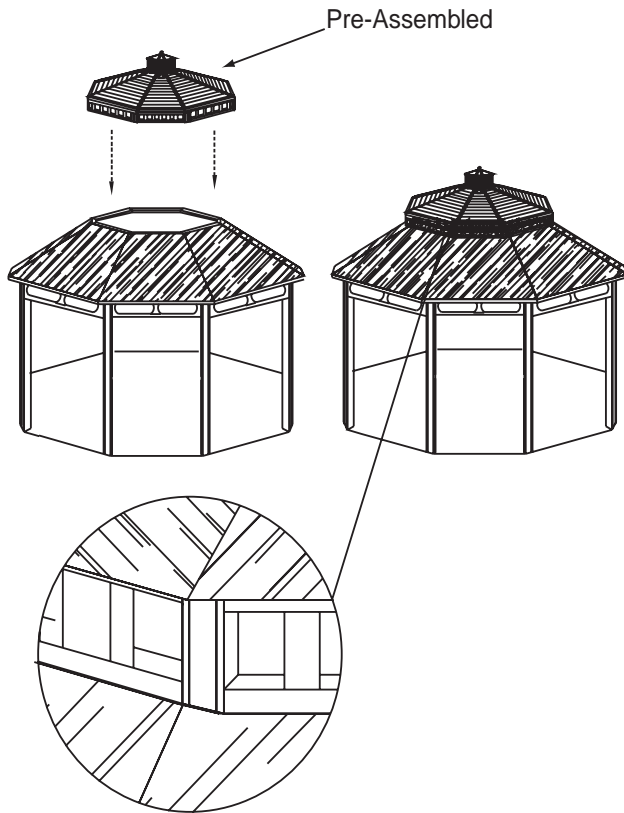

**Figure 5.** Chalet Assembly Instructions

## FINAL ASSEMBLY

**NOTE:** Cupola assembly comes pre-assembled.

**NOTE:** It is strongly recommended that two people complete the following steps, as the cupola roof assembly is heavy and awkward.

1. Take the assembled cupola and place it on the top of the gazebo roof (**Figure 5**).
2. Using the provided hardware, attach each triangular-shaped shingle to the cupola roof section. Repeat this step until all of the shingle sections are in place and securely attached to the roof (**Figure 5**).
3. Attach each roof corner shingle. Start at the bottom of the cupola and work up to the top, securing each shingle as you go (**Figure 5**). Repeat this step until all of the corner shingles are in place.



Top view of the gazebo with the benches in place.

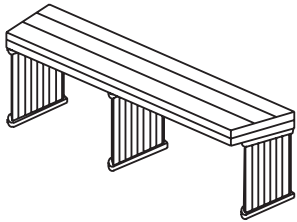
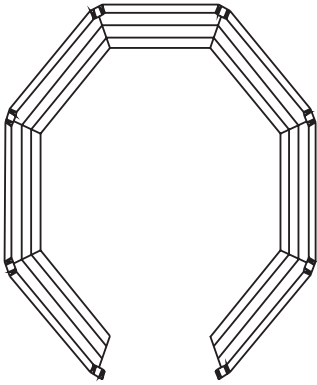

**A**

Attach bench supports as shown below.

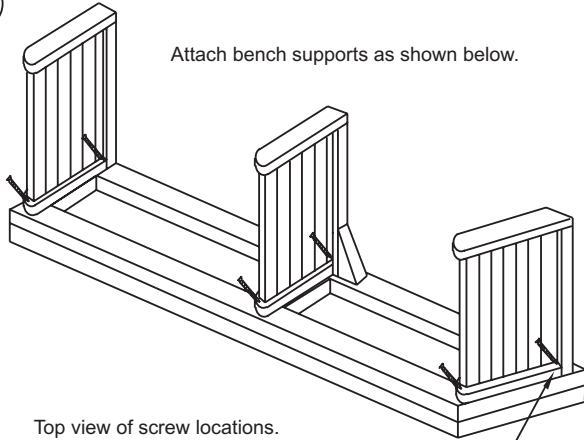

Top view of screw locations.

**B**

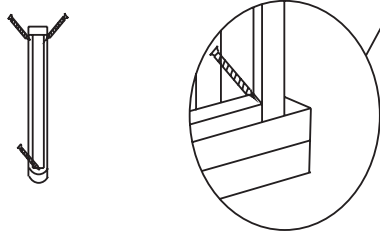

**Figure 6. Bench Assembly**

### BENCH ASSEMBLY

1. After checking to see if all the parts are present, lay the top piece of the bench flat on the ground (smooth-side down). Locate the bench supports (**Figure 6A**).
2. Screw in each bench support (**Figure 6B**) with the provided screws.
3. Repeat this step until all of the benches are complete.

## CLEANING AND MAINTENANCE

### Cleaning

Your gazebo was designed with low cleaning and maintenance in mind. We recommend that the gazebo be cleaned at least twice a month (or more, if needed). When cleaning your gazebo, cleaning solvents are not recommended. Using a sponge and water will be fine. For ground-in dirt and grime, please refer to the following section.

### Maintenance

Maintaining your gazebo will be an easy task. We recommend that every six months you should do an inspection of the wood on your gazebo. Take note of any deformities in the wood (i.e. cracking, peeling, dirt, grime, etc.). It is recommended that you spot sand these areas with 120-grit sandpaper. When complete, wipe these areas clean with a damp rag.

When dry, you must apply a coat of stain to the sanded area. Wipe the stained area clean and reapply until the sanded area matches the rest of the gazebo.

**NOTE:** An 8oz. can of stain will be supplied with each gazebo. To replace the can of stain, please contact your local Cal Enclosures dealer.

**NOTE:** On models that have plexi-glass windows, the use of a cheese cloth and warm water should be used. These windows are made of plexi-glass and do not hold up well under the abrasive conditions that many commercial cleaners generate.

## TROUBLESHOOTING PROCEDURES

**Q: Why will the windows on the gazebo not stay open/closed?**

**A:** This is most likely due to the fact that your foundation is not level. Foundations will most likely have a 1/4" pitch for drainage reasons. To rectify this problem, the gazebo must be shimmed on the low side. Using a standard level, shim the low side so that the gazebo is level.

**Q: Why won't the roof panels not sit correctly on the roof frame?**

**A:** Check the top plate on the top center frame and make sure it is level and installed correctly.

**Q: My roof and wall panels are not lining up correctly and there are small gaps in the joint seams. Why is this?**

**A:** The main support post is not "plumb" (meaning vertically level). You must go back and make sure that the main support post is plumb. Also, you must make sure that each of your main support beams is "square" in relation to the main support post (meaning that there is a 90° angle when the main support post and the main support beam intersect).

## ACCESSORIES

The following is a list of all the accessories that you can use with your Cal Spa Creative Wood Designs Gazebo. If you wish to order an accessory, feel free to contact your dealer with the desired part name and part number, or visit [www.calspas.com](http://www.calspas.com).

<u>Description</u>	<u>Size</u>	<u>Wood</u>	<u>Part Number</u>	
			<u>Cal Stone</u>	<u>Deluxe Stone</u>
Bar Top	11'	WOOD289	WOOD289CS	WOOD289DS
	80'	WOOD288	WOOD288CS	WOOD288DS
	75'	WOOD287	WOOD287CS	WOOD287DS
Round Corner		WOOD199	WOOD199CS	WOOD199DS
Storage Bench	11'	WOOD905	WOOD905CS	WOOD905DS
	80'	WOOD902	WOOD902CS	WOOD902DS
	75'	WOOD901	WOOD901CS	WOOD901DS
Crescent S/B		WOOD900	WOOD900CS	WOOD900DS
Bar Corbel		WOO270405060		
Bench Leg		WOO27405020		
Bar Stool		WOOD127	WOOD127CS	WOOD127DS
Surround Step	11'	WOOD296		
	80'	WOOD297		
	75'	WOOD298		
Crescent Step		WOOD214		
30' Step		WOOD107		
30" Storage Step w/Box		WOOD133		
5' Step		WOOD109		
5' Step Storage w/Box		WOOD134		
30" Step w/Handrail		WOOD107-2		
Round Planter		WOOD101		
Square Planter		WOOD100		
Crown Planter		WOOD189		
Octagon Planter		WOOD148		
Crescent Planter		WOOD168		
Bench	11'	WOOD923	WOOD923CS	WOOD923DS
	80'	WOOD922	WOOD922CS	WOOD922DS
	75'	WOOD921	WOOD921CS	WOOD921DS
Crescent Bench		WOOD920	WOOD920CS	WOOD920DS
Privacy Panel		WOOD183		
30" Step (3 tier)	30"	WOOD108		
30" Step (3 Tier with Handrail)	30"	WOOD108-2		
Towel/Wine Glass Rack	4'	WOOD113		
Towel/Wine Glass Rack	5'	WOOD113-5		
Wine Glass Hanger		WOOD114		
Towel Tree		WOOD169		
Kidzone Playhouse		KDZ100		

## PARTS LIST

### 12'x12' Octagon Composition Roof

<u>Item Number</u>	<u>Description</u>	<u>Part Number</u>	<u>Quantity</u>
1	48"x93 1/2" Chalet Wall Panel	WOO27102595	7
2	48"x93 1/2" Chalet Wall Panel	WOO27102598	1
3	4"x4"x90"	WOO27211260	8
4	59"x50 1/2" Roof Panel w/ Shingles	WOO27216812	8
5	58 1/2"x58 1/2" Top Center Frame	WOO27211481	1
6	59"x49" Roof Frame	WOO27216814	8
7	Pagoda Wall Frame	WOO27215141	1
8	Pagoda Roof w/ Shingles	WOO27206345	8
9	Pagoda Roof Frame	WOO27206348	1
10	30" Metal Flashing	WOO27520021	8
11	59 1/2" Metal Flashing	WOO27520022	8
12	2"x6"x45 7/8" M2 22 1/2" Top Rail	WOO27402702	7
13	Ridge Grip Shingle Molding	WOO27904346	80
14	Philbugle Head 8"x5/8"	HAR13200010	60
15	5/16"x18"x3 1/2" Hex Head Cap Screw	HAR13201051	20
16	5/16" USS Flat Washer	HAR13500170	40
17	3/8"x16"x4 1/2" Hex Head Cap Screw	HAR13300150	20
18	1/4" USS Flat Washer	HAR13500040	112
19	8x2 1/2" SQ. Drywall Screw	HAR13201150	125
20	8x3" SQ. Drywall Screw	HAR13201140	40
21	3/8" 16 Nut	HAR13400050	20
22	5/16"x7 Screw/Lag Hex	HAR13200481	36
23	5/16" Nut	HAR13201180	92
24	8oz. Can of Touch Up Paint/ Stain	CHE07000575	1
25	Warranty & Registration Card	LTR17001970	1
26	Copula	WOO27215150	1
27	4' Bench Top For 12' Oct-Gazebo	WOO27300197	7
28	System Bench Support Leg	WOO27405020	21
29	2"x4"x6 1/2" Corner Stabilizer	WOO27200600	21
30	12' Victorian Deck	WOO27305872	8
31	Center Octagon Deck	WOO27305662	1

### Solid Roof

32	Roof Panel Solid	WOO27216810	8
----	------------------	-------------	---

# NOTES

\$5.00



# 2004 Owner's Manual

## VICTORIAN GAZEBO

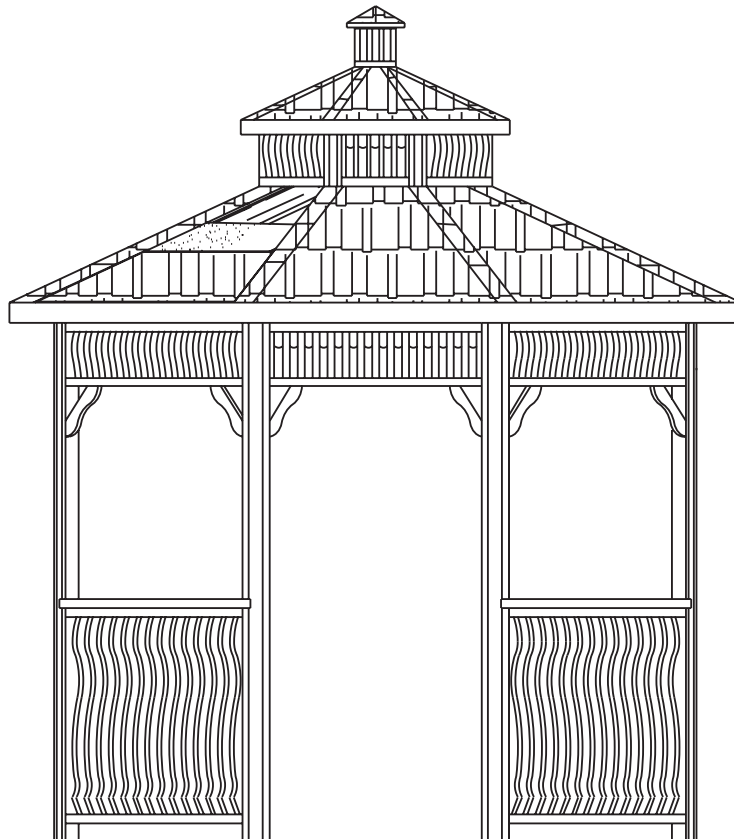

Duplication without written consent is strictly prohibited.

This Owner's Manual is for gazebos manufactured after January 1, 2004

Due to continuous improvement programs, all models, operation, and/or specifications are subject to change without prior notice.

LTR17000784

# Table of Contents

Benefits of Owning a Gazebo .....	2
Safety Instructions .....	3
Contact Information.....	4
Warranty Information .....	4
Set-up and Delivery .....	5
Assembly .....	9
Cleaning, Maintenance and Troubleshooting .....	15
Appendix .....	16
Accessories .....	17
Parts List.....	18
Notes.....	19

### BENEFITS OF OWNING A GAZEBO

Owning a gazebo allows you to have a wonderful place to unwind after a long day of work. It offers a place for you to socialize with family and friends. It offers great cover in the event that you purchase a bar-b-que and/or spa. Owning a gazebo can add character to your patio and/or yard. You can use a gazebo for whatever best suits your needs.

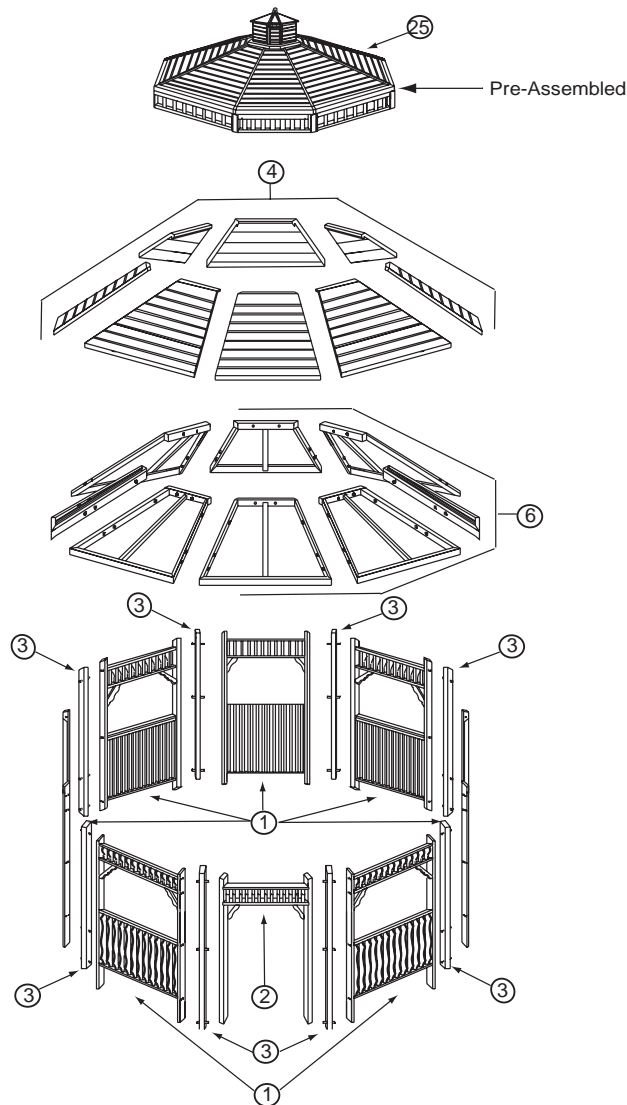

**Figure 1.** Victorian Gazebo (Octagon Series)

**NOTE:** Please refer to the parts list located at the end of this manual for a full description on each item number shown above.



## **SAFETY INSTRUCTIONS**

### **Carefully read and follow all safety instructions.**

1. When installing and assembling your gazebo, it is recommended that 2 or more people be involved.
2. Do not climb on top of the gazebo. While the gazebo is made out of high-quality wood and is extremely durable, the gazebo is not meant to be used as a jungle gym. Thus, falling off of the gazebo while climbing on it can result in serious injury, possibly even death.
3. Do not use the unit during an electrical storm. as there is a remote chance of getting struck by lightening.
4. Do not attempt any repair without consulting the manufacturer first. Unauthorized repair attempts will void the manufacturer's warranty.

**Save this information.**

## CONTACT INFORMATION

For customer service, please contact your authorized dealer immediately. If you need additional information and/or assistance, please contact:

C.A.I. Customer Service Department  
1462 East Ninth Street  
Pomona, CA 91766  
Toll Free: 1-800-CAL-SPAS  
Fax: 1-909-629-3890

## WARRANTY INFORMATION

See your Cal Spas Creative Wood Designs dealer for a copy of the applicable warranty, details and any questions you may have regarding the warranty coverage on your gazebo.

### Warranty Limitations

The Limited Warranty is void if the gazebo has been subject to negligence, alteration, misuse, abuse, repairs by non- C.A.I. authorized representatives, acts of God and any other cases beyond the control of C.A.I. Examples of common acts invalidating this warranty include but are not limited to:

Use of the gazebo in a non-residential application.

Scratches caused by normal use.

Damage caused by extreme weather conditions. (hot, cold, etc.)

Damage caused by dirt, sand, and/or water damage.

Damage caused by continuous operation of the gazebo with either known or unknown problems.

Damage caused by direct sunlight.

Damage caused as a result of failure to follow the assembly instructions as defined in this Owner's Manual.

This Limited Warranty applies only to gazebos normally used for personal, family, or household purposes.

This Limited Warranty specifically excludes commercial gazebos.

### Warranty Exclusions

C.A.I. warrants the gazebo from defects in material and workmanship for a period of 90 days from the original date of purchase.

**REMINDER: PLEASE DO NOT FORGET TO REGISTER YOUR NEW PRODUCT AT  
WWW.CALSPAS.COM**

## DELIVERY AND SET-UP

Please make a record of the following. It will be valuable if service or replacement parts are required.

Gazebo Model: \_\_\_\_\_

Gazebo Serial Number: \_\_\_\_\_

Date Purchased: \_\_\_\_\_

Date Installed: \_\_\_\_\_

Gazebo Dealer's Phone Number: \_\_\_\_\_

Gazebo Dealer's Address: \_\_\_\_\_

Most cities and counties require permits for exterior construction and electrical circuits. In addition, some communities have codes requiring residential barriers such as fencing and/or self-closing gates on property to prevent unsupervised access to the property by children under the age of 5. Your dealer can provide information on which permits may be required and how to obtain them prior to the delivery of your equipment.

## PLANNING THE BEST LOCATION FOR YOUR GAZEBO

Here are some of the things that you will need to consider when determining where to locate your new gazebo.

### How Will You Use Your Gazebo?

How you intend to use your gazebo will help you determine where you should position it. For example, will you use your gazebo for recreational purposes? If your gazebo is mainly used for family functions, be sure to leave plenty of room around it for activity. In any case dealing in how it is to be used, you'll probably want to create a specific mood around it.

### Consider Your Privacy

In a cold- weather climate, bare trees won't provide much privacy. Think of your gazebos surroundings during all seasons to determine your best privacy options. Consider the view of your neighbors as well, when you plan the location of your gazebo.

### Provide A View With Your Gazebo

Think about the direction you will be facing when sitting in your gazebo. Do you have a special landscaped area in your yard that you find enjoyable? Perhaps there is an area that catches a soothing breeze during the day and lovely sunset in the evening. Consider these things when you plan your location.

## PREPARING A GOOD FOUNDATION

Your gazebo needs a solid and level foundation. The area that it sits on must be able to support the weight of the gazebo and the occupants who use it. If the foundation is inadequate, it may shift or settle after the gazebo is in place, causing stress that could alter the structures figure and possibly split the wooden joints.

**NOTE:** Damage caused by inadequate or improper foundation support is not covered by the warranty. It is the responsibility of the gazebo owner to provide a proper foundation for the gazebo.

Place the gazebo on an elevated foundation (preferably a 3” concrete slab).

\* If you are installing your gazebo on an elevated wood deck or other structure, it is highly recommended that you consult a structural engineer or contractor to ensure the structure will support the weight.

\* It is strongly recommended that a qualified, licensed contractor prepare the foundation for your gazebo.

## Your Cal Spas Creative Wood Designs Retailer Can Help You With Foundations And More

Your retailer has a wealth of information and experience about how to get the most out of your gazebo. Your gazebo retailer also has a full line of accessories that are engineered to compliment your gazebo.

**NOTE:** It is strongly advised that you have a licensed professional install the foundation for your new gazebo. It is imperative that the foundation is level, as any damage that occurs due to an uneven foundation is not covered by the warranty.

## Size Specifications

<u>Model</u>	<u>Length</u>	<u>Width</u>
Frontier Gazebo	8'	8'
	10'	8'
	12'	8'
Cottage Gazebo	8'	8'
Cabana Gazebo	7'	7'
	7.5'	7.5'
	8'	8'
Northeast Gazebo	7.5'	7.5'
	8'	8'
Lattice Wall Gazebo	7'	7'
	7.5'	7.5'
	8'	8'
	12'	8'
	16'	8'
	10'	10'
	12'	10'
	16'	10'
	12'	12'

<b><u>Model</u></b>	<b><u>Length</u></b>	<b><u>Width</u></b>
Lattice Wall Gazebo (cont.)	12'	12'
	16'	12'
	10' (Octagon)	10'
	12' (Octagon)	12'
Plexi Wall Gazebo	7'	7'
	7.5'	7.5'
	8'	8'
	12'	8'
	16'	8'
	10'	10'
	12'	10'
	12'	12'
	16'	12'
	10' (Octagon)	10'
	12' (Octagon)	12'
	15' (Octagon)	15'
18' (Octagon)	18'	
Luxury Wall Gazebo	7'	7'
	7.5'	7.5'
	8'	8'
	12'	8'
	16'	8'
	10'	10'
	12'	10'
	16'	10'
	12'	12'
	16'	12'
Savannah Wall Gazebo	12'	8'
	10'	10'
	12'	10'
	16'	10'
	12'	12'
	16'	12'
	10' (Octagon)	10'
	12' (Octagon)	12'
15' (Octagon)	15'	
18' (Octagon)	18'	
Timberline Gazebo	12'	8'
	10'	10'
	12'	10'
	12'	12'
	16'	12'

<b><u>Model</u></b>	<b><u>Length</u></b>	<b><u>Width</u></b>
Lighthouse Gazebo	10'	10'
	12'	10'
	12'	12'
	16'	12'
Plantation Gazebo	10'	10'
	12'	10'
	12'	12'
	16'	12'
Chalet Gazebo	12'(Octagon)	12'
	14'(Octagon)	14'
	16'(Octagon)	16'
<b>Victorian Gazebo</b>	<b>12'(Octagon)</b>	<b>12'</b>
	<b>14' (Octagon)</b>	<b>14'</b>
	<b>16' (Octagon)</b>	<b>16'</b>

**NOTE:** The gazebo above that is listed in bold lettering is the gazebo that you purchased.

**NOTE:** For all gazebos, regardless of model, it is recommended that the foundation (concrete slab, railroad ties or pre-cast stepping stones) extend beyond the dimension of the gazebo. For example, if the gazebo you purchased is 12'x12', you will want your foundation to be 12.5'x12.5'. The reason for this is because it will be easier to maintain the area around the gazebo (mowing the lawn, edging, etc.) without damaging or scarring the gazebo. Also, in doing this, you will eliminate any potential problems, foundation-wise, in the future.

**NOTE:** This Owner's Manual applies to the various sizes that are included in the Victorian Gazebo line (12'x12', 14'x14' and 16'x16'). While the sizes will vary from gazebo to gazebo, the assembly instructions will be the same, unless otherwise noted.

## Tools and Materials

Utility Knife	25' Tape Measure
Cordless Drill	100' Extension Cord
1/8" Pilot Hole Drill Bit	1/2" Ratchet and Impact Drill
Electric Drill	9/16" Socket
Phillips-Head Drill Tips	1/2" Carbide Drill Bit (Masonry Bit)
Slotted-Head Drill Tips	Sandpaper (Various Grades)
Redwood Stain	Wood Putty
Gray Wash Stain	Rags

# ASSEMBLY INSTRUCTIONS

The following sections will tell you how to assemble your gazebo. If you have any questions, problems with material and/or parts, please contact your local retailer.

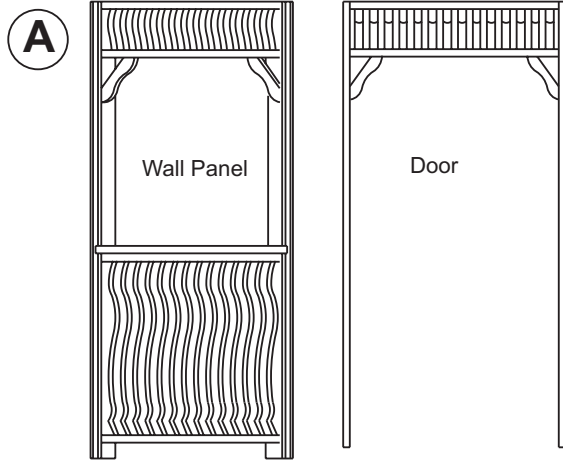

## Wall Panel Assembly

**NOTE:** Check the parts list that came with your gazebo and make sure that all the parts are present. Please follow the written steps in conjunction with the figures that are shown.

1. Stand wall panels up vertically with the flush side of the panel facing inward (fit panels together as shown in **Figure 2A,C**).
2. Drill holes in all 2"x4" boards. Use the wall panels as a template. Each wall panel has been pre-drilled.
3. Insert the provided 5/16"x7" threaded rod and washer into the pre-drilled holes and tighten with the nut (**Figure 2B**).
4. Repeat until wall panel assembly is complete.

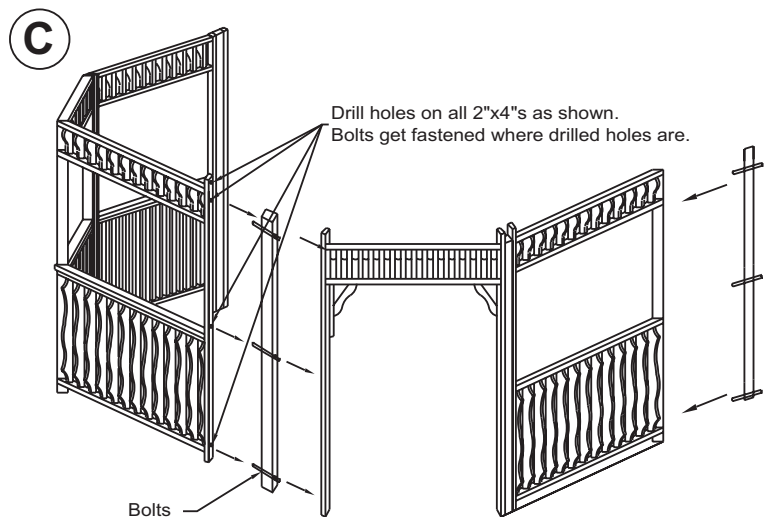
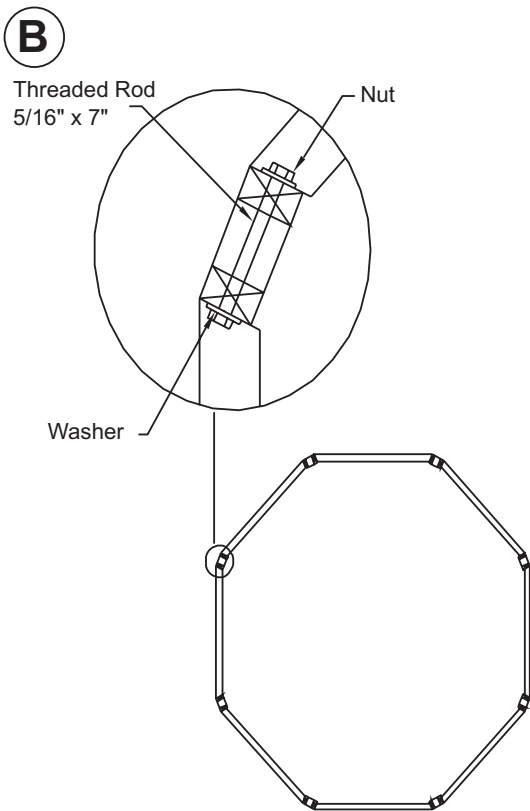

**Figure 2. Wall Panel Assembly**

### COMPOSITION ROOF ASSEMBLY

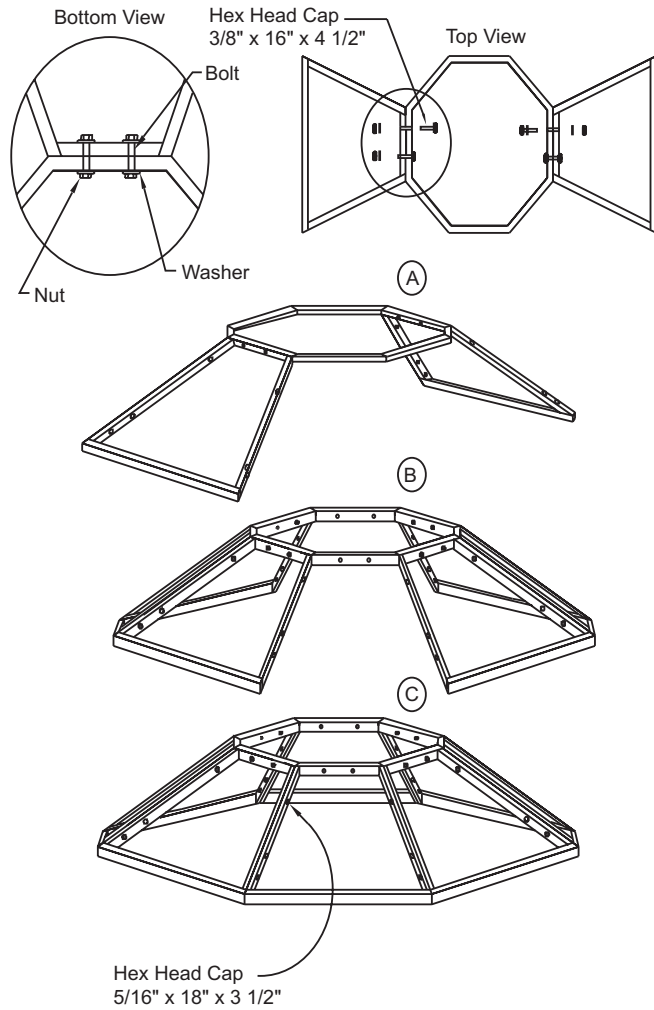

**NOTE:** Check the parts list that came with your gazebo and make sure that all the parts are present. Also, please follow the written steps in conjunction with the figures that are shown.

1. Lay the 8-sided main roof support section flat on the ground (**Figure 3A**).
2. Take one 4-sided roof frame section and place the narrow end against the 8-sided main roof support section (**Figure 3B**).
3. Using the provided hardware, insert two 3/8"x16"x4 1/2" hex-head cap bolts through the pre-drilled holes (**Figure 3C**) and tighten with the washer and nut.
4. Repeat this process until roof frame is complete.

**Figure 3.** Composition Roof Assembly



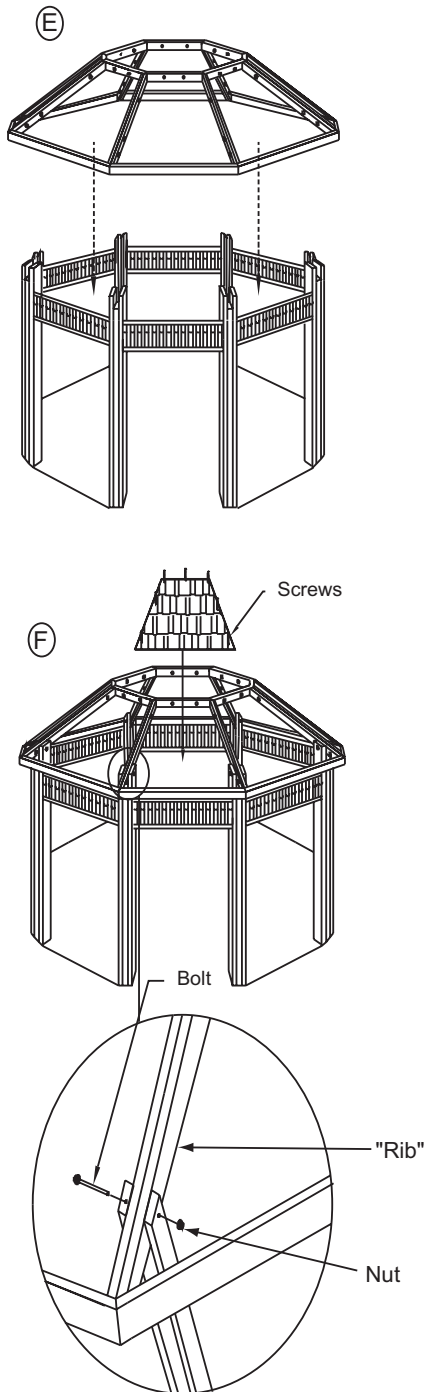

**Figure 3. Composition Roof Assembly**

5. Using the provided hardware, insert two 5/16"x18"x3 1/2" bolts into the pre-drilled holes that are located on the sides of the 4-sided roof frame and tighten with the washer and nut (**Figure 3E**).

6. Repeat until roof frame is complete.

**NOTE:** It is strongly recommended that two people perform the following steps, as the roof assembly is extremely heavy.

7. Having already assembled the wall panels, and now the roof frame, pick up the roof assembly and place it on top of the wall panel assembly.
8. The top of each wall panel support has a slot (8 slots total). Place each "rib" of the roof frame into each one of these slots (**Figure 3F**).
9. Using the provided hardware, insert a 5/16"x18"x3 1/2" bolt into the pre-drilled hole that is located on the slotted end of the wall panel support and the "rib" section of the roof frame.
10. Repeat this process until the roof frame is securely attached to the wall panel assembly.

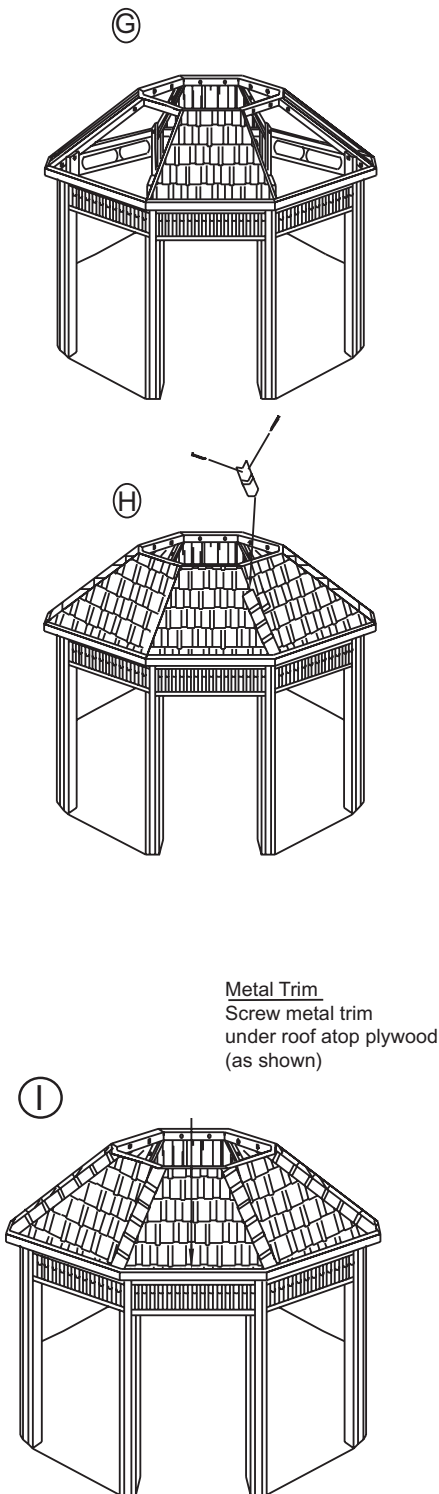

11. Take one 4-sided section of shingled roof and attach it to the corresponding location on top of the roof frame.
12. Attach each individual corner roof shingle. Start at the bottom of the roof and work up to the top, securing each shingle as you go (**Figure 3G**).
13. Repeat this process until shingled roof sections are securely attached to the roof (**Figure 3H**).
14. Using the provided metal trim, slid the non-decorative piece under the shingle layer, but above the plywood layer (**Figure 3I**).
15. Attach the metal trim, using the provided metal screws, by screwing it into the plywood layer (from underneath the roof) (**Figure 3J**).
16. Repeat this process until the metal trim pieces are securely attached to the roof.

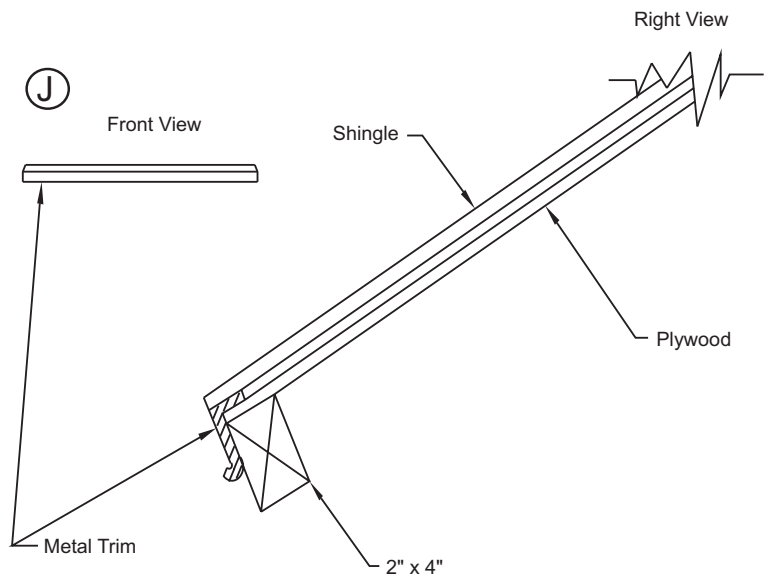

**Figure 3. Composition Roof Assembly**

Top View of gazebo with benches in place.

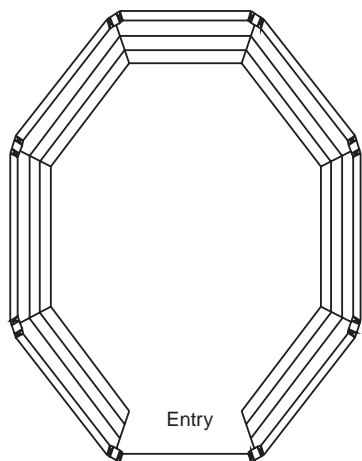

### Bench Assembly

1. After checking to see if all of the parts are present, lay the top piece of the bench flat on the ground (smooth-side down).
2. Screw in each individual bench support (**Figure 4**) with the provided screws.
3. Repeat this process until all of the benches are complete.

Screw bench supports as shown below

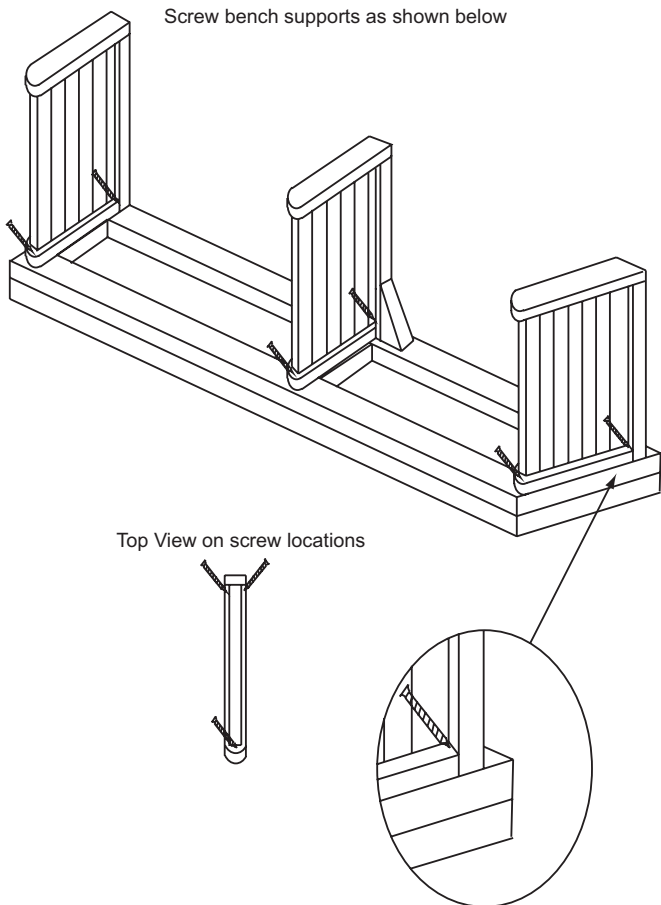

**Figure 4. Bench Assembly**

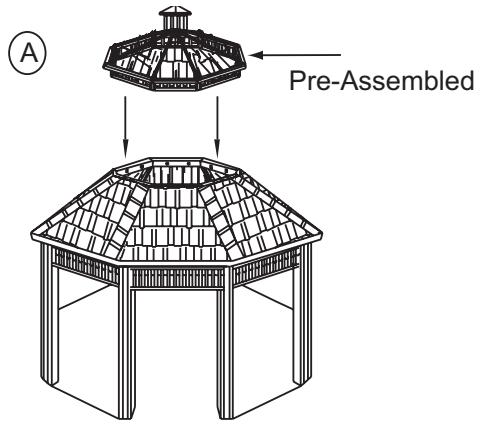

Screw on each shingle (as shown)

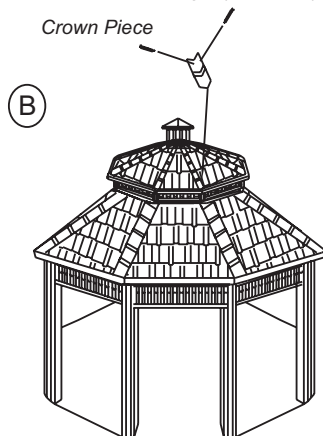

## Final Assembly

**NOTE:** It is strongly recommended that two people perform the following steps, as the copula roof assembly is heavy.

1. Take the assembled copula and place it on top of the gazebo roof (**Figure 6A**).
2. Attach each individual corner copula roof shingle. Start at the bottom of the copula roof and work up to the top, securing each shingle as you go (**Figure 6B**). Repeat this process until all corner shingles are in place.
3. Attach the copula crown piece (**Figure 6**).

## CLEANING AND MAINTENANCE

### Cleaning

Your gazebo was designed with low cleaning and maintenance in mind. We recommend that the gazebo be cleaned at least twice a month (or more, if needed). When cleaning your gazebo, cleaning solvents are not recommended. Using a sponge and water will be fine. For ground-in dirt and grime, please refer to the following section.

### Maintenance

Maintaining your gazebo will be an easy task. We recommend that every six months you should do an inspection of the wood on your gazebo. Take note of any deformities in the wood (i.e. cracking, peeling, dirt, grime, etc.). It is recommended that you spot sand these areas with 120-grit sandpaper. When complete, wipe these areas clean with a damp rag.

When dry, you must apply a coat of stain to the sanded area. Wipe the stained area clean and reapply until the sanded area matches the rest of the gazebo.

**NOTE:** An 8oz. can of stain will be supplied with each gazebo. To replace the can of stain, please contact your local Cal Enclosures dealer.

**NOTE:** On models that have plexi-glass windows, the use of a cheese cloth and warm water should be used. These windows are made of plexi-glass and do not hold up well under the abrasive conditions that many commercial cleaners generate.

## TROUBLESHOOTING PROCEDURES

**Q: Why will the windows on the gazebo not stay open/closed?**

**A:** This is most likely due to the fact that your foundation is not level. Foundations will most likely have a 1/4" pitch for drainage reasons. To rectify this problem, the gazebo must be shimmed on the low side. Using a standard level, shim the low side so that the gazebo is level.

**Q: Why won't the roof panels not sit correctly on the roof frame?**

**A:** Check the top plate on the top center frame and make sure it is level and installed correctly.

**Q: My roof and wall panels are not lining up correctly and there are small gaps in the joint seams. Why is this?**

**A:** The main support post is not "plumb" (meaning vertically level). You must go back and make sure that the main support post is plumb. Also, you must make sure that each of your main support beams is "square" in relation to the main support post (meaning that there is a 90° angle when the main support post and the main support beam intersect).

## **APPENDIX**

The items that will be covered in this section will consist of the following:

Accessories

Part Numbers

Notes

In order for your retailer to expedite your order, for parts and accessories, it is recommended that you have the information that you attained in the Set-Up and Delivery section. Customer Service will want all this information for warranty purposes.

## ACCESSORIES

The following is a list of all the accessories that you can use with your Cal Spa Creative Wood Designs Gazebo. If you wish to order an accessory, feel free to contact your dealer with the desired part name and part number, or visit [www.calspas.com](http://www.calspas.com).

<b>Description</b>	<b>Size</b>	<b>Wood</b>	<b>Part Number</b>	
			<b>Cal Stone</b>	<b>Deluxe Stone</b>
Bar Top	11'	WOOD289	WOOD289CS	WOOD289DS
	80'	WOOD288	WOOD288CS	WOOD288DS
	75'	WOOD287	WOOD287CS	WOOD287DS
Round Corner		WOOD199	WOOD199CS	WOOD199DS
Storage Bench	11'	WOOD905	WOOD905CS	WOOD905DS
	80'	WOOD902	WOOD902CS	WOOD902DS
	75'	WOOD901	WOOD901CS	WOOD901DS
Crescent S/B		WOOD900	WOOD900CS	WOOD900DS
Bar Corbel		WOO270405060		
Bench Leg		WOO27405020		
Bar Stool		WOOD127	WOOD127CS	WOOD127DS
Surround Step	11'	WOOD296		
	80'	WOOD297		
	75'	WOOD298		
Crescent Step		WOOD214		
30' Step		WOOD107		
30" Storage Step w/Box		WOOD133		
5' Step		WOOD109		
5' Step Storage w/Box		WOOD134		
30" Step w/Handrail		WOOD107-2		
Round Planter		WOOD101		
Square Planter		WOOD100		
Crown Planter		WOOD189		
Octagon Planter		WOOD148		
Crescent Planter		WOOD168		
Bench	11'	WOOD923	WOOD923CS	WOOD923DS
	80'	WOOD922	WOOD922CS	WOOD922DS
	75'	WOOD921	WOOD921CS	WOOD921DS
Crescent Bench		WOOD920	WOOD920CS	WOOD920DS
Privacy Panel		WOOD183		
30" Step (3 tier)	30"	WOOD108		
30" Step (3 Tier with Handrail)	30"	WOOD108-2		
Towel/Wine Glass Rack	4'	WOOD113		
Towel/Wine Glass Rack	5'	WOOD113-5		
Wine Glass Hanger		WOOD114		
Towel Tree		WOOD169		
Kidzone Playhouse		KDZ100		

## PARTS LIST

### 12'x12' Octagon Composition Roof

<u>Item Number</u>	<u>Description</u>	<u>Part Number</u>	<u>Quantity</u>
1	48"x93 1/2" Wall Panel	WOO27102589	7
2	48"x93 1/2" Door Panel	WOO27102588	1
3	4"x4"x90"	WOO27211260	8
4	Roof Panel Solid	WOO27216810	8
5	58 1/2"x58 1/2" Top Center	WOO27211481	1
6	59"x49" Roof Frame	WOO27216814	8
7	Pagoda Wall Frame	WOO27215141	1
8	Pagoda Roof Solid	WOO27206347	8
9	Pagoda Roof Frame	WOO27206348	1
10	2"x4"x34" Crown Molding	WOO27213441	8
11	2"x4"x79" Crown Molding	WOO27208260	8
12	2"x6"x45 7/8" M2 22 1/2" Top Rail	WOO27402702	7
13	Philbugle Head 8x5/8"	HAR13200010	60
14	5/16"x18"x3 1/2" Hex Head Cap Screw	HAR13201051	20
15	5/16" USS Flat Washer	HAR13500170	40
16	3/8"x16"x4 1/2" Hex Head Cap Screw	HAR13300150	20
17	1/4" USS Flat Washer	HAR13500040	112
18	Screw 8x2 1/2" SQ. Drywall	HAR13201150	125
19	Screw 8x3" SQ. Drywall	HAR13201140	40
20	3/8" 16 Nut	HAR13400050	20
21	5/16"x7 Screw/Lug Hex	HAR13200481	36
22	5/16" Nut	HAR13201180	92
23	8 oz. Can Of Touch Up Paint/ Stain	CHE07000575	1
24	Warranty and Registration Card	LTR17001970	1
25	Copula	WOO2721515	1
26	4' Bench Top for 12' Octagon-Gazebo	WOO27300197	7
27	System Bench Support Leg	WOO27405020	21
28	2"x4"x6 1/2" Corner Stabilizer	WOO27200600	21
29	12' Victorian Deck	WOO27305872	8
30	Center Octagon Deck	WOO27305662	1

### Solid Roof

31	Roof Panel w/ Shingles 59"x50 1/2"	WOO27216810	8
----	------------------------------------	-------------	---



# NOTES